

Introduced _____
Public Hearing _____
Council Action _____
Executive Action _____
Effective Date _____

County Council of Howard County, Maryland

2017 Legislative Session

Legislative Day No. 10

Bill No. 54-2017

Introduced by: The Chairperson at the request of the County Executive

AN ACT pursuant to Section 612 of the Howard County Charter, approving a multi-year Wholesale Water Agreement between Howard County, Maryland and the Mayor and City Council of Baltimore, a municipal corporation, for the purchase of potable water; authorizing the County Executive to enter into the Agreement and to make changes to the Agreement before executing it, under certain conditions; and generally relating to a multi-year agreement for the purchase of potable water.

Introduced and read first time _____, 2017. Ordered posted and hearing scheduled.

By order _____
Jessica Feldmark, Administrator

Having been posted and notice of time & place of hearing & title of Bill having been published according to Charter, the Bill was read for a second time at a public hearing on _____, 2017.

By order _____
Jessica Feldmark, Administrator

This Bill was read the third time on _____, 2017 and Passed ____, Passed with amendments ____, Failed ____.

By order _____
Jessica Feldmark, Administrator

Sealed with the County Seal and presented to the County Executive for his approval this ____ day of _____, 2017 at ____ a.m./p.m.

By order _____
Jessica Feldmark, Administrator

Approved/Vetoed by the County Executive _____, 2017.

Allan H. Kittleman, County Executive

NOTE: [[text in brackets]] indicates deletions from existing law; TEXT IN SMALL CAPITALS indicates additions to existing law; ~~Strike out~~ indicates material deleted by amendment; Underlining indicates material added by amendment.

1 **WHEREAS**, Baltimore City, a municipal corporation duly and legally created by the
2 General Assembly of the State of Maryland, owns and operates a public water supply,
3 treatment and distribution system built and maintained by Baltimore City to provide potable
4 water (the “Baltimore Water System”); and

5
6 **WHEREAS**, the County also owns and operates a public water distribution system;
7 and

8
9 **WHEREAS**, due to limited groundwater supply and no surface water rights on the
10 two major rivers that border the County, the County’s primary source of drinking water is the
11 Baltimore Water System; and

12
13 **WHEREAS**, pursuant to a 1972 Basic Agreement, of which the County was not a
14 signatory, Baltimore City supplies potable water on a wholesale basis to the County from the
15 Baltimore Water System; and

16
17 **WHEREAS**, Baltimore City is willing to continue selling potable water to the
18 County through the Baltimore Water System and the County wishes to continue to purchase
19 potable water from Baltimore City; and

20
21 **WHEREAS**, it is in the best interest of the County to enter into a mutually satisfactory
22 agreement for a term of 40-years with Baltimore City to continue to purchase potable water
23 at a reasonable rate pursuant to the Wholesale Water Agreement By and Between the Mayor
24 and City Council of Baltimore and Howard County, Maryland, substantially in the form
25 attached as Exhibit 1; and

26
27 **WHEREAS**, the Agreement requires the payment by the County of funds from an
28 appropriation in a later fiscal year and therefore requires the County Council approval as a
29 multi-year agreement pursuant to Section 612 of the Howard County Charter.

30
31 **NOW, THEREFORE,**

1

2 **Section 1. Be It Enacted** by the County Council of Howard County, Maryland, that, in
3 accordance with Section 612 of the Howard County Charter, it approves the Wholesale
4 Water Agreement By and Between the Mayor and City Council of Baltimore and Howard
5 County, Maryland, substantially in the form attached as Attachment 1.

6

7 **Section 2. And Be It Further Enacted** by the County Council of Howard County, Maryland,
8 that the County Executive is authorized to enter into the Wholesale Water Agreement By and
9 Between the Mayor and City Council of Baltimore and Howard County, Maryland in the
10 name of and on behalf of the County.

11

12 **Section 3. And Be It Further Enacted** by the County Council of Howard County, Maryland,
13 that the County Executive, prior to execution and delivery of the Wholesale Water Agreement
14 By and Between the Mayor and City Council of Baltimore and Howard County, Maryland,
15 may make such changes or modifications to the Agreement as he deems appropriate in order
16 to accomplish the purpose of the transaction authorized by this Act, provided that such
17 changes or modifications shall be within the scope of the transaction authorized by this Act;
18 and the execution of the Agreement by the County Executive shall be conclusive evidence of
19 the approval by the County Executive of all changes or modifications to the Agreement, and
20 the Agreement shall thereupon become binding on the County in accordance with its terms.

21

22 **Section 4. And Be It Further Enacted** by the County Council of Howard County, Maryland,
23 that this Act shall become effective immediately upon its enactment.

Wholesale Water Agreement By and Between the
Mayor and City Council of Baltimore and Howard
County, Maryland

Table of Contents

Article One- Definitions	page 2
Article Two- Core System Determination-	page 4
Article Three- Water System Capacity	page 5
Article Four- Monthly Service Charge	page 6
Article Five- Measuring Equipment	page 8
Article Six- Operating Parameters	page 9
Article Seven- Covenants, Representations and Warranties	page 10
Article Eight- Contract Term, Breach & Termination	page 11
Article Nine- Force Majeure	page 13
Article Ten- Dispute Resolution	page 13
Article Eleven- Governing Law	page 14
Article Twelve- Audits, Recordkeeping & Reports	page 14
Article Thirteen- Miscellaneous Provisions	page 15

EXHIBITS

Exhibit A-1	Baltimore City Water System (Zone Map)	page 20
Exhibit A-2	Baltimore City Water System (Hydraulic Schematic)	page 21
Exhibit B-1	Howard County Water Service Area (Zone Map)	page 22
Exhibit B-2	Howard County Water Service Area (Hydraulic Schematic)	page 23
Exhibit C	Annual Statement of O&M Cost Allocation	page 24
Exhibit D	Cost-of-Service Wholesale Rate Model	page 27
Exhibit E	Compliance Documents	page 32
Exhibit F	Emergency Contacts for Water Supply and Water Quality Issues	page 33

WHOLESALE WATER AGREEMENT
BY AND BETWEEN
THE MAYOR AND CITY COUNCIL OF BALTIMORE
AND HOWARD COUNTY, MARYLAND

This WHOLESALE WATER AGREEMENT (“Agreement”) is made and entered into this _____ day of _____, 2017 by and between the MAYOR AND CITY COUNCIL OF BALTIMORE, a municipal corporation duly and legally created by the General Assembly of the State of Maryland, acting by and through its Department of Public Works (the “City”), and HOWARD COUNTY, MARYLAND, a body corporate and politic and a political subdivision of the State of Maryland, (the “County”). The City and the County are sometimes referred to individually as a “Party” and collectively as the “Parties”.

WHEREAS, the City owns and operates a public water supply, treatment and distribution system built and maintained by the City to provide potable water to customers (the “Baltimore Water System” or “System”), which is depicted in Exhibits A-1 and A-2; and

WHEREAS, the County owns and operates a public water distribution system as shown in Exhibits B-1 and B-2; and

WHEREAS, by existing agreements the City supplies potable water on a wholesale basis to the County from the Baltimore Water System; and

WHEREAS, the City is willing to continue selling potable water to the County through the Baltimore Water System; and the County desires to continue purchasing water service from the City; and

WHEREAS, it is deemed to be in the best interest of both the City and the County that the Parties enter into a mutually satisfactory agreement by means of which the County may obtain from the City a supply of potable water at a reasonable rate; and

WHEREAS, it is the purpose of the Parties to continue the operation of the Baltimore Water System and to establish a method for the computation and payment of expenses incurred by the City and the County in connection with the Baltimore Water System; and

WHEREAS, by the execution of this Agreement, neither of the Parties will surrender any of its rights to the ownership and operation of its present water facilities.

NOW THEREFORE, THIS AGREEMENT WITNESSETH, that in consideration of the mutual promises and undertakings contained herein and other good and valuable consideration, the receipt and sufficiency of which is hereby acknowledged, the Parties hereto agree as follows:

ARTICLE ONE

DEFINITIONS

Unless the context shall clearly indicate some other meaning or may otherwise require a different meaning, the terms defined in this Article shall, for all purposes of this Agreement and of any agreement or other instrument amendatory hereof or supplemental hereto, have the meanings herein specified, with the following definitions to be equally applicable to both the singular and plural forms of any terms herein defined, unless otherwise specifically provided herein.

1.1 “Annual Statement for O&M Cost Allocation” means the document showing the computation basis used to derive and allocate the proportionate share of Operation & Maintenance Costs to the County in accordance with the methods of costing as set forth in Exhibit C.

1.2 “Average Daily Demand” means the total volume of water measured at the Billing Meter within a calendar year divided by the number of days in the calendar year, either 365 or 366, provided that for any partial calendar year the exact number of applicable calendar days shall be used, and expressed in units of volume (such as gallons or million gallons) per day.

1.3 “Billing Meter” means a metering device installed at each Interconnection Point, and maintained by the City with readings taken and provided to the City by the County, that shall be the basis for volume measurement and the Volume Charge.

1.4 “CAFR” means the Comprehensive Annual Financial Report of the City.

1.5 “Capital Cost” means the cost of a material addition, expansion, replacement, rehabilitation and/or upgrade to the Core System and does not include any costs associated with assets other than the Core System. Repair costs amounting to less than \$250,000 per incident of repair shall not be included in “Capital Cost” but shall instead be categorized within “Operation and Maintenance Costs”. Upon provision of notice to the County by the City, the base amount shall be adjusted in accordance with any changes in the City’s capitalization policy as contained in the City’s Finance Department’s Administrative Manual. “Capital Cost” shall exclude the amount of any grant from the Federal government, State of Maryland or capital contributions by others than the parties to this Agreement.

1.6 “Contracted Capacity” means that portion of the Baltimore Water System capacity allocated to the County, and jointly verified by the Engineers of the City and County as a reasonable projection of the County’s anticipated needs, as further defined in Section 2.3.

1.7 “Core System” means the assets of the Baltimore Water System that are used and useful to all wholesale customers (for the purposes of this agreement, specifically the County). More specifically, the “Core System” assets include the distribution system storage facilities that control the hydraulic grade in a pressure zone from which a wholesale customer is directly supplied, the pumping station that supplies water to that storage facility, the principal transmission water main that carries the water from the pumping station to the storage facility, and the transmission main from the pump station or storage facility to the wholesale customer interconnection point. The Core

System also includes the corresponding facilities (i.e. storage facility, pumping station and primary feed transmission lines) in lower pressure zones that support the pressure zone from which the wholesale customer supply is directly drawn. The Core System also includes the water treatment and transmission facilities that supply finished potable water to the Core System. For the avoidance of doubt, the Core System excludes the distribution lines that are primarily devoted to serving customers within the geographical limits of Baltimore City.

1.8 “Cost of Service Wholesale Rate Model” hereafter referred to as “the Model” means the methodology for calculation of the Monthly Service Charge detailed in Exhibit D. “The Model” also includes the documentation of the methodology as expressed by means of software instructions and formulae utilizing Microsoft Excel or a successor commercially-available software package.

1.9 “EPA” means the United States Environmental Protection Agency.

1.10 “Fiscal Year” means the twelve-month period beginning July 1 of any calendar year and ending June 30 of the subsequent calendar year, except that the first Fiscal Year shall commence on the date of execution of this Agreement and end at midnight on the next June 30.

1.11 “Fixed Charge” means the charge payable to the City that shall represent the County’s allocation of the Capital Costs, as defined in Section 1.5. The Fixed Charge shall be calculated as described in Section 4.4 and shall be in lieu of upfront contributions, payments, or other fees or charges designed to recoup Capital Costs.

1.12 “Force Majeure” means an occurrence which affects the respective duties and obligations of the Parties hereunder, which duties and obligations shall be suspended while and so long as performance thereof is prevented or impeded, provided that such occurrence is beyond the reasonable control, and not the result of the fault or negligence, of the affected Party, and such Party has been unable to overcome such occurrence with the exercise of due diligence (including the expenditure of reasonable sums). Subject as aforesaid, a Force Majeure occurrence includes civil disturbances, riots, vandalism, vendor delays, fires, floods, hurricanes, tornadoes, epidemics, inclement weather, federal, state, or local governmental action or inaction, acts of war, acts of terrorism, acts of God, or any other cause which is beyond the reasonable control of the party from whom the performance was due.

1.13 “Interconnection Point” or “Interconnection Points” means the service point or points at which the County’s water system connects with the Baltimore Water System.

1.14 “MDE” means the Maryland Department of the Environment.

1.15 “Maximum Day Flow” as provided in Section 2.3 means the largest volume of water consumed during a twenty-four (24) hour period within the Fiscal Year in question and expressed in units of volume (such as gallons or million gallons) per day.

1.16 “Maximum Daily Demand” means the Maximum Day Flow that the City is obligated to provide to the County as provided in Section 2.3.

- 1.17 “MGD” means millions of gallons per day.
- 1.18 “Monthly Service Charge” means the sum of the County’s Fixed Charge and Volume Charge.
- 1.19 “Operation and Maintenance Costs” (hereafter “O&M Costs”) means that portion of the City’s potable water operating budget, exclusive of Capital Costs, which represents all costs of labor, equipment, materials, supplies, services, chemicals and power and all other things and expenses necessary to operate and maintain the transmission, transportation and treatment facilities and the accumulation of operational reserves related to payment of such costs so that the facilities will supply the County its allocated capacity.
- 1.20 “Penalty Charge” means an all-inclusive rate calculated by applying the volumetric rate applicable to the City’s retail customers, set by the City’s Board of Estimates and in place at the time of the County’s exceedance, to the volumetric units that exceed the Contracted Capacity, as further provided in Section 3.3.
- 1.21 “Rate Base” means the depreciated book value of those assets in the Core System.
- 1.22 “Rate of Return” means the percentage factor as defined in Section 4.5.
- 1.23 “Return” means that portion of the “Fixed Charge” that is defined in Section 4.5 and comprised of two (2) components, a Return on debt and a Return on equity. Return on debt shall be the actual interest charges incurred on outstanding Core System debt. The Return on equity shall be calculated as rate of return times the City’s equity in the Core System (i.e., the Core System assets unencumbered by debt), with the rate of return on equity being calculated as the embedded interest rate on outstanding Core System debt plus a 6% equity premium (“Rate of Return”).
- 1.24 “Volume Charge” means the monthly charge payable to the City for the County’s proportionate share of water supply, treatment and transmission O&M Costs of the Core System. The Volume Charge shall be calculated as described in Section 4.3.
- 1.25 “Volumetric Rate” means O&M Costs of the Core System divided by annual metered flow of treated water and shall be determined retrospectively from the County’s share of O&M Costs for the Core System facilities for the Fiscal Year prior to the one in question.
- 1.26 “Water Enterprise Fund” means the water utility enterprise as established under Article VI, §18 of the Baltimore City Charter.

ARTICLE TWO

CORE SYSTEM DETERMINATION

2.1 Source of Supply and Water Filtration

All sources of supply and water filtration assets are part of the Core System, as defined in Section 1.7, as long as they are used and useful to all customers.

2.2 Water Storage, Pumping and Transmission Mains

Water pumping, storage and transmission assets shall be included in the Core System, as defined in Section 1.7, as long as they are determined to be used and useful to all wholesale system customers.

2.3 Pledge to Reserve Core System Capacity

In consideration of the County's agreement to pay the Monthly Service Charge and of the other terms, warranties, representations and agreements herein contained, the City agrees to design, construct, operate and maintain the facilities required to serve the County's contracted water needs; and further agrees to reserve and maintain for the County a Core System capacity allocation of 38.50 million gallons per day (MGD) average day flow and 57.75 MGD Maximum Day Flow, provided that the City is obligated to provide the County's water demand on any given day up to 57.75 million gallons ("Maximum Daily Demand"), and the County is obligated to limit its Average Daily Demand in any Fiscal Year to no more than 38.50 MGD. The aforesaid capacity allocation is hereinafter referred to as "Contracted Capacity".

ARTICLE THREE

WATER SYSTEM CAPACITY

3.1 Water Capacity Available

The City shall provide water transmission and treatment capacity to the County at the Contracted Capacity, as defined in Section 2.3, except as provided in Sections 3.4 and 3.5 herein. Failure by the City to comply with this obligation shall constitute a Material Breach of this Agreement.

3.2 Additional Water Capacity

The County shall be required to enter into negotiations with the City for additional water capacity should the County exceed its Contracted Capacity except as allowed under Section 3.3. The County may negotiate for additional capacity at any time should excess capacity be available.

3.3 Abnormally High Water Usage

Water consumption that exceeds the Maximum Daily Demand due to unforeseen circumstances will be allowed up to two (2) such events per Fiscal Year without cause for renegotiation of the Contracted Capacity and resulting costs. An event shall be no longer than twenty-four (24) hours in duration. The County shall document the cause of such events to the City within one month of occurrence and include a plan for corrective action. Any exceedance of the Contracted Capacity beyond the aforesaid limits of two (2) events per year, or twenty-four (24) hours for any one event, may result in a Penalty Charge for the amount of the exceedance and shall require immediate renegotiation of the Contracted Capacity.

3.4 Emergency or Maintenance Shutoff

The City undertakes to use reasonable care and diligence to provide uninterrupted service as provided herein, but reserves the right at any time temporarily to interrupt service for emergency and

maintenance purposes. The City shall give notice to the County not less than forty-eight (48) hours in advance of any such service interruption, except that in emergencies, it shall give notice that is reasonable under the particular circumstances. The City shall restore, expeditiously, the Baltimore Water System to its pre-emergency capability to supply water to the County.

3.5 Water Restrictions

In the event of a water supply emergency, the County will work in conjunction with the City to promote water usage conservation, and, if determined to be necessary by the City, impose appropriate water usage restrictions or conservation measures that are consistent and proportionate within the two jurisdictions.

ARTICLE FOUR

MONTHLY SERVICE CHARGE

4.1 General

City billings to the County shall be in the form of a Monthly Service Charge which shall consist of a fixed component and a volume component.

4.2 Setting the Monthly Service Charge

Components of the Monthly Service Charge shall be set prospectively prior to the beginning of the Fiscal Year. The Volume Charge will be calculated to recover O&M Costs and the Fixed Charge will be calculated to recover Capital Costs in the form of depreciation and Return.

4.3 Volume Charge

The Volume Charge will be calculated based on the County's monthly metered flow through the Interconnection Points, multiplied by the Volumetric Rate. Detail of the calculated Volume Charge is shown in Exhibit D.

4.4 Fixed Charge

The Fixed Charge will consist of the County's share of Capital Costs using a utility approach to cost allocation and shall include a Return, as specified in Section 4.5. The Fixed Charge shall be set prospectively based upon Contracted Capacity as defined in Sections 1.6 and 2.3. The Fixed Charge shall be divided into twelve equal monthly payments and assessed as the fixed component of the Monthly Service Charge. Detail of the Fixed Charge is shown in Exhibit D.

4.5 Return

The City shall be due a fair and equitable return ("Return") on its investment in the Core System assets, provided however that the City may earn a Return only on the Rate Base. The "Return" shall be split into two (2) components, a Return on debt and a Return on equity. Return on debt shall be the actual interest charges incurred on outstanding Core System debt. The Return on equity shall be calculated as rate of return times the City's equity in the Core System (i.e., the Core System assets unencumbered by debt), with the rate of return on equity being calculated as the embedded interest

rate on outstanding Core System debt plus a 6% equity premium (“Rate of Return”). Detail of the Return calculation is shown in Exhibit D.

4.6 Review of Audited Annual Financial Reports and Supporting Documents

Prior to each wholesale rate adjustment, the City shall provide such reports and documents as are generated in accordance with the requirements of Article VI §18 of the Baltimore City Charter and such reports and documents generated in the ordinary course by the City for the completed Fiscal Year for the Water Enterprise Fund and shall furnish a copy thereof to the County for review. The City shall also furnish a copy of the Annual Statement for O&M Cost Allocation to the County for its review and concurrence. The reports and documents furnished by the City pursuant to this paragraph 4.6, the approved Annual Statement for O&M Cost Allocation, and actual billed system flows for the same Fiscal Year shall serve as input for the calculation of cost-to-serve rates for the upcoming Fiscal Year as detailed in Exhibit D. Wholesale charges are to be updated by the City prior to any wholesale rate adjustment and provided to the County for review. The City represents and warrants that such reports will be compliant with the City’s obligations under State law and by bond covenant to utilize generally accepted accounting principles, which are defined by the Governmental Accounting Standards Board.

4.7 Annual True-Up of Costs

Upon completion of the CAFR, the City will prepare a true-up for the Fiscal Year based on actual capital and operating costs. The result of the true-up shall be an addition to, or a reduction in the prospective Monthly Service Charge set for the upcoming Fiscal Year.

4.8 Billing and Payment Dates

Monthly readings from the Billing Meters will be provided by the County to the City on or before the 10th day of each month. Either party may read the meters locally or remotely at any time. Monthly billings shall be sent to the County by the City on or before the 20th day of each month showing the amount due for the previous month.

Invoices in the proper form as provided below and approved by the County shall be paid by the County within thirty (30) days of receipt by the County. Late payments may be subject to a penalty of not more than one percent (1%).

The City’s invoices shall reflect the City’s:

- Name
- Address
- Federal tax identification number
- Description of services performed

The proper form of County invoices requires that the information above be included on all invoices.

ARTICLE FIVE

MEASURING EQUIPMENT

5.1 General

The City shall own, operate and maintain one or more appropriate Billing Meter(s) to measure the water flow at each Interconnection Point. The City will bear the cost of operating and maintaining the metering facilities, and will recover the costs through the Monthly Service Charges as herein provided. These meters may be equipped with technology to provide remote readings to both the City and the County. The party that procures the meter must provide the other party with documentation from meter manufacture, meter specification and meter curves, validated to the specific Billing Meter.

5.2 City to Supply Official Record

For the purpose of this Agreement, the official record of readings of the Billing Meter or Meters shall be the journal or computer record/website or other record book of the City in its office in which the records of its employees or agents who receive and document the County's readings are or may be transcribed. Upon written request of the County, the City will give the County a copy of such journal or record book or permit the County to have access thereto in the office of the City during regular business hours. The County shall have the right to audit the records and request reconciliation with the County's records in order to correct inaccuracies in the City's records.

5.3 Meter Accuracy

The City shall engage at its cost an independent, third party water meter testing organization or personnel acceptable to the County ("Approved Meter Tester"), which acceptance shall not be unreasonably withheld, to test the Billing Meters at least every six (6) months. Testing shall be performed in accordance with American Water Works Association (AWWA Manual M6: Water Meters Selection, Installation, Testing & Maintenance) and the applicable AWWA water meter standards, as may be revised from time to time. At least one (1) month in advance of the scheduled test, the City will notify the County of the organization or personnel performing the test and the testing procedures to be followed for the County's concurrence, which shall not be unreasonably withheld. The City will notify the County at least forty-eight (48) hours in advance of the scheduled test to confirm the date and time of the test.

In addition to the aforesaid regularly scheduled testing, upon the request of either party based upon reasonable belief that the Billing Meter is not registering accurately, the City shall schedule a certification test of a particular Billing Meter or Billing Meters by an Approved Meter Tester and shall give the County such advance notification thereof as is reasonable under the circumstances. The costs for non-regularly scheduled meter test requests shall be borne by the party that requests the test.

Representatives from the City and/or County may witness each test. The City must furnish the findings to the County within seven (7) days of the test or receipt by the City of the results, whichever is earlier. The acceptable range of accuracy is -3% to +3% of full scale.

Calibration must be performed in a timely manner after detecting that the meter is registering outside the acceptable range of accuracy. Any calibration of the meters and instrumentation will be mutually agreed upon, and may be witnessed by both parties.

5.4 Cost of Metering

The City will bear the costs of providing, operating and maintaining the metering facilities, and will recover these costs through the Monthly Service Charges as herein provided.

ARTICLE SIX

OPERATING PARAMETERS

6.1 Water Quality

The City shall furnish and sell to the County treated water of potable quality meeting at each Interconnection Point all legally enforceable drinking water standards set by federal, state, and local laws, regulations, orders and requirements for water quality (“Applicable Law”), as modified by the Administrative Order for Compliance on Consent, Docket No. SDWA-03-2010-123-DS (including the compliance schedule attached thereto as Attachment 1), and as further modified by letter dated May 31, 2015 from the United States Environmental Protection Agency Region III to Baltimore Department of Public Works, both documents being attached as Exhibit E hereto (“Compliance Documents”). The City shall provide immediate notice to the County of any failure to comply with Applicable Law and/or the Compliance Documents as provided in Section 13.3. Failure of the City to comply with the aforesaid obligations shall constitute a Material Breach.

6.2 Water Pressure

The water delivered by the City to the County shall approximate the normal operating pressure of the City’s pressure in the pressure zone from which the water is supplied to the County’s water system at each Interconnection Point.

6.3 Point of Delivery

The water delivered by the City to the County shall be delivered to each Interconnection Point.

6.4 Testing

The City shall conduct all water quality testing in accordance with Applicable Law. At the County’s written request, the City shall provide the County with copies of such water quality testing.

6.5 Liability

The City assumes all responsibility for ensuring that the water at the Interconnection Points is compliant with Applicable Law as modified by the Compliance Documents. To the extent of the provisions of the Maryland Local Government Torts Act, Section 5-301 et seq. of the Courts and Judicial Proceedings Article, Maryland Annotated Code and subject to the appropriation of funds,

the City shall defend, hold harmless and indemnify the County for any and all third party claims relating to the water supplied to the County at any Interconnection Point which does not comply with Applicable Law as modified by the Compliance Documents. Failure of the City to comply with the aforesaid obligation shall constitute a Material Breach of this Agreement.

As a condition of indemnification, the County agrees to notify the City of any suits, claims or potential claims within ten (10) business days after the County's own notice of such suits, claims or potential claims. The foregoing indemnification is not to be deemed as a waiver of any immunity that may exist in any action against the City for its officers, agents, volunteers and employees.

ARTICLE SEVEN

COVENANTS, REPRESENTATIONS AND WARRANTIES

7.1 Authority of the City

The City represents and warrants that it is duly organized as a municipal corporation fully chartered in the State of Maryland and that it has all power and authority required to enter into this Agreement and perform its obligations hereunder and to make the representations and warranties contained herein.

7.2 Authority of the County

The County represents and warrants that it is a body corporate and politic and a political subdivision of the State of Maryland and that it has all power and authority required to enter into this Agreement and to perform its obligations hereunder and to make the representations and warranties contained herein.

7.3 Approval and Permits

The City covenants that it shall possess all federal, state and local government regulatory approvals and permits, and all licenses and other rights necessary to perform its obligations under this Agreement, at the time those obligations are being performed.

7.4 Regulatory Compliance

The City represents and warrants that the Core System facilities, now and in the future, will be in compliance with all Applicable Law as modified by the Compliance Documents including but not limited to applicable regulatory standards of EPA, the Maryland Department of the Environment, and other federal and State agencies having regulatory authority over drinking water systems. The City's failure to comply with this obligation shall constitute a Material Breach of this Agreement.

7.5 Operation and Maintenance

The City, through its staff, or others employed by the City, covenants to use its best efforts to fulfill all of the operation and maintenance requirements of the Baltimore Water System unless prevented therefrom by Force Majeure.

7.6 Preservation, Maintenance, and Operation of Water Distribution and Transmission System

Each Party represents that it presently owns a water distribution and transmission system providing water service to its users. Each Party covenants to use its best efforts to maintain its system in good repair and working condition, unless prevented therefrom by Force Majeure.

ARTICLE EIGHT

CONTRACT TERM, BREACH AND TERMINATION

8.1 Term of Agreement

This Agreement shall have an initial term of forty (40) years from the date of execution (the “Initial Term”). If neither Party provides notice of intention to terminate (in accordance with Section 8.4) and except in the case of early termination for breach as provided in Sections 8.2 and 8.5, the Agreement will be deemed to extend for one additional forty-year term (“Renewal Term”) on the same terms and conditions, with the exception of the automatic extension provision.

8.2 Breach, Notice and Cure of Breach.

Except as provided in Section 8.5, in the event of a breach, default or failure to perform a duty under this Agreement, the non-breaching Party may send a written notice of such default to the breaching Party. The notice must include a reasonable description of the breach. If the breaching Party fails to cure the breach, default or failure within thirty (30) days of that notice, then the non-breaching Party may give the breaching Party a second notice of its failure to cure the breach. Failure to cure the breach within ten (10) days after the second notice, or a second breach of the same provision of this Agreement, after cure of the first breach, shall constitute a “repeated breach”, and may result in termination of this Agreement as provided in Section 8.5 and subject to the provisions of Section 8.5.

8.3 Notice and Cure for Breach of Water Use Restrictions and Conservation.

If the County fails to comply with any water use restrictions or conservation measures set by the City pursuant to Section 3.5, then the Section 8.2 notice provisions do not apply and the City’s Director of Public Works, in his sole discretion may, in writing, set such time in which the County shall cure the breach.

8.4 Termination of the Agreement Without Cause

The Parties shall have the right to terminate this Agreement without cause during the term of the Agreement, as provided hereunder in this Section 8.4.

8.4.1 Termination by the City

In order for the City to terminate this Agreement pursuant to this Section 8.4, the City shall give at least ten (10) years’ prior written notice to the County, provided however that no termination of this Agreement by the City pursuant to this Section 8.4 shall take effect before the end of the Initial Term.

8.4.2 Termination by the County

In order for the County to terminate this Agreement pursuant to this Section 8.4, the County shall give at least five (5) years' prior written notice to the City. The County shall have the right to terminate this Agreement at any time during the Initial or Renewal Term provided that it gives the City the requisite five (5) year notice as aforesaid.

8.5 Early Termination for Material Breach

Notwithstanding anything in this Agreement to the contrary, any Material Breach, as defined below, by either Party shall be cause for early termination of this Agreement by the non-breaching Party. The notice provisions in this Section 8.5 shall apply in lieu of the Section 8.2 notice provisions to a breach classified as a Material Breach. A "Material Breach" is defined as any breach by the City in the performance of any of its duties or obligations under Sections 3.1, 6.1, 6.5 and 7.4, or any repeated breach (as defined in Section 8.2) by the City of any of the other provisions of this Agreement within any thirty-six (36) month period; or any repeated breach (as defined in Section 8.2) by the County of its payment obligations pursuant to Section 4.9 within any six (6) month period. Upon such Material Breach by the City of Sections 3.1, 6.1, 6.5 or 7.4, the County may notify the City, in writing, of the County's intention to terminate this Agreement if the City fails to cure such breach within such time period set by the County in its written notice. The notice must include a reasonable description of the Material Breach. The County shall notify the City in writing upon acceptance of the cure of any Material Breach. As for a Material Breach by the County, the County shall have fifteen (15) days from written notification by the City to cure any Material Breach. If the County does not cure the Material Breach within said fifteen (15) days, the City shall have the right to terminate the Agreement upon five (5) additional days' written notice to the County, if the Material Breach has not been cured by the County.

Because failure to comply with this Section 8.5 cannot be adequately compensated in monetary damages alone, the Parties shall have available to them the equitable remedy of specific performance if applicable in addition to any other remedy as may be provided by law.

8.6 Effect of Termination

Upon expiration or termination of this Agreement any obligations that, by their sense and context, are intended to survive expiration or termination of this Agreement, shall survive the expiration or termination of this Agreement for any reason. If this Agreement is not renewed before it expires, and the Parties are negotiating in good faith regarding the provisions of a new agreement, then the Parties may mutually reinstate the Agreement and extend the date for termination, in writing that refers to this Section and is signed by both Parties.

8.7 No Waiver by the City

Any failure by the City to terminate this Agreement, or the acceptance by the City of any benefits under this Agreement, for any period of time after a material breach, default or failure by the County shall not be determined to be a waiver by the City of any rights to terminate this Agreement for any subsequent material breach, default or failure.

8.8 No Waiver by the County

Any failure by the County to terminate this Agreement, or the acceptance by the County of any benefits under this Agreement, for any period of time after a material breach, default or failure by the City shall not be determined to be a waiver by the County of any rights to terminate this Agreement for any subsequent material breach, default or failure.

ARTICLE NINE

FORCE MAJEURE

In case any Party by reason of Force Majeure shall be rendered unable wholly or in part to carry out its obligations under this Agreement, then if such Party shall give notice and full particulars of such Force Majeure in writing to the other Party within twenty-four (24) hours of the existence of such Force Majeure, except for water quality, or water supply issues, for which the notice shall be provided to the other Party as set forth in Section 13.3. The obligation of the Party giving such notice so far as it is affected by such Force Majeure shall be suspended during the continuance of the inability then claimed, but for no longer period, and any such Party shall be required to resume performance of its obligations under this Agreement upon the termination of the aforementioned Force Majeure; provided, however, the Party unable to perform shall use its best efforts and act in good faith to avoid or overcome the impediment.

ARTICLE TEN

DISPUTE RESOLUTION

10.1 Purpose

The Dispute Resolution process will provide an orderly mechanism to address disagreements and disputes related to this Agreement. Disputes could relate to monthly service fee calculations; true-up calculations; billing, flow measurement; and other matters of common interest to the Parties.

10.2 Payments Required

If the County chooses to dispute all or any part of any billing or payment arising under terms of this Agreement, the County shall nevertheless pay the undisputed amount, or pay the County's calculation of the amount the County claims is owed, of any such billing or payment when due. The County shall also include with such payment or if the whole amount is disputed the County shall send written notification to the City that there is a dispute of the billing or payment amount, the grounds for the dispute, and the amount in dispute.

10.3 Resolution Process

Level 1 - Resolution by the City and the County

Any dispute regarding this Agreement shall in the first instance be the subject of informal negotiations between the Parties. The Parties shall meet to resolve a dispute within ten (10) days of

the receipt of written notification of a dispute including but not limited to any factual data, analysis, or opinion supporting the Party's position and any supporting documentation relied upon by the Party.

Level 2 – Non- Binding Mediation

In the event that Level 1 efforts prove unsuccessful, or if the governing bodies of the Parties fail to ratify the resolution reached, the Parties may agree to refer any unresolved disputes to non-binding mediation before a mediator agreed upon by the Parties. The election of non-binding mediation is without waiver of any rights either Party may have pursuant to this Agreement, at law or in equity (to the extent applicable to either party as a municipality) which rights are all expressly reserved by the Parties. The Parties agree to cooperate in the selection of a mediator and agree to retain only a highly qualified mediator with experience mediating complex municipal issues. In the event that the Parties cannot agree on a mediator then these Level 2 provisions shall become null and void.

ARTICLE ELEVEN

GOVERNING LAW

This Agreement shall be governed by and construed in accordance with the laws of the State of Maryland, exclusive of its conflicts of laws rules. The Parties agree that any action at law or, to the extent applicable to either Party as a municipality, in equity arising out of or relating to this Agreement shall be filed and adjudicated only in the federal or state courts located in Baltimore City or Howard County, Maryland, and consent to the exclusive jurisdiction and venue of such courts over any suit, action or proceeding arising out of this Agreement.

ARTICLE TWELVE

AUDITS, RECORD KEEPING, AND REPORTS

12.1 Inspection of Records and Reports.

The records, audits and reports of the City shall be made available for inspection to any duly authorized representative of the County at reasonable times, during normal office hours, at the City offices.

12.2 County Flow Projections

The County shall, within ninety (90) days after the close of each Fiscal Year, provide the City with water flow projections. These projections shall be provided for each point of delivery and include estimates for the next four (4) Fiscal Years. Both Parties recognize that the actual capacity utilized may vary from the estimates provided and these figures are provided for planning purposes only, subject, however, to Section 2.3.

ARTICLE THIRTEEN

MISCELLANEOUS PROVISIONS

13.1 Regulatory Bodies

The Parties through this Agreement seek to exercise and maintain all sovereign rights granted to them under and through the Constitution and laws of the State of Maryland. This Agreement shall be subject to all valid rules, regulations, and laws applicable hereto passed or promulgated by the United States of America, the State of Maryland, or any governmental body or agency having lawful jurisdiction, or any authorized representative or agency of any of them; provided, however, that this clause shall not be construed as waiving the right of any Party to challenge the validity of such rule, regulation, or law on any basis, including the impairment of this Agreement.

13.2 Change of Law

The terms and conditions of this Agreement and mutual covenants made between the Parties are based upon existing law as of the date of this Agreement. All terms and conditions contained herein are intended to be absolute conditions hereof and are agreed to by the Parties. A change of law or regulation occurring after the date of execution of this Agreement which occasions a financial impact upon the City, changing the cost of operation and maintenance, or affecting expenditures or capital expense shall be justification for an adjustment in the Monthly Service Charge commensurate with the cost impact. If such adjustments are made, written notice shall be given to the County setting forth the reasons, calculations of the amount and proposed effective date of the adjustment for approval as described in Article 4.

13.3 Notices and Evidence of Actions

All notices or communications provided for herein shall be in writing and shall be delivered (i) in person or (ii) by United States Mail, by certified or registered mail, return receipt requested, postage prepaid, or (iii) overnight by Federal Express or another national courier service, or (iv) by telefax or other means of immediate electronic communication. Notices or communications delivered or mailed to any Party shall be addressed to the principal office of such Party as provided below and, if sent by telefax or other means of immediate electronic communication, to the email addresses listed in Exhibit F.

Notices shall be deemed delivered to the addressee (i) when received and signed for at the address for notice specified below when hand delivered, if such party's receipt is acknowledged in writing; (ii) five (5) business days after deposit in the mail when sent by United States Mail; (iii) on the business day after being sent when sent by overnight delivery service (Saturdays, Sundays and legal holidays excluded); and (iv) on the date sent by telefax or other means of immediate electronic communication (if sent during normal business hours or the next business day if sent at any other time)..

Additionally, all notices regarding water quality and/or water supply issues including but not limited to the City's failure to comply with its obligations in Sections 6.1 and 7.4 hereof shall be delivered to the e-mail address and/or emergency telephone number listed in Exhibit F of the other Party, immediately for any Tier I noncompliance as defined in 40 C.F.R. § 141.202; within 24 hours for

any Tier II noncompliance as defined in 40 C.F.R. § 141.203; and within 30 days for any Tier III noncompliance as defined in 40 C.F.R. § 141.204 after the Party with the obligation to notify learns of the issue.

Either Party may unilaterally change its address/addressee information by providing written notice to the other Party in accordance with this Section 13.3.

For the City of Baltimore:
Baltimore City Department of Public Works
200 Holliday Street, 6th Floor
Baltimore, Maryland 21202

ATTN: Director of Public Works

For Howard County:
Howard County Department of Public Works
3430 Court House Drive
Ellicott City, Maryland 21043

ATTN: Director

13.4 Severability

Should any part of this Agreement, for any reason, be declared invalid or void, such decision shall not affect the remaining portions which shall remain in full force and effect as if this Agreement had been executed with the invalid portion eliminated.

13.5 Non-Assignability

Except to the extent herein provided, no Party shall assign or transfer this Agreement or any rights or interests herein without the written consent of the other Party. The right to receive all payments which are required to be made by the County to the City in accordance with the provisions of this Agreement may be assigned by the City to any trustee as provided in a bond resolution to secure the payment of the principal and premium, if any, and interest on any bonds as those amounts come due, subject to the application of those payments as may be provided in the bond resolution. The County will, upon notice of assignment to any such trustee, make all payments directly to such trustee. The rights of the City to enforce the provisions of this Agreement may be assigned to such trustee and, in such event, the trustee will have the right to enforce this Agreement at law or (to the extent applicable) in equity with or without the further consent or participation of the City. The City may also retain the right to enforce this Agreement.

13.6 Execution in Counterparts

This Agreement may be executed in several counterparts, each of which shall be deemed an original, and all of which shall constitute but one and the same instrument.

13.7 Modification and Amendment

No change, amendment or modification to this Agreement shall be made which will affect adversely the prompt payment when due of the Monthly Service Charge required to be paid by the County under the terms of this Agreement and no such change, modification or amendment shall be effected which would cause a violation of any provisions authorized and issued under a bond resolution or any bonds issued to refund any of the bonds. No change, amendment or modification to this Agreement shall be effective unless done in writing and signed by both Parties.

13.8 Exhibits

All exhibits referenced in this Agreement are incorporated herein by reference as integral parts of this Agreement.

THE REMAINDER OF THIS PAGE PURPOSEFULLY LEFT BLANK

IN WITNESS WHEREOF the parties hereto acting by and through their duly authorized officers, pursuant to appropriate resolutions duly and properly adopted by each have caused this Agreement between the parties to be executed and the official seals of each properly affixed as of the day and year first above written.

ATTES T:

**MAYOR AND CITY COUNCIL OF
BALTIMORE**

Custodian of the City Seal

By: _____
CATHERINE E. PUGH
MAYOR

APPROVED:

Rudolph S. Chow, P.E.
Director of Public Works

**APPROVED AS TO FORM AND
LEGAL SUFFICIENCY**

APPROVED BY THE BOARD OF ESTIMATES

W. Michael Mullen
Chief Solicitor

Clerk

Date

WITNESS/ATTEST:

HOWARD COUNTY, MARYLAND,
a body corporate and politic:

Lonnie R. Robbins
Chief Administrative Officer

Allan H. Kittleman
County Executive

APPROVED:

James M. Irvin, Director
Department of Public Works

APPROVED AS TO SUFFICIENCY OF FUNDS this ____ day of _____, 2017:

Stanley Milesky, Director
Department of Finance

APPROVED AS TO FORM AND LEGAL SUFFICIENCY this ____ day of _____, 2017:

Gary W. Kuc
County Solicitor

Reviewing Attorney:

Morenike Euba Oyenusi, Sr. Assistant County Solicitor

EXHIBIT A-1 – Baltimore Water System (Zone Map)

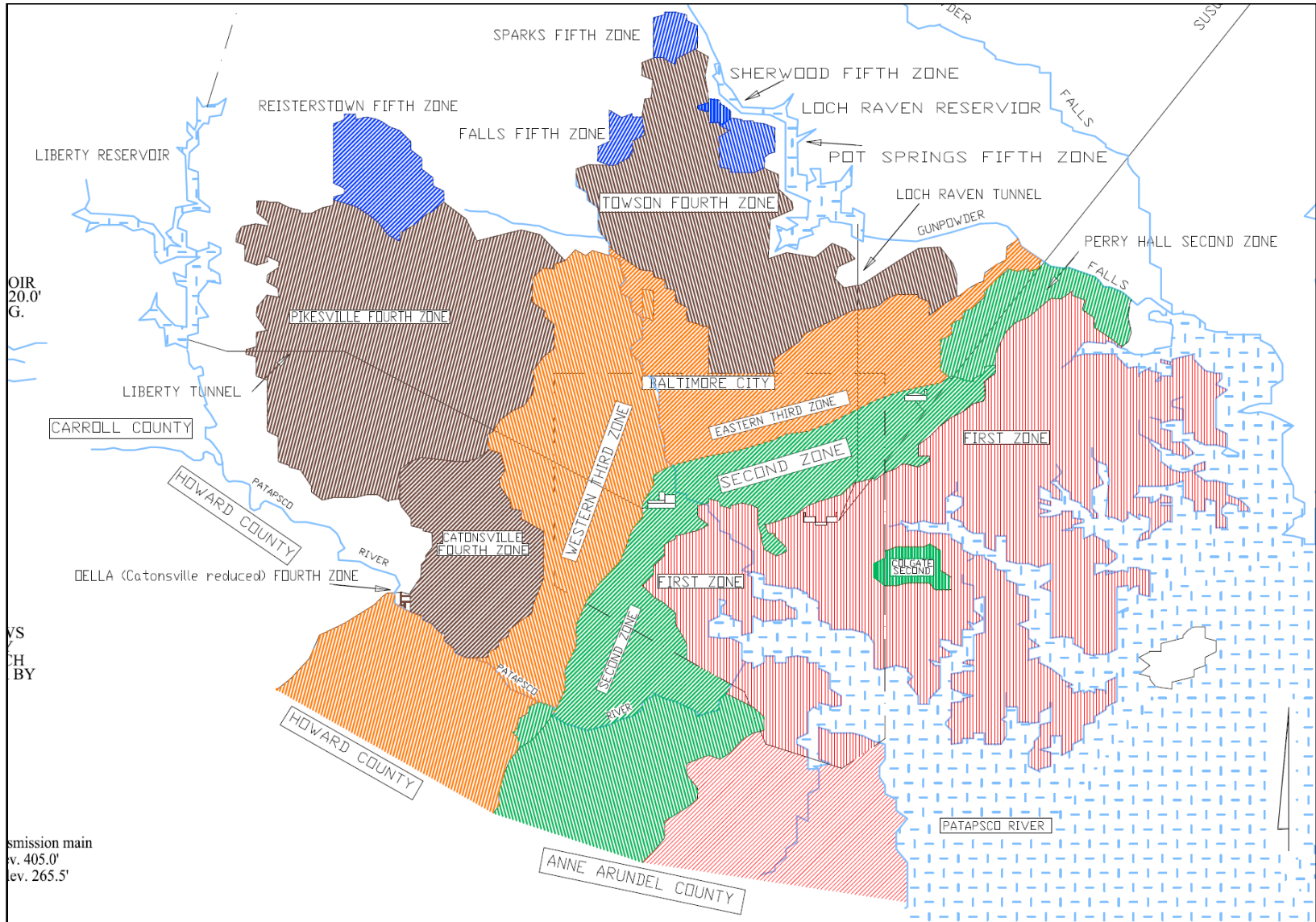

EXHIBIT A-2 – Baltimore Water System (Hydraulic Schematic)

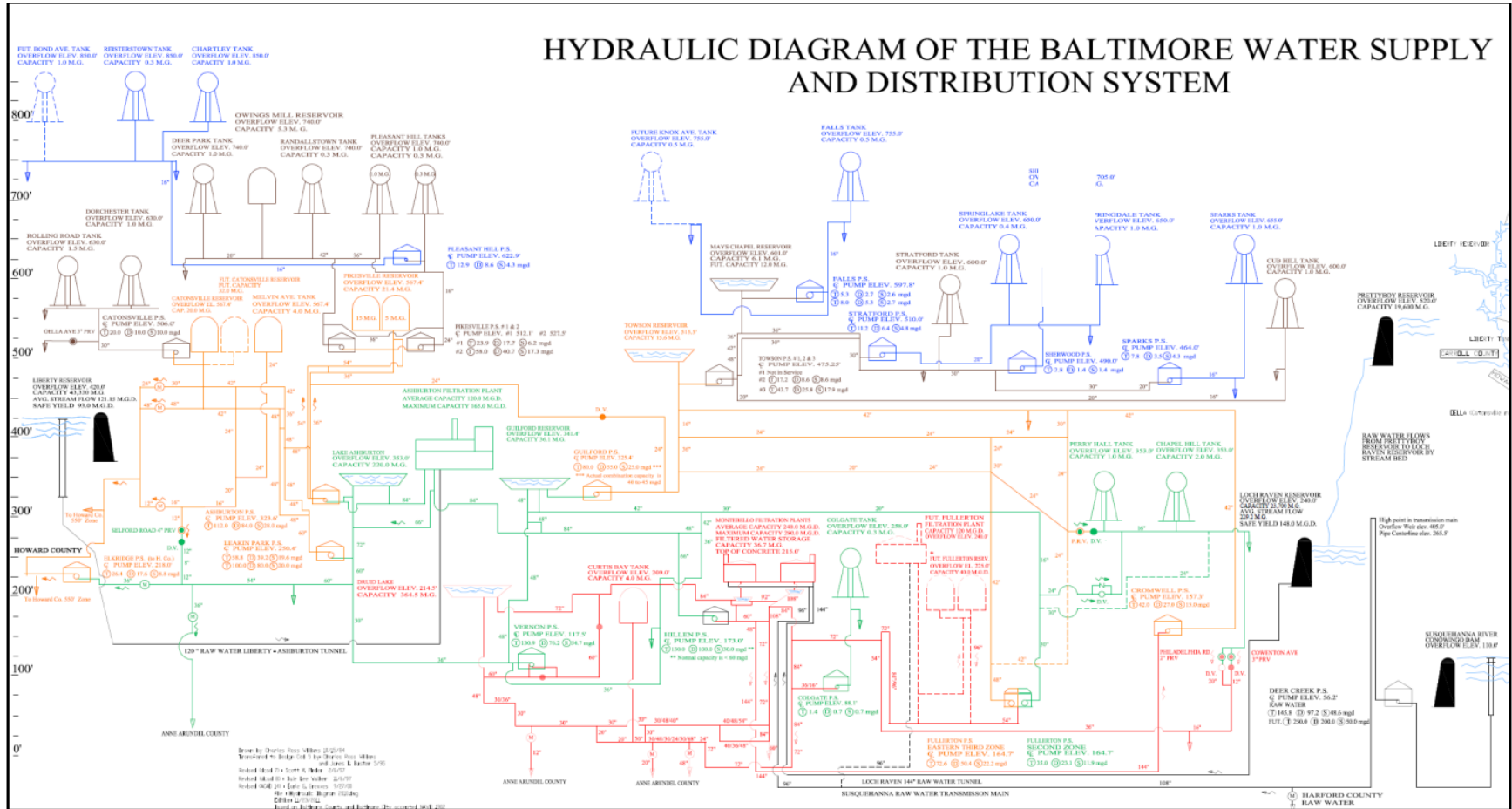

EXHIBIT B-1 - Howard County Water Service Area (Zone Map)

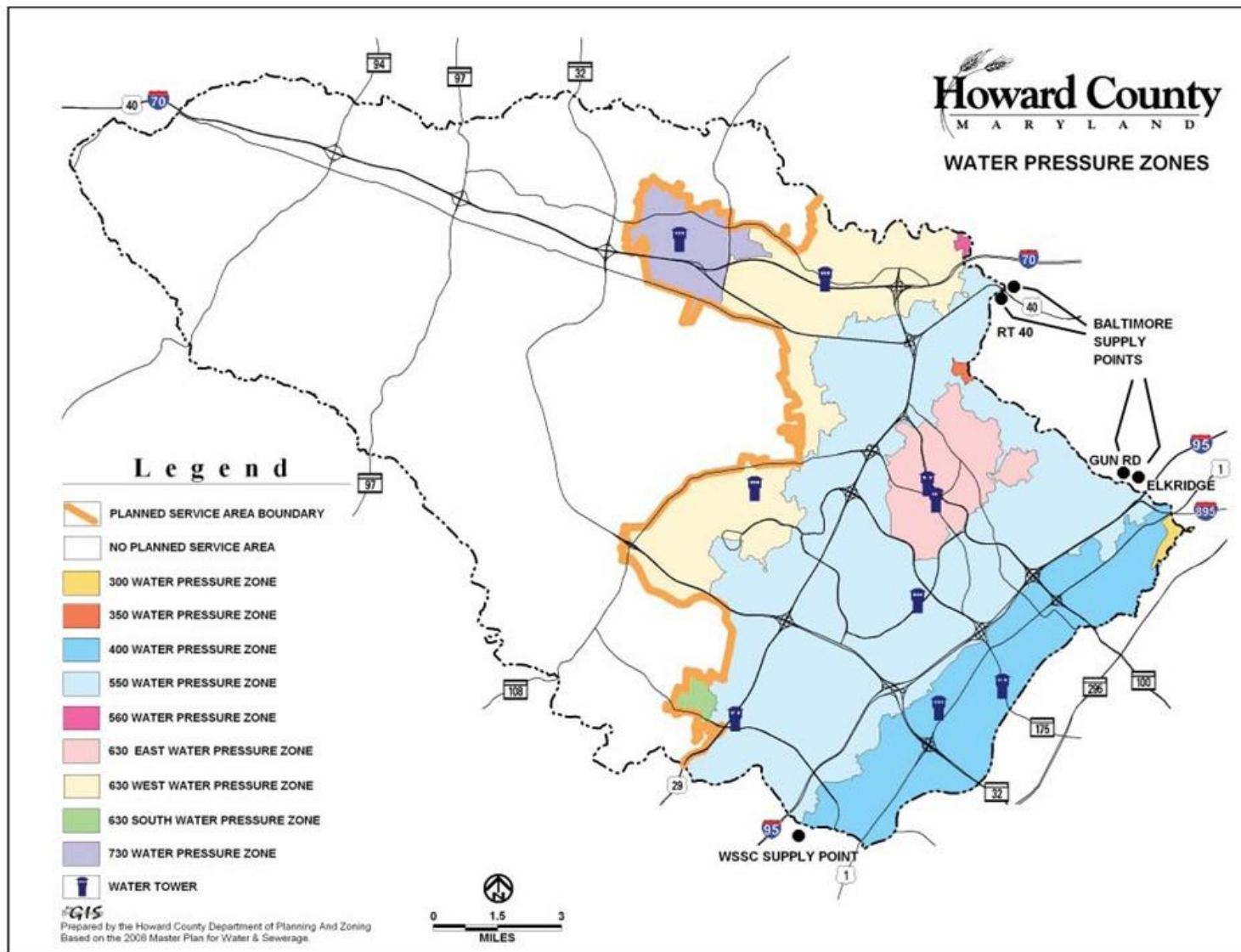

EXHIBIT B-2 – Howard County Water Service Area (Hydraulic Schematic)

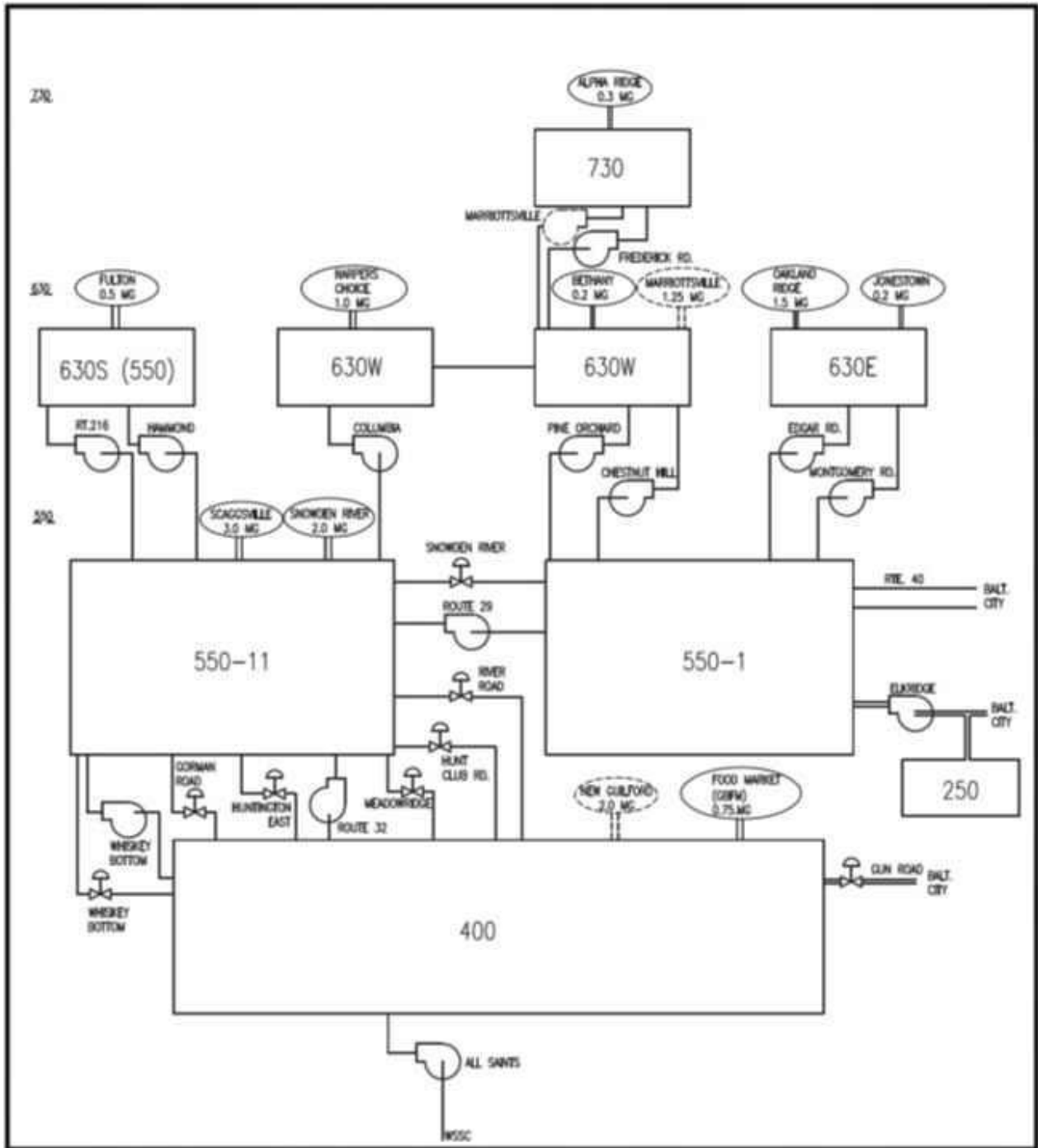

EXHIBIT C- Annual Statement of O&M Cost Allocation

Each year, the City shall submit to the County a statement showing computations of the County's share of O&M Costs for the preceding Fiscal Year. The computations shall be jointly reviewed and agreed upon by the City and County and shall be in accordance with the principles and methods of costing as set forth herein.

1. Definitions

1.1 "Water Analyzer Office" (also referred to as "Joint Planning Office") is the jointly staffed office established by Baltimore City and Baltimore County for the purpose of making detailed hydraulic, economic and statistical studies of the entire Baltimore Water System.

1.2 "Political Subdivision" is hereby defined as each of the governments of Baltimore City, Baltimore County, Anne Arundel County, Howard County, Carroll County and Harford County, or any other local governmental entity to which the City may supply water.

1.3 "System Volumetric Method" requires a tabulation of 'the actual quantity of treated water, including Zonal Non-revenue Water, supplied to each Political Subdivision in all of the Zonal Distribution Systems. Ratios of cost responsibility shall be developed by dividing the actual quantity of treated water, including Zonal Non-revenue Water, supplied to each Political Subdivision by the total quantity of treated water supplied to all the Political Subdivisions.

1.4 "Billed Unmetered Water Consumption" is hereby defined as the number of flat rate water service bills issued during the current Fiscal Year for the First Zone multiplied by 13,300 cubic feet per year and the number of flat rate water service bills issued during the current Fiscal Year for the Second Zone multiplied by 19,500 cubic feet per year.

1.5 "Zone" is hereby defined as a subdivision of the Core System in which a uniform static pressure range is maintained. The Zones of the Baltimore Water System are identified by numerical and regional values such as the First Zone, Second Zone, Western Third Zone, Eastern Third Zone, etc. as illustrated on Exhibit A-1.

1.6 "Zonal Distribution System" is the network of pipelines within a Zone that conveys treated water from a treatment plant, a water pumping station, or a water storage reservoir or tank to the consumer.

1.7 "Zonal Non-revenue Water" (formerly referred to as "Zonal Unaccounted Water") is hereby defined as the difference between the quantity of treated water supplied to the Zone and the sum of: (a) billed metered water consumption within the Zone, (b) Billed Unmetered Water Consumption, and (c) quantity of treated water delivered to other zones.

1.8 "Zonal Volumetric Method" requires a tabulation of the quantity of treated water, including non-revenue water, actually supplied to each Political Subdivision in the Zonal Distribution System or Systems served by said pipelines, pumping stations, and/or storage facilities. Ratios of cost responsibility shall be developed by dividing the quantity of treated water, including non-revenue water, actually supplied to each Political Subdivision by the total quantity of treated water, including

non-revenue water, actually supplied to all the Political Subdivisions served by said pipelines, pumping stations, and/or storage facilities.

2. Operation and Maintenance of the Baltimore Water System

The County shall, on an annual fiscal year basis, pay its proportionate share of all expenses resulting from the operation, maintenance and administration of the transmission, transportation and treatment facilities that constitute the Core System.

2.1 All expenses, exclusive of debt and equity, involved with the operation, maintenance, and administration of the following facilities and/or functions shall be proportioned by the System Volumetric Method:

- a. The treatment of raw water.
- b. The general supervision of the administration section for the Core System except for the costs of personnel and their associated office expenses assigned to the Joint Planning office.
- c. The engineering services for the Core System not charged to specific projects.
- d. The operation and maintenance of all pipelines in the Core System.
- e. The storerooms and yards utilized in the operation and maintenance of the Core System.

2.2 All expenses, exclusive of debt and equity, involved with the operation, maintenance and administration of the following facilities shall be proportioned by the Zonal Volumetric Method:

- a. The chlorinator stations operating in conjunction with the Core System water pumping stations, storage reservoirs and tanks in the Baltimore Water System.
- b. The Core System water pumping stations supplying the Baltimore Water System.
- c. The Core System water storage reservoirs and tanks supplying the Baltimore Water System.

2.3 The County shall not be responsible for any expenses whatsoever involved in the operation, maintenance, and administration of the following facilities and functions rendered by the City to Baltimore County and other Political Subdivisions.

- a. The engineering services rendered by the City on projects for Baltimore County and other Political Subdivisions.
- b. The field inspection rendered by the City on projects for Baltimore County and other Political Subdivisions.
- c. The installation and repair of water meters and the investigation of complaints within Baltimore County and other Political Subdivisions.

- d. The services including postage rendered by City water consumer services for Baltimore County and other Political Subdivisions.
- e. The operation and maintenance of the Zonal Distribution Systems within Baltimore County and other Political Subdivisions.

EXHIBIT D – Cost-of-Service Wholesale Rate Model

1. Basic Principles

The Model uses the utility basis approach to determine the cost of purchased water for the County. Under this approach, three cost components are determined: Operating and Maintenance costs, depreciation and Return. The Model is used to determine each of these cost components and allocates them to the County based on its actual and potential demand on the Baltimore Water System.

2. External Source Documents

The external source documents used to construct the cost of service model include:

- The City's Comprehensive Annual Financial Report
- The City's Annual Statement for O&M Cost Allocation
- Annual Capital Improvements Plan
- Detailed Water System Assets (Post June 30, 1990)
- Detailed Water System Assets (Prior to and including June 30, 1990)
- Wholesale Customer Capital Contributions

3. Model Overview

The Model consists of seven (7) schedules used to determine and display the annual cost of wholesale water purchases. A description of each of the schedules is provided below:

Schedule 1 - Cost of Service Summary:

This schedule provides the projected wholesale purchase costs by rate components for the County for the prospective Fiscal Year. The schedule shows the wholesale cost determination by component (O&M, depreciation and Return) and calculates the Volumetric Rate, Volume Charge and Fixed Charge.

Schedule 2 - Cost of Service Inputs:

This schedule identifies the City's investments in the Baltimore Water System on a summary level including the City's current capital assets net of depreciation, current assets net of current liabilities, restricted assets net of restricted liabilities and annual depreciation. The information is taken from the CAFR. The Baltimore Water System assets and depreciation are projected forward based on the City's Capital Improvement Program (CIP) which is inputted on this schedule. This information is used to determine the Rate Base.

The schedule also includes the calculation of the Rate of Return. Information used to determine the Rate of Return includes the City's current debt obligations, the embedded interest rate on the City's debt and the 6% equity premium. This schedule calculates the weighted average cost of capital used in the determination of the Return.

The schedule also calculates the value of the Core System by pulling the total value of the Core System assets from Schedules 6 and 7 and determining the percentage comprised by the Core System of the total Baltimore Water System.

Schedule 3 - Units of Service:

This schedule identifies the annual metered water use for the County and the average day flow commitment of 38.50 MGD and maximum day flow commitment of 57.75 MGD. The only data that is used from this schedule is the water commitment for the County which equates to 16.04% of the total Baltimore Water System capacity. The commitment percentage is used to allocate the County's share of Capital Costs (depreciation and Return).

Schedule 4 - Operating and Maintenance Expenses:

This schedule documents the detailed operating and maintenance expenses for each of the counties serviced by the City. The data is all hard entered from the Annual Statement for O&M Cost Allocation. The schedule defines the operating and maintenance costs for the County and is used to determine the Volumetric Rate.

Schedule 5 - Customer Contributions:

This schedule documents the historical capital contributions the County has made in the Baltimore Water System. The schedule is used to reduce the amount the County pays in Capital Costs (Return) by the amount of the capital contributions. This schedule should remain static in future years as the County no longer provides capital contributions to the City.

Schedule 6 - Rate Base - Plant in Service Since 1990:

This schedule details the physical assets within the Baltimore Water System that have been in service since June 30, 1990. The data includes identification of specific system assets, the year they were placed in service, useful life, original cost, the annual depreciation on the assets and most importantly identifies what portion of the asset is considered to be Core System. The total value of the Core System assets is used to determine a percentage of the total Baltimore Water System assets that have been in place since June 30, 1990.

Schedule 7 - Rate Base - Plant in Service Prior to 1990:

This schedule details the physical assets within the Baltimore Water System that were placed in service prior to and including June 30, 1990. Similar to Schedule 6 this schedule identifies the assets and allocates what portion of each asset is considered Core System. The total value of the Core System assets is used to determine a percentage of the total Baltimore Water System assets that were placed in service prior to and including June 30, 1990.

4. Procedure for Calculation of the Fixed Charge

The accompanying Table 1 provides the detailed methodology of the mathematical formulas embedded within the Model that determines Howard County's share of the Core System annual costs for the Rate Base and depreciation, which are used to calculate the Fixed Charge.

**TABLE 1:
PROCEDURE FOR CALCULATING THE HOWARD COUNTY ANNUAL FIXED CHARGE CONSISTING
OF THE CORE SYSTEM DEPRECIATION AND THE RETURN ON RATE BASE**

The data for existing and projected assets, liabilities, depreciation, and Rate of Return are entered here from the Cost of Service Input table ('COS Input' tab), which is a summary of input data from the additional detailed schedules that comprise the Cost of Service Model.

1. DETERMINE THE CORE SYSTEM PERCENTAGE OF TOTAL SYSTEM ASSETS

	FY 2014 CAFR Pre-Final Audit
1. Total value of system assets, from the 'COS Input' tab, Core System Determination	\$1,173,286,849
2. Value of Core System assets, from the 'COS Input' tab, Core System Determination	<u>\$803,165,445</u>
3. Core System percentage, Line 2 divided by Line 1	68.4543%

2. DETERMINE HOWARD COUNTY'S SHARE OF THE CORE SYSTEM DEPRECIATION

The below calculations demonstrate the methodology within the Cost-of-Service Model for calculating the Howard County share of the annual depreciation of the Core System ("Core System Depreciation").

- Step 1- Obtain the total system depreciation for the Baltimore Water System
- Step 2- Determine the annual Core System depreciation from the total system depreciation
- Step 3- Determine Howard County's share of the annual Core System depreciation
- Step 4- From the result of Step 3, subtract the annual depreciation of the previous capital contributions that were paid by Howard County toward construction of Core System assets. The result is Howard County's share of the annual Core System Depreciation.

Calculation of the Howard County share of the annual Core System depreciation:

	FY 2018 CAFR Projection
A. Determine the annual depreciation of the Core System	
1. Total system depreciation, from the 'COS Input' tab, CAFR Inputs block	\$31,775,158
2. Core System percentage, from the above Core System determination	<u>68.4543%</u>
3. Core System depreciation, multiply Line A1 by Line A2 =	\$21,751,466
B. Determine Howard County's share of the Core System	
1. Howard County's Contracted Capacity, from the 'Units of Service' tab, Total System Capacity block, Peak Day Commitment (MGD)	57.75
2. Total Capacity of Baltimore Water System, from the 'Units of Service' tab, Total System Capacity block, Peak Day Commitment (MGD)	<u>360.00</u>
3. Howard County's share of the Core System, divide Line B1 by Line B2 =	16.0417%
C. Howard County's share of Core System depreciation, multiply Line A3 by Line B3 =	\$3,489,298
D. Credit for previous Howard County contributions that were paid toward the Rate Base	
The annual depreciation of previous capital contributions paid by Howard County toward construction of Core System assets for the Base Year FY 2014 is \$760,024. Refer to the 'Contributions' tab and the Annual Depreciation of Contribution block. For projections beyond FY 2014, the annual depreciation of previous contributions decays based on the useful lives of the assets.	
The annual depreciation of \$760,024 reduced for each FY following FY 2014 =	\$619,044
E. Howard County's share of the annual Core System depreciation, Line C minus Line D =	\$2,870,253

Exhibit D- Table 1

3. DETERMINE HOWARD COUNTY'S SHARE OF THE CORE SYSTEM RETURN ON RATE BASE

The below calculations demonstrate the methodology within the Cost-of-Service Model for calculating the Howard County share of the annual Return on Rate Base of the Core System:

- Step 1- Multiply the Rate Base for the Core System ("Core System Rate Base") by the Howard County share of the Core System capacity commitments.
- Step 2- From the result of Step 1, subtract the depreciated value of previous capital contributions paid by the County toward construction of the Core System assets.
- Step 3- Multiply the result of Step 2 by the blended Rate of Return.

Calculation of the Howard County share of the annual Return on Rate Base of the Core System:

	<u>FY 2018 CAFR Projection</u>
A. Determine Core System Rate Base	
1. Total value of the Rate Base, from the 'COS Input' tab, CAFR Inputs	\$1,668,037,986
2. Core System percentage, from the 'COS Input' tab, Core System Determination	<u>68.4543%</u>
3. Core System Rate Base, Line A1 times Line A2 =	\$1,141,843,934
B. Determine Howard County share of the Rate Base	
1. Howard County Contracted Capacity, from the 'Units of Service' tab, Total System Capacity block, Peak Day Commitment (MGD)	57.75
2. Total Capacity of Baltimore Water System, from the 'Units of Service' tab, Total System Capacity block, Peak Day Commitment (MGD)	<u>360.00</u>
3. Howard County share of the Core System, divide Line B1 by Line B2 =	16.0417%
C. Value of previous Howard Co. depreciated contributions paid to Rate Base	
The depreciated value of previous capital contributions paid by Howard County toward construction of Core System assets for the Base Year FY 2014 is \$28,282,655. Refer to the 'Contributions' tab and the Depreciated Contributions block. For projections beyond FY 2014, the value of previous contributions depreciates based on the useful lives of the assets.	
Reduce the depreciated value of \$28,282,655 for each FY following FY 2014 =	\$25,242,566
D. Howard County Return on Rate Base	
1. Return on debt (Interest Expense), from 'COS Input' tab, Rate of Return block	4.5502%
2. Return on equity premium, from 'COS Input' tab, Rate of Return block	6.0000%
3. Return on equity, Line D1 plus Line D2=	10.5502%
4. System equity, from 'COS Input' tab, Rate of Return block	\$682,080,363
5. System debt, from 'COS Input' tab, Rate of Return block	\$619,443,000
6. Blended Rate of Return, based on assets and debt	
Return on debt, multiply Line D1 by Line D5 =	\$28,186,019
Return on equity, multiply Line D3 by Line D4 =	\$71,960,979
Blended Rate of Return, add the Return on debt and Return on equity from Line D6, then divide by the sum of the system equity and system debt from Lines D4 and D5 =	7.6946%
7. Return on Rate Base, multiply Line A3 by Line B3, then subtract Line C, and multiply by the blended Rate of Return from Line D6 =	\$12,151,943
HOWARD COUNTY FIXED CHARGE	
Depreciation, from Line 2.-E	\$2,870,253
Return on Rate Base, from Line 3.-D7	\$12,151,943
TOTAL FIXED CHARGE	\$15,022,197

Exhibit D- Table 1

4. SOURCE OF DATA INPUT VALUES

Below are values that must be entered into the Cost of Service Wholesale Model from other sources, or calculated from the values that have been entered into the model from other data sources.

A. Core System Percentage Calculation

The Core System percentage is calculated from the City's inventory of total system assets and the inventory of Core System assets using original costs for the assets placed in service.

B. Depreciation Calculation

The total system depreciation entered on Line A1 of the Depreciation Calculation is a data input value from the City's inventory of assets.

C. Rate Base Calculation

	FY 2013 CAFR INPUTS Final	FY 2014 CAFR INPUTS Pre-Final Audit
Total Rate Base	\$1,026,480,072	\$1,087,941,363
Net Current Assets	\$58,437,000	\$75,232,000
Net Restricted Assets	\$61,237,000	\$138,350,000
Depreciated Contributions paid to the Rate Base		
By Anne Arundel County	\$8,500,834	\$8,088,322
By Howard County	\$29,042,678	\$28,282,655
TOTAL SYSTEM ASSETS	\$1,108,610,560	\$1,301,523,363
System Debt	\$495,275,000	\$619,443,000
System Equity	\$613,335,560	\$682,080,363

EXHIBIT E- Compliance Documents

[Placeholder]

EXHIBIT F – Emergency Contacts for Water Supply and Water Quality Issues

1. Baltimore City

Baltimore City Department of Public Works
200 Holliday St.
Baltimore, MD 21202
Phone: 410-396-

Director Department of Public Works, Rudy Chow Office Phone: 410-396-3310
E-mail: Rudy.Chow@Baltimorecity.gov
Mobile Phone: 240-687-4237

Acting Bureau Head of Water & Wastewater, Jay Price Office Phone: 410-396-3500
E-mail: James.Price@Baltimorecity.gov
Mobile Phone: 667-203-0842

Acting Div. Chief of Environ. Serv., Deborah Pitts Office Phone: 410-396-0539
E-mail: Deborah.Pitts@Baltimorecity.gov
Mobile Phone: 667-209-7616

Water Systems Pumping Manager, Billy Dove Office Phone: 410-396-0360
E-mail: William.Dove@Baltimorecity.gov
Mobile Phone: 410-387-1531

2. Howard County

Howard County Bureau of Utilities
8250 Old Montgomery Road
Columbia, Maryland 21045
General office phone: 410-313-4900

Bureau Chief, Office Phone: 410-313-4912
E-mail:
Mobile Phone:

Utilities Operations Superintendent, George Gibson Office Phone: 410-313-4971
E-mail: ggibson@howardcountymd.gov
Mobile Phone: 443-802-9123

Utilities Facilities Superintendent, Bob Funk Office Phone: 410-313-1222
E-mail: bfunk@howardcountymd.gov
Mobile Phone: 443-844-9582

Evening, Weekend and Holidays 24-Hour Central Dispatch: 410-313-2929