

County Council Of Howard County, Maryland

2021 Legislative Session

Legislative Day No. **1**

Resolution No. 12-2021

Introduced by: The Chairperson at the request of the County Executive

A RESOLUTION pursuant to Section 16.1203 of the Howard County Code, adopting a new Forest Conservation Manual; and generally relating to Howard County Forest Conservation.

Introduced and read first time _____, 2021.

By order _____
Diane Schwartz Jones, Administrator

Read for a second time at a public hearing on _____, 2021.

By order _____
Diane Schwartz Jones, Administrator

This Resolution was read the third time and was Adopted___, Adopted with amendments___, Failed___, Withdrawn___, by the County Council on _____, 2021.

Certified By _____
Diane Schwartz Jones, Administrator

NOTE: [[text in brackets]] indicates deletions from existing law; TEXT IN SMALL CAPITALS indicates additions to existing law; Strike-out indicates material deleted by amendment; Underlining indicates material added by amendment

1 **WHEREAS**, Subtitle 12 "Forest Conservation" of Title 16 "Planning, Zoning and
2 Subdivisions and Land Development Regulations" of the Howard County Code requires certain
3 subdivisions and developments to have an approved Forest Conservation Plan prepared pursuant
4 to the Howard County Forest Conservation Manual; and

5
6 **WHEREAS**, Section 16.1203 "Forest Conservation Manual" of the Code requires that
7 the Forest Conservation Manual be prepared by the Department of Planning and Zoning and
8 adopted by resolution of the County Council, and further specifies that the Manual shall include
9 certain elements, including specific standards and guidelines; and

10
11 **WHEREAS**, the current version of the Forest Conservation Manual was adopted by
12 Council Resolution No. 10-1998; and

13
14 **WHEREAS**, by passage of Council Bill No. 62-2019, the Forest Conservation Act was
15 repealed and replaced, and updates are needed to the Forest Conservation Manual to be
16 consistent with the new Act; and

17
18 **WHEREAS**, the Department of Planning and Zoning has prepared a new Forest
19 Conservation Manual, substantially in the form attached to this Resolution.

20
21 **NOW, THEREFORE, BE IT RESOLVED** by the County Council of Howard County,
22 Maryland, this _____ day of _____, 2021 that it repeals the Forest Conservation
23 Manual adopted by Council Resolution No. 10-1998 and that it adopts the Forest Conservation
24 Manual, substantially in the form attached to this Resolution.

25
26 **AND BE IT FURTHER RESOLVED**, that the Department of Planning and Zoning
27 may correct obvious errors, capitalization, spelling, grammar, headings, page numbers and
28 similar matters and may format the Forest Conservation Manual by adding or amending covers,
29 title pages, table of contents, and graphics to improve readability.

D R A F T



HOWARD COUNTY
FOREST CONSERVATION
MANUAL

December 17, 2020

Prepared By:
Howard County Department of Planning & Zoning

ACKNOWLEDGEMENTS

COUNTY EXECUTIVE

Calvin Ball

COUNTY COUNCIL

Liz Walsh, District 1

Opel Jones, District 2

Christiana Rigby, District 3

Deb Jung, District 4

David Yungmann, District 5

DEPARTMENT OF PLANNING AND ZONING

Amy Gowan, Director

Peter Conrad, Deputy Director

Mary Kendall, Deputy Director

Jeff Bronow, Chief, Research Division

Beth Burgess, Chief, Resource Conservation Division

Anthony Cataldo, Chief, Land Development Division

Chad Edmonson, Chief, Development Engineering Division

Geoff Goins, Chief, Zoning Administration and Public Service

Kristin O'Connor, Chief, Comprehensive and Community Planning

CONTRIBUTING STAFF

Scott Bowen, Department of Recreation and Parks

David Keane, Department of Recreation and Parks

Brenda Luber, Land Development Division, DPZ

William Mahoney, Office of Community Sustainability

Susan Overstreet, Resource Conservation Division, DPZ

Jeannette Anders, Department of Planning and Zoning, Retired

Cindy Hamilton, Department of Planning and Zoning, Retired

Elmina Hilsenrath, Department of Planning and Zoning, Retired

Kent Sheubrooks, Department of Planning and Zoning, Retired

TECHNICAL ADVISORY COMMITTEE

Angelica Bailey, (former) Vice President of Government Affairs, MD Building Industry Association

Jennifer Bird, KCI Technologies

John Canoles, Principal, Eco-Science Professionals

Erik Fisher, Maryland Assistant Director, Chesapeake Bay Foundation

Craig Highfield, Director of Chesapeake Forests Program, Alliance for the Chesapeake Bay

Scott McGill, Ecotone

Greg O'Hare, Manager, Natural Resources, RKK

Keith Ohlinger, Vice President, Maryland Forests Association

Mike Tran, Gutschick, Little & Weber

Michael Trumbauer, Senior Restoration Ecologist, Biohabitats

Stephanie Tuite RLA, Fisher, Collins and Carter

Jason Van Kirk, Chair, Howard County Chapter MD Building Industry Association and Elm Street Development

FOR ADDITIONAL INFORMATION

This Manual, along with all required forms and applications, is available on the Department of Planning and Zoning web site.

<https://www.howardcountymd.gov/>

TABLE OF CONTENTS

CHAPTER 1: INTRODUCTION	1
1.0 BACKGROUND	1
1.1 PURPOSE OF THE MANUAL	1
1.2 FOREST	2
1.3 APPLICABILITY	2
1.4 DECLARATION OF INTENT	4
1.5 DIFFERENCES FROM OTHER APPROACHES	4
CHAPTER 2: FOREST STAND DELINEATION	5
2.1 PURPOSE AND APPROACH	5
2.2 SUBMISSION REQUIREMENTS	5
Figure 2-A: Example Site Vicinity Map	10
Figure 2-B: Example Forest Stand Assessment Map	11
Figure 2-C: Example Forest Stand Analysis Table	12
Figure 2-D: Example Forest Stand Delineation Narrative	13
2.3 COMBINED FOREST STAND DELINEATION AND FOREST CONSERVATION PLAN SUBMISSION	15
CHAPTER 3: FOREST CONSERVATION PLAN	16
3.0 INTRODUCTION	16
3.1 SUBMISSION REQUIREMENTS	16
3.2 NET TRACT AREA	18
3.3 CALCULATING FOREST CONSERVATION OBLIGATIONS	22
3.4 PREFERRED MITIGATION LOCATION	25
3.7 COORDINATION WITH OTHER SITE ISSUES	42
3.8 PREFERRED METHODS FOR REFORESTATION AND AFFORESTATION	44
3.9 REFORESTATION AND AFFORESTATION PLANTING PLANS	48
3.10 PROTECTION PROGRAMS	54
3.11 FEE-IN-LIEU REQUESTS	55
3.12 VARIANCE REQUESTS	56
CHAPTER 4: IMPLEMENTATION TECHNIQUES AND PRACTICES	58
4.0 INTRODUCTION	58
4.1 CONSTRUCTION PERIOD GENERAL PRACTICES	58
4.2 Forest RETENTION AREA protection procedures	60
Figure 4-A: Mitigating Construction Impacts on Forest Retention Areas	62
4.3 PLANTING PROCEDURES	66
Figure 4-B: Planting and Maintenance Calendar	70
4.4 Maintenance and Monitoring OF PLANTED AREAS	72
4.5 POST-CONSTRUCTION protection PRACTICES	76
4.6 LONG-TERM protection RESPONSIBILITIES	79
CHAPTER 5: PROGRAM ADMINISTRATION	80
5.1 INTRODUCTION	80
5.2 QUALIFIED PROFESSIONALS	80
5.3 ORGANIZATION OF THE HOWARD COUNTY PROGRAM	81
5.4 REVIEW OF PLANS	81

5.5	MAJOR SUBDIVISION AND NONRESIDENTIAL SUBDIVISION PLAN PROCESS	82
5.6	MINOR SUBDIVISION PLAN PROCESS	82
5.7	OTHER PLAN AND PERMIT PROCESSES	83
5.8	MITIGATION BANK	84
5.9	INSPECTION AND ENFORCEMENT	85
5.10	NONCOMPLIANCE AND PENALTIES	86
5.11	FOREST CONSERVATION EASEMENT	86
5.12	FOREST CONSERVATION AGREEMENT	87
5.13	ABANDONMENT or relocation OF RECORDED EASEMENTS	87
5.14	FOREST CONSERVATION FUND	89
5.15	ACCOUNTABILITY TO THE STATE	89
	Figure 5-A: Program Administration Responsibilities	90
	Figure 5-B: Major Subdivision and Nonresidential Subdivision Plan Process	92
	Figure 5-C: Minor Subdivision Plan Process	94
	Figure 5-D: Site Development Plan Process	96
	Figure 5-E: Timber Harvesting Plan Process	97
	Figure 5-F: County Capital Improvement Project Process	98
	Figure 5-G: Linear Project Process	99
	Figure 5-H: Mitigation Bank Process	100
	Figure 5-I: Variance Requests Process	101

LIST OF APPENDICES

Appendix A: Glossary Of Terms	103
Appendix B: Declaration Of Intent Forms.....	109
Appendix C: Forms and Worksheet.....	120
Appendix D: Plant Lists.....	127
Appendix E: Sample Details And Specifications	135
Appendix F: Fee-In-Lieu Request Form.....	161
Appendix G: References And Resources.....	164
Appendix H: Forest Inspection Guidance.....	166

CHAPTER 1: INTRODUCTION

1.0 BACKGROUND

In 1991 the Maryland General Assembly passed the Forest Conservation Act, a law that requires all local jurisdictions to establish and to enforce controls on the disturbance of wooded areas when properties are developed. The Act has been incorporated in the Annotated Code of Maryland as Natural Resources Article, Section 5-1601 to 5-1613.

The State law specifies numerous standards and procedural steps that local jurisdictions must comply with in establishing their own programs. Each local jurisdiction is given authority to incorporate the basic requirements of the Forest Conservation Act into its own procedures and requirements for approval of subdivision plans, site development plans and grading permits.

The Howard County Forest Conservation Act was first passed in 1992 and became effective on January 1, 1993. The Act was repealed and replaced in December 2019 and the new Act became effective on February 5, 2020. The Howard County Forest Conservation Act implements many of the policies and actions of Howard County's General Plan to protect and restore forests and other native plant communities, and to secure better protection of environmental and landscape resources within new developments. The main intentions of the Howard County Forest Conservation Act are summarized below:

- When developing a site, keep intact as much of the existing forest resources as possible (retention).
- Protect rare, threatened and endangered trees, trees that are part of an historic site or associated with an historic structure, and specimen trees.
- If forest must be cleared, replant native forests (reforestation).
- On sites where no or very limited forest resources now exist, plant new native forest stands to create the minimum level of forest cover specified (afforestation).
- Protect all retained and newly planted forest with a Forest Conservation Easement.

1.1 PURPOSE OF THE MANUAL

This Manual presents the Howard County Program for implementing the Howard County Forest Conservation Act. The fundamental requirements of the Howard County Program are contained in Subtitle 12 of the Subdivision and Land Development Regulations. To guide applicants and their consultants in complying with the County Program and in coordinating such compliance with other regulatory requirements, this Manual:

- Explains the basic concepts and requirements of the Howard County Forest Conservation Act and the resulting County regulations.
- Identifies basic program goals such as the retention of forest within priority areas.
- Explains in detail the procedures to be followed at each stage of the submission and approval process for compliance with the obligations of the Forest Conservation Program.
- Provides guidelines and standards for implementing specific actions required as part of an approved Forest Conservation Plan.
- Explains procedures for enforcement of program requirements.

1.2 FOREST

A forest is a natural ecological community dominated by trees, generally including woody understory plants such as shrubs and young trees, and herbaceous vegetation such as grasses and flowers. Such areas are also wildlife habitats, since they provide food, shelter and cover for a variety of species. To be fully effective as a complex environmental community, forest areas need to be large enough to provide space for a variety of native plant and animal species, to afford protection from outside intrusions, and to be able to mature and regenerate themselves. The Forest Conservation Act defines forest areas to be at least 10,000 square feet, or about 1/4 of an acre, and a minimum of 35 feet in width for an existing forest and 50 feet for a replanted forest.

Existing and proposed overhead and underground utility maintenance areas and utility easements may not be included as part of a retained forest area, because these areas must be cleared and/or trimmed periodically to maintain access to the utility. Forest within existing utility maintenance areas or easements will not be given credit as existing forest, but adjacent sections of forest on either side of a utility maintenance area or easement may qualify as forest if they cumulatively fulfill the minimum size and width requirements, and the utility maintenance area or easement is 30 feet or less in width. If an existing utility does not have an associated easement, a minimum maintenance width of 10 feet should be assumed on each side of the utility.

Appendix A contains a more detailed definition of forest that includes a minimum number and size of trees per acre. While some individual trees are given special consideration (for example, State Champion trees, trees more than 30" in diameter, trees associated with historic structures), the emphasis of the Act is on forest communities, and the priorities of the Howard County Forest Conservation Program reflect this emphasis.

1.3 APPLICABILITY

All requests for approval of subdivision plans, site development plans, grading permits, or County road and utility projects shall comply with the procedures and requirements of the Howard County Forest Conservation Program. The following activities, as detailed in Section 16.1202(b) of the County Code, are exempt or exempt with a Declaration of Intent.

1.3.1 Exempt

The following activities are exempt.

1. Development activities on single lots smaller than 40,000 square feet, as long as the cutting, clearing or grading does not include any area already subject to a previously approved Forest Conservation Plan.
2. A planned unit development which has preliminary development plan approval and 50% or more of the land is recorded and substantially developed before December 31, 1992. If new land area is added to the planned unit development, that new land area is subject to this Program.
3. A planned business park of at least 75 acres which has preliminary plan approval before December 31, 1992, and which meets the intent of this subtitle by retaining forest in high priority locations (floodplains, wetlands, wetland and stream buffers, steep slopes, and wildlife corridors/Green Infrastructure Network).
4. Any agricultural activity, as defined in Appendix A, using accepted best management

- practices that involves cutting, clearing or grading less than 40,000 square feet of forest within a one-year period.
5. Agricultural preservation subdivisions that involve cutting, clearing or grading less than 20,000 square feet of forest.
 6. Resubdivisions that create no additional lots, deed adjoiners, property consolidations, reconfigurations and correction plats.
 7. Minor subdivisions that create one additional lot and have no further subdivision potential, based on the existing zoning.
 8. Mining or other extractive activity exempted by State law from the forest conservation requirements.
 9. Any routine maintenance of existing public rights-of-way for utilities or roads.
 10. Highway construction using full or partial State funding is exempt but subject to State reforestation requirements set forth in Natural Resources Article 5-103.
 11. Any cutting or clearing of public utility rights-of-way or land for electric generating stations licensed pursuant to Section 7-204, 7-205, 7-207 or 7-208 of the Public Utility Companies Article, if:
 - Required certificates of public convenience and necessity have been issued in accordance with Natural Resources Article 5-1603;
 - Cutting or clearing of the forest is conducted to minimize the loss of forest.
 12. Howard County capital improvement projects (including those with partial State funding) provided that the activity is conducted on a single lot of any size, the activity does not result in the cutting, clearing or grading of more than 20,000 square feet of forest, and the impacted forest is not subject to a previously approved Forest Conservation Plan.
 13. Any activity on a previously developed area covered by an impervious surface created under an approved plan or permit, and located in the Priority Funding Area.
 14. Maintenance or retrofitting of a stormwater management structure that may include clearing of vegetation or removal and trimming of trees, so long as the maintenance or retrofitting is within the original limits of disturbance for construction of the existing structure, or within any maintenance easement for access to the structure.
 15. A stream restoration project, as defined in Appendix A, for which the applicant for a grading or sediment control permit has executed a binding maintenance agreement of at least 5 years with the affected property owner or owners.

1.3.2 Exempt with a Declaration of Intent

The following activities are conditionally exempt with a Declaration of Intent. A Declaration of Intent is described more fully in the following section. Note that obligations incurred under a Declaration of Intent are cumulative.

1. Residential development activities on a single lot or parcel of any size if the total area of forest to be cut, cleared or graded is less than 20,000 square feet, and if the lot or parcel is not subject to a previously approved Forest Conservation Plan. The limit of disturbance may extend off-site provided that the purpose of the disturbance is to facilitate the development of the single lot or parcel, and that the total area of forest cut, cleared or graded both on and off-site is less than 20,000 square feet.
2. Commercial logging and timber harvesting operations carried out in accord with required State and local timber harvest permit procedures.
3. Any agricultural activity, as defined in Appendix A, using accepted best management practices involving the cutting, clearing or grading of 40,000 square feet of forest or more per year.
4. Subdivision to permit a real estate transaction, as defined in Appendix A, that does not

- involve a change in land use, new development or redevelopment.
5. Linear projects, as defined in Appendix A, that are not exempt (as described above) and that disturb less than 20,000 square feet of forest, if the impacted forest is not subject to a previously approved Forest Conservation Plan.

1.4 DECLARATION OF INTENT

The Declaration of Intent serves two purposes. First, filing a Declaration of Intent notifies those responsible for administering the Forest Conservation Program that any cutting, clearing or grading resulting from the conditionally exempt activity does not require a Forest Conservation Plan. Second, filing a Declaration of Intent results in a written reminder to all parties that the exemption from forest conservation obligations is contingent on no subsequent activity regulated by the Forest Conservation Program occurring within five years of completing the conditionally exempted activity. Appendix B contains the forms to be used when filing a Declaration of Intent.

If a request for a nonexempt activity (subdivision, site development plan or grading permit) is made within five years of completing an activity that is the subject of a Declaration of Intent, the forest conservation obligations of the proposal will be retroactive to cover the forest resources that existed at the time the Declaration of Intent was filed. For example, a site has 70 acres of net tract area that are all forested. A timber harvesting permit application and a Declaration of Intent are filed for commercial logging. Some 60 acres of trees are cut; 10 acres remain intact. However, within five years the owner applies for approval to subdivide. The forest conservation obligations of the proposed subdivision would be calculated on the basis of the original 70 acres of forest, not the 10 acres that were undisturbed.

1.5 DIFFERENCES FROM OTHER APPROACHES

The basic concept and goals of the Forest Conservation Program differ from the approaches of many traditional tree preservation or landscaping ordinances.

- The Forest Conservation Act is not a tree preservation act. While some individual trees are protected by the Forest Conservation Program (for example, Champion trees or those associated with historic structures), the emphasis is on forest communities.
- There are no fixed minimum forest retention requirements that must be adhered to. The goal is no more clearing of forests than necessary.
- Reforestation thresholds are not minimum requirements. Rather, the reforestation threshold is used to calculate whether and how much reforestation may be required to compensate, in part, for whatever clearing may be unavoidable.
- The Program not only controls loss of existing forest resources, it also requires creation of new native forest communities where trees are absent or minimal. The afforestation requirements are minimum standards. Depending on the amount of clearing on an afforestation site, some projects may require both afforestation and reforestation.
- Reforestation and afforestation are not landscaping as it is usually practiced. Reforestation and afforestation create new native forest communities that will replace to some degree the forest resources that are lost during land development. Their primary purpose is environmental, not aesthetic. Reforestation and afforestation stands will require special management and initially may not look attractive.

CHAPTER 2: FOREST STAND DELINEATION

2.1 PURPOSE AND APPROACH

The purpose of a Forest Stand Delineation (FSD) is to provide an inventory of the existing forest and other vegetation on and immediately adjacent to a site. This information is used to determine the most suitable and practical areas for forest conservation during the development process. All activities requiring a Forest Conservation Plan require a Forest Stand Delineation. An FSD uses a combination of resource mapping and field assessment to inventory and describe the existing forests and related environmental resources on the site. If forest conservation obligations will be met off-site, an FSD is also required for the off-site location. The information presented in the Forest Stand Delineation becomes the basis for decisions regarding retention, reforestation and afforestation.

Most of the information in a Forest Stand Delineation concerns trees, the dominant species in a forest community. Nevertheless, the emphasis of the Program on forest communities requires some description of the understory and herbaceous plants, the successional stage of the forest community, and other characteristics of the vegetation. The relationship of existing forest resources (or the absence of such cover) to soil types and environmentally sensitive areas, such as wetlands, steep slopes and stream buffers, is necessary to evaluate the retention, reforestation or afforestation proposals included in the required Forest Conservation Plan.

The Forest Stand Delineation requirements described in this Manual are relatively simple to implement yet detailed enough to adequately assess forest resources. Additional detail may be requested when specific conditions warrant. An approved FSD is valid for five years. The FSD must be updated, if the associated Forest Conservation Plan is not approved within five years of FSD approval.

2.2 SUBMISSION REQUIREMENTS

The Forest Stand Delineation submittal shall include a Forest Conservation Application, a Forest Stand Delineation Plan Sheet, a Classification of Forest Stands and Other Vegetation, Forest Stand Analysis Tables, and a Forest Stand Delineation Narrative.

2.2.1 Forest Conservation Application

This application form is available through the Department of Planning and Zoning (DPZ) and the DPZ web page.

2.2.2 Forest Stand Delineation Plan Sheet

The plan shall use many of the same base data sources as the initial subdivision, site development plan or grading plan submission; shall use criteria or definitions as required by the Howard County Subdivision and Land Development Regulations; and shall show the following information:

1. Base information.

- North arrow and scale (the scale should be the same as the associated development plan).
- Property boundaries.

- Topographic information (the interval should be the same as the associated development plan).
 - Gross area of site.
 - MDE 12-digit watershed boundaries and numbers.
- 2. Forest and Vegetation Information.** For guidance on defining and depicting this information, see the following section on Classification of Forest Stands and Other Vegetation.
- Current forested and unforested areas, forest stand locations and tree lines extending off-site.
 - Specimen trees: State Champion trees, trees 75% of the size (diameter) or greater of State Champion trees of the same species, and trees 30" in diameter or larger.
 - Historic trees: trees that are part of an historic site or that are associated with an historic structure.
 - Other significant vegetation (hedgerows, allees, ornamental plantings).
- 3. Environmental Features.**
- Howard County Green Infrastructure Network.
 - 100-year floodplains.
 - Steep slopes: 25% and greater and 15%-25%.
 - Critical habitats of rare, threatened or endangered species. (If a project site is located wholly or partially within a Sensitive Species Project Review Area, the submittal must include a comment letter from the Maryland Department of Natural Resources, Natural Heritage Program.)
 - Perennial and intermittent streams and stream buffers (see the Subdivision and Land Development Regulations for buffer requirements).
 - Soils, and indicate soils with an erodibility index (K) value greater than 0.35 on slopes of 15% or more, and hydric soils.
 - Nontidal wetlands and 25' wetland buffers.
- 4. Other Site Features.**
- Existing buildings, structures, walls, fences, roads, trails, underground and overhead utilities, and easements.
 - Adjacent land uses and zoning designations.
 - Historic structures or other historic resources, including trees and cemeteries (see Federal historic register or County or State inventories, in addition to site specific deed information and field inspection).
 - Other significant natural or built features (quarries, springs, ponds, rock outcrops, rubble landfills, dumps or disposal areas).
 - Agricultural best management practices designed to convey water above or below ground (diversions, grassed or lined waterways, irrigation systems, pipelines, subsurface drains or underground outlets).
- 5. Signature/seal of qualified professional who prepared the plan.** See [Section 5.2](#) for the definition of a qualified professional.
- 6. Site Vicinity Map.** The map shall include the site and the surrounding area within one-half mile of the site perimeter, indicating major roads, land uses, protected lands (parks, open space and easements), watershed boundaries, environmental features and forest cover. (Source: County topographic or GIS maps.) The map may be prepared at

approximately 1" = 1,000' scale, but the scale may vary based on the property size. Figure 2-A is an example of a site vicinity map.

2.2.3 Classification of Forest Stands and Other Vegetation

The Forest Conservation Act defines a forest as a biological community dominated by trees and other woody plants covering an area of 10,000 square feet or greater, with a minimum width of 35 feet for existing forest and 50 feet for planted forest. A forest includes: areas with a tree cover ratio of 100 trees per acre, with at least 50% of these trees being at least 2 inches in diameter at breast height (DBH), a height of 4.5 feet above ground; or areas meeting these criteria with trees that have been cut down, but the forest floor has not been cleared. A forest does not include orchards, tree nurseries, Christmas tree farms, silvopasture or other types of tree crops or plantations.

The Forest Stand Delineation plan sheet must delineate and label all vegetative plant communities. The required information about the vegetative plant communities must be obtained by field observation. The following list is a guideline for how to classify and label each plant community. Each community can be further subdivided into different stands depending on characteristics such as species groups, size groups and cover types. A forest stand is a community of trees sufficiently uniform in species composition, age, arrangement, and condition to be distinguishable as a group from the forest or other growth on the adjoining area. Forest stands occur because of similar growth conditions, for example: soil nutrients; soil drainage patterns; aspect; management and past conditions; selective thinning in recent years; abandonment of agricultural lands; and other factors. Figure 2-B shows how a site can be divided into a range of different plant communities and stands. Since there can be several types of forest or other plant communities within the same project, they can be identified by symbols (for example, F-1, F-2).

- Forest (F).
- Wetlands (other than forested) (W).
- Abandoned field (AF).
- Open field, pasture or meadow (not including lawns) (OF).
- Hedgerow (H).
- Tree groups that do not meet the definition of forest (T). These are typically tree groups with lawns or landscape beds beneath.
- Specimen trees (S).
- Historic trees (HT).
- Lawns, play fields and other turf areas - nonagricultural (L).
- Crops (areas actively tilled periodically to plant and harvest agricultural products) (C).
- Orchards (OR).
- Tree nurseries, Christmas tree farms or other types of tree crops or plantations (N).

2.2.4 Forest Stand Analysis Tables

Data collected by the field investigation shall be tabulated and summarized for each forest stand. Figure 2-C is an example using the required format. A blank form is provided in Appendix C. The information detailed on the forms shall describe:

- **Type of community/stand:** type of community/stand in accordance with the classification system discussed above.
- **Area:** the acreage of the community or stand, measured at a minimum to the nearest 1/10 acre.
- **Soil information:** soil types and typical forest cover for the soil type. The typical cover is

the type of plant community likely to be present if the area has been undisturbed. It is cited in the most recent edition of the Soil Survey of Howard County, Maryland.

- **Existing vegetation:** dominant tree species, including canopy and understory species, with approximate percentage, noting in particular if any are invasive exotic species.
- **Stand characteristics:** size range, successional stage and typical condition of dominant tree species.
- **Forest areas in sensitive environments:** area of forests, measured at a minimum to the nearest 1/10 acre in Green Infrastructure Network, critical habitats, floodplain, wetland and wetland buffer, stream buffer and steep slopes.

2.2.5 Specimen Trees and Historic Trees Table

Data collected by the field investigation shall also be tabulated and summarized for specimen trees and historic trees. Each tree should be marked in the field with an aluminum tag or a similar device that records the tree species and DBH.

Historic trees are part of a historic site and contribute to a significant view or setting, or they are associated with a historic structure. Large hardwoods, such as oaks, poplars and hickories, that have historic significance are often also specimen trees, with a DBH of 30 inches or greater. Smaller understory trees, such as dogwoods, sourwoods and redbuds, naturally have a smaller DBH and usually do not qualify as a specimen tree. To ensure smaller trees with historic significance are not overlooked, data must also be collected on understory trees with a DBH of 10 inches or greater on historic sites or sites with historic structures.

The information provided for each type of tree shall describe:

- **Specimen trees:** tree species, DBH, condition and specimen tree type (i.e. Champion tree, 75% or greater diameter of Champion tree for that species, or diameter 30" or greater).
- **Historic trees:** tree species, diameter and circumference measured at breast height, estimated age, condition and historic significance.

2.2.6 Forest Stand Delineation Narrative

The Forest Stand Delineation must include a written summary describing each forest stand. In general, the written summary shall assess the significance of the information required by the forest stand delineation table and note any special characteristics of the vegetation. The objective of the narrative is to evaluate each forest stand for potential retention. This evaluation will be used when preparing a Forest Conservation Plan and will be useful to subsequent designers and engineers planning the site. The level of detail for such descriptions may vary with the relative size, importance or complexity of the stand. The following information shall be included in the narrative when relevant:

- **Forest stand structure:** degree of canopy closure, condition of forest layers (canopy, understory and herbaceous), percent cover of downed woody debris, woody regeneration, presence of standing dead trees, and presence and percent cover of invasive exotic species.
- **Stand condition:** evaluation of each stand with reference to stand structure (dominant species, understory species), potential to withstand disturbance, potential for transplant material (both as a source and recipient of material), comments on evidence of past management.
- **Typical cover:** comparison of the typical cover for the soil group (available from the Soil Survey) to the existing cover. This information may provide indicators of past

management and be used as a guide for selecting species to be used in reforestation or afforestation.

- **Relationship to other environmental features:** forest stand location in reference to on- and off-site Green Infrastructure Network, floodplains, streams, wetlands, steep slopes, soils, habitats and land uses, such as parkland, open space and easements. The effect of existing or proposed development on habitat values should be noted.
- **Relationship to off-site forest:** the relationship of on-site and off-site forest, including an estimate of the extent of the described stand.
- **Habitat value:** the relative value of the stand as a source of food, cover and breeding area for common and migratory wildlife species.
- **Retention priority areas:** relation of the forest stand to the forest retention priority areas listed in Chapter 3. The FSD plan sheet may include certain elements of the narrative to correlate stand descriptions and stand priority for retention with the location of each stand and the environmental features.
- **Potential problems:** including higher than average probability of erosion if disturbed, poor soils for reforestation or afforestation, or soils prone to saturation or flooding, which can affect growth of certain species. Soil Survey information is an easy to use resource for flagging potential problems or opportunities, for example, as an indicator of potential problems if disturbance of forest cover occurs or of the inherent ability of the soil to support good forest growth. Explanations should be provided if soils have been seriously altered or if Soil Survey data appears to be in error. Problems that may have occurred because of past or present management, or because of disease, insects or invasive exotic plant invasion on the site should also be described.

Figure 2-D is an example of a Forest Stand Delineation narrative.

Figure 2-A: Example Site Vicinity Map

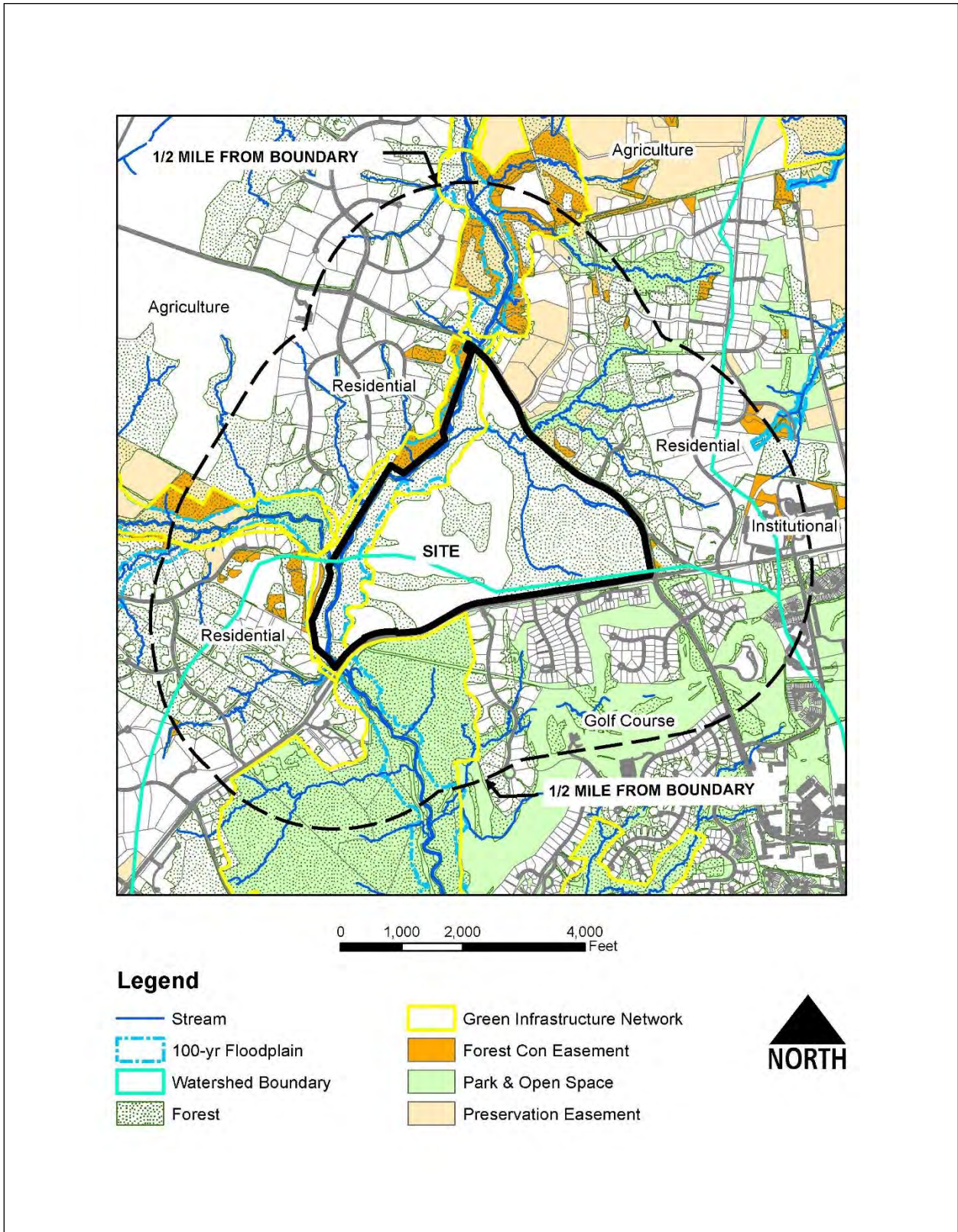

Figure 2-B: Example Forest Stand Assessment Map

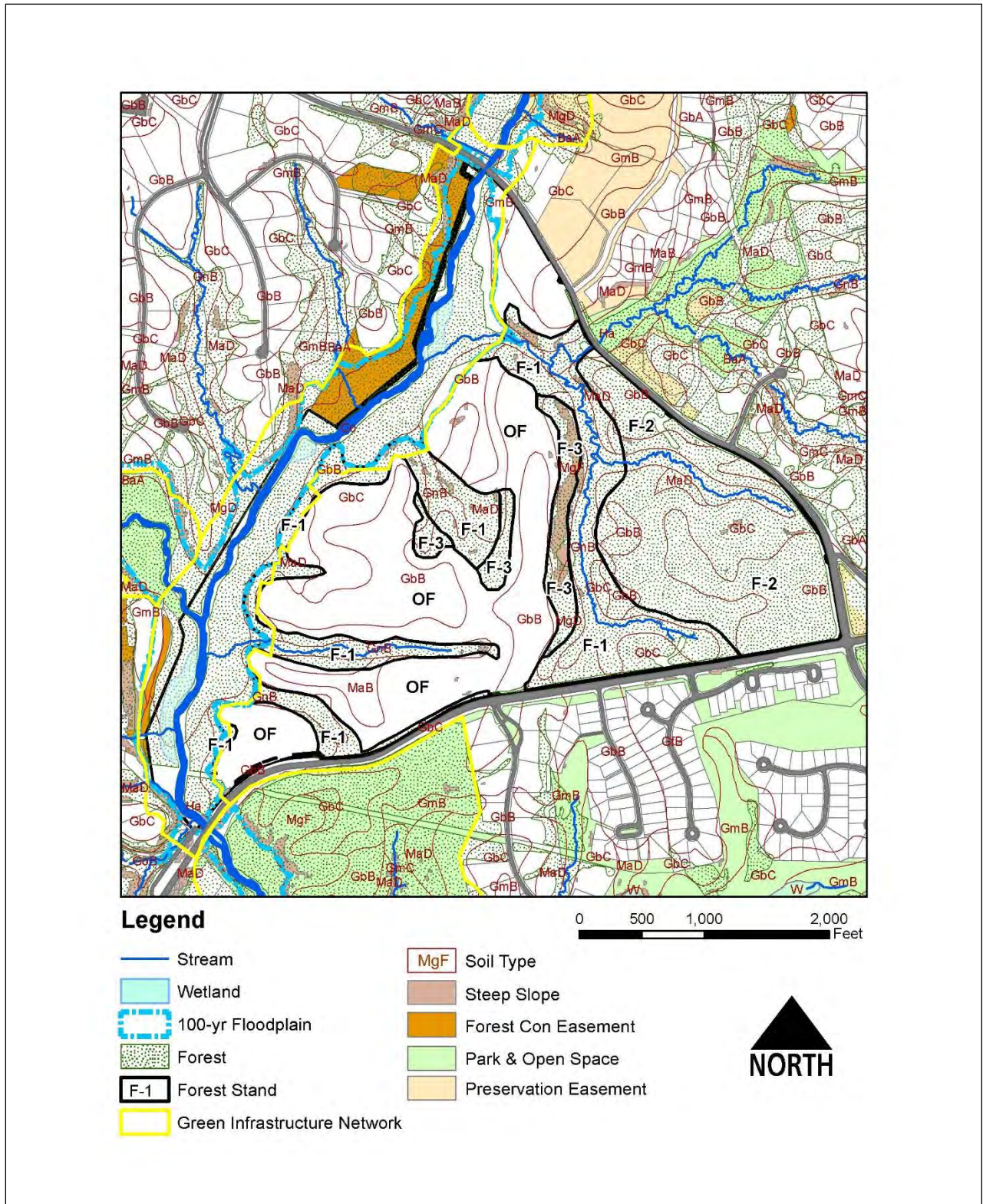

Figure 2-C: Example Forest Stand Analysis Table

Applicant: Jane Brown **Project Name:** Western Acres **Submission No:** SP-20-050

Key	Community Type	Community Area	Soil Type	Typical Tree Cover for Soil Type	Dominant Species	% Cover	DBH	Stand Successional Stage	Stand Condition	Community Area in Sensitive Environments
F-1	Tulip Poplar	66.9 ac	Co GbB GnB MaD	Mixed hardwoods Upland oaks, yellow poplar, ash, hickory Mixed hardwoods Oaks, yellow poplar, hickory, red maple, pines	<i>Liriodendron tulipifera</i> <i>Platanus occidentalis</i> <i>Acer rubrum</i> <i>Prunus serotina</i> <i>Fraxinus pennsylvanica</i>	30% 20% 20% 20% 15%	12-20" 12-20" 12-20" 12-20" 12-20"	Mid-successional	Good	35.0 ac in GIN, wetlands, stream and wetland buffers, steep slopes
F-2	Mixed Oak	62.6 ac	GbB & GbC	Upland oaks, yellow poplar, ash, hickory	<i>Quercus rubra</i> <i>Quercus alba</i> <i>Quercus velutina</i> <i>Liriodendron tulipifera</i> <i>Fagus grandifolia</i> <i>Carya glabra</i>	25% 25% 25% 15% 5% 5%	10-18" 10-18" 10-18" 10-18" 6-12" 6-12"	Mid-successional	Good	7.0 ac in wetlands, stream and wetland buffers, steep slopes
F-3	Successional	11.2 ac	GbC MgF	Upland oaks, yellow poplar, ash, hickory Oaks, yellow poplar, hickory, blackgum, red maple, pines	<i>Robinia pseudoacacia</i> <i>Liriodendron tulipifera</i> <i>Prunus serotina</i> <i>Acer rubrum</i> <i>Juglans nigra</i> <i>Morris alba</i> <i>Ailanthus altissima</i>	30% 20% 25% 10% 10% 5% 5%	8-16" 8-16" 8-16" 8-16" 6-12" 4-10" 4-10"	Early successional	Good	5.0 ac in stream buffer, steep slopes

Figure 2-D: Example Forest Stand Delineation Narrative

Three forest stands were identified on the subject property.

Stand F-1

Stand F-1 is a tulip poplar community forest, which occurs along the stream valleys and bottoms on the site, and occupies approximately 66.9 acres of the site. The canopy trees average approximately 12-20 inches diameter breast height (DBH) and are comprised in varying composition of tulip poplar, sycamore, red maple, green ash, black cherry and black locust. Overall canopy closure in the stand is approximately 80 percent. Tulip poplars define the stand's character. Sycamore and red maple are the most common associates in the stream bottoms and associated wetlands, and black locust and cherry are the most common associates on the slopes. Numerous wetland areas are present within this stand. While these areas occur beneath the poplar canopy, they are primarily distinguished by a red maple sub-canopy.

The stand has an understory dominated by red maple, green ash, black cherry, flowering dogwood and American hornbeam. The shrub layer is sparse with 40 percent closure. Spicebush, Japanese barberry, hornbeam, arrowwood, winterberry and multiflora rose are present in the shrub layer. The herbaceous layer includes Japanese stiltgrass, garlic mustard, Japanese honeysuckle and Christmas fern. Invasive exotic species cover is about 30% in the shrub layer and 60% in the herbaceous layer.

This stand shows little evidence of disease or insect infestation, although the green ash may soon be affected by emerald ash borer. Historic logging in the stand may have changed the composition of the dominant species, as some evidence of past logging activity is present in the stand. Selective cutting may have reduced the oak populations. There does not appear to be continuing management of the forest on the subject property.

To the west this forest is adjacent to a forested 100-year floodplain. This forest and the floodplain forest lie within a corridor in the County's Green Infrastructure Network (GIN). This corridor connects a large forested hub on parkland/open space to the south with a forested hub to the north on a preservation easement. This stand also provides a forested riparian corridor that connects to an off-site forested riparian corridor to the northeast that is located within parkland/open space.

Stand F-1 provides excellent wildlife habitat. Where this forest is adjacent to the floodplain forest, it is of sufficient size and configuration to provide forest interior habitat. Stand F-1 together with Stands F-2 and F-3, also provide forest interior habitat in the southeastern portion of the site. The riparian/wetland nature of this forest greatly enhances its value.

This stand contains roughly 35 acres of GIN, wetlands, wetland/stream buffers and steep slopes, which are high priority retention areas. Forest Stand F-1, with its forest interior habitat and numerous sensitive areas, is a high priority for retention.

Stand F-2

Stand F-2 is a mid-successional mixed oak forest located along the xeric ridges on the eastern end of the property. The stand occupies approximately 62.6 acres of the site and is dominated by red oak, white oak, black oak and tulip poplar. The average size of the dominant trees is within the 10-18" DBH range. It appears that this stand has been selectively logged in the past. This resulted in a secondary, successional oak dominated community. The sub-canopy of the stand is dominated by red maple, pignut hickory, American beech and black gum. Canopy closure in the stand is roughly 80 percent. The understory and shrub layers in the stand are moderately vegetated with young canopy trees and flowering dogwood being most evident.

Small groves of dense sapling regeneration, primarily poplar and black cherry, are scattered throughout the stand. The shrub layer contains Japanese barberry, blackhaw, maple-leaved viburnum, various blackberries and multiflora rose. Shrub closure is variable with denser shrub coverage along the west

facing slopes adjacent to the road and less shrub density on the east facing slopes near the center of the site. Invasive exotic species cover is about 30% in the shrub layer. The herbaceous layer includes Japanese stiltgrass, garlic mustard and Japanese honeysuckle. Invasive exotic species cover is about 50% in the herbaceous layer, although higher along the forest edges near the road.

The stand appears to be in good condition with some invasive exotic species impact but little evidence of disease or insect damage. Dumping of debris has occurred along trails that can be accessed from the road. Evidence of deer hunting was noted. A noticeable browse line was observed in this stand indicating that deer populations are high.

The habitat value of the stand is good. The stand has a diverse species composition and good potential for future growth. The oaks, hickory and beech trees provide mast for wildlife. In combination with Stands F-1 and F-3, this stand provides forest interior habitat. This forest stand also provides a buffer for a headwater stream that originates on this site.

This stand contains roughly 7 acres of wetlands, wetland/stream buffers and steep slopes, which are high priority retention areas. Forest Stand F-2, with its forest interior habitat and sensitive areas, is a high priority for retention.

Stand F-3

Stand F-3 is a successional forest community that occupies approximately 11.2 acres on the site. It occurs in an upland drainage way and along the edges of Stand F-1. Canopy closure in this stand type is roughly 70 percent and is comprised of 8-16" DBH trees. The dominant common canopy species include black locust and black cherry, with less common associates including poplar, red maple, green ash, black walnut, tree of heaven and white mulberry. The shrub layer in the stand is very sparse. Scattered Japanese barberry, multiflora rose and spicebush are common. Invasive exotic species cover in the shrub layer is about 40%. These stands contain a moderate vine community with about 50% cover, which includes poison ivy, grape, Japanese honeysuckle and Asiatic tear thumb.

This stand appears to be in good condition, but some invasive exotic species impact is occurring that may disrupt natural succession. There is little evidence of disease or insect damage. No significant human disturbance was noted within the stand. The habitat value of the stand is good. These stands provide good habitat for edge and field dwelling species. This stand also provides a stream buffer and a buffer for adjacent forest interior habitat. This stand contains roughly 5 acres of stream buffer and steep slopes, which are a high priority for retention. Stand F-3 should be considered a moderate priority retention area. If this forest stand is retained, the tree of heaven and white mulberry trees should be removed, to limit their spread.

Specimen Trees

Numerous specimen trees are present on the site, but the trees and their critical root zone all appear to be within the floodplain. These trees were not field located due to their position outside the net tract area.

Source: Adapted from Forest Stand Delineation prepared by Eco-Science Professionals, Inc., 2002. Used with permission.

2.3 COMBINED FOREST STAND DELINEATION AND FOREST CONSERVATION PLAN SUBMISSION

A combined Forest Stand Delineation and Forest Conservation Plan submission may be used for minor subdivisions and for grading or building permit applications on a single residential lot or parcel. Minor subdivisions of four or fewer buildable lots and single residential lots or parcels typically encompass small parcels. On-site forest resources, if any, generally lack the complexity found on larger parcels, which may have numerous stands of different composition, age, and health. The small size of the parcel, the limited extent and variety of any forest resources, and the processing of only a plot plan for a grading or building permit, or a final plan for a minor subdivision, make the procedure required for a major subdivision (a staged review and approval process of sketch, preliminary and final plan) cumbersome. Therefore, the Forest Conservation Program permits these types of development proposals to file a combined Forest Stand Delineation and Forest Conservation Plan submission.

The combined Forest Stand Delineation/Forest Conservation Plan must comply with all applicable Forest Stand Delineation and Forest Conservation Plan submittal requirements, but the information can be combined on one plan. The narrative does not have to be extensive and simple statements can be included on the plan sheet if an elaborate narrative is not needed. For additional information about Forest Conservation Plan requirements, see [Chapter 3](#). The combined Forest Stand Delineation/Forest Conservation Plan can be incorporated onto the required supplemental sheet (landscaping plan) for minor subdivisions showing existing conditions and environmental features.

CHAPTER 3: FOREST CONSERVATION PLAN

3.0 INTRODUCTION

A Forest Conservation Plan (FCP) is required for all activities subject to the Forest Conservation Program and demonstrates compliance with Program requirements. The purpose of the FCP is to provide planning and construction documents that show how Program goals will be achieved during the grading, subdivision or site development process. The plan is prepared in response to the findings of the Forest Stand Delineation described in Chapter 2 and uses those findings to make decisions about a suitable site design that will retain and protect existing forests, particularly forests in the priority retention areas described in detail later in this Chapter. While the primary goal of the Forest Conservation Program is that disturbance of existing forest resources be minimized, the Program recognizes that some clearing may be necessary to implement the land uses permitted by the zoning ordinance. The FCP also includes plans for forest planting, when such planting is necessitated by forest clearing or the absence of forest, and documents how forest retention and planting areas will be protected during and after construction.

As part of a development submission, all Forest Conservation Plans will be evaluated for compliance with specific forest conservation regulations and the overall Program goal to minimize disturbance of forest resources. The reasonableness of the proposed forest conservation measures in relation to other zoning, subdivision and design manual requirements is a prime concern. An acceptable site design will balance minimizing forest clearing with achieving reasonable use of the property, which may mean achieving less than the maximum permitted density or square footage. The Forest Conservation Plan is also reviewed to evaluate the sufficiency and the suitability of any proposed on-site reforestation or afforestation, and, if applicable, any proposed off-site retention, reforestation or afforestation. The Forest Conservation Plan must be evaluated in relation to the full range of proposed site improvements and changes to existing conditions. This Chapter explains the requirements and procedures for achieving an acceptable Forest Conservation Plan.

3.1 SUBMISSION REQUIREMENTS

A Forest Conservation Plan must show how a proposed development addresses the retention requirements and priorities of the Forest Conservation Program, how forest conservation is coordinated with other subdivision or site development requirements, whether the proposal requires any reforestation or afforestation, and if so, where and how such new planting will be done. If forest conservation obligations will be met off-site, a Forest Conservation Plan is also required for the off-site location. All design elements and construction practices must conform to the limits of disturbance and other restrictions imposed by the Forest Conservation Plan. The Forest Conservation Plan must be realistic, since later revision will require rerecording of plats and deeds, and non-compliance carries stiff penalties. For ease of review, the Forest Conservation Plan and all other related plan submissions should be at the same scale. The Forest Conservation Plan submittal shall include the following:

3.1.1 Forest Conservation Application and Forest Conservation Plan Checklist

This application form and checklist is available on the Department of Planning and Zoning web

page.

3.1.2 Forest Conservation Plan

The plan should be at the same scale and use many of the same base data sources as the associated subdivision or site development plan submission and shall use criteria or definitions as required by the Howard County Subdivision and Land Development Regulations. The plan shall show the following information required by the Forest Conservation Plan Application and Checklist, including but not limited to:

1. Base information and site features

- Boundaries of submission.
- MDE 12-digit watershed boundaries and numbers.
- Limit of disturbance lines for clearing and grading.
- Existing and proposed topography.
- Environmentally sensitive areas, including Green Infrastructure Network, critical habitat, floodplains, steep slopes, ponds, streams and their buffers, wetlands and their buffers.
- Agricultural best management practices designed to convey water above or below ground (diversions, grassed or lined waterways, irrigation systems, pipelines, subsurface drains or underground outlets).
- Boundaries of any proposed open space areas.
- Existing and proposed site improvements (roads, lots, structures, stormwater management), existing and proposed utility and access easements.

2. Forest and vegetation information

- Existing forest areas, and historic and specimen trees to be retained, including the critical root zone of each tree. Note if any forest retention areas need selective clearing and supplemental planting to address invasive exotic species.
- Existing forest areas and other trees to be cleared.
- Location and extent of any reforestation or afforestation plantings.
- Species, size and installation methods and techniques for reforestation or afforestation plantings.
- Protective measures and management techniques to maintain the environmental integrity of all forest, historic and specimen tree retention, reforestation or afforestation areas created by the plan.
- Forest Conservation Easements identified by number/letter, type and acreage. Include the length and average width of stream buffers located within these easements.
- Location of forest conservation signs.

3. Signature of the qualified professional who prepared the plan

- See Section 5.2 for the definition of a qualified professional.

4. Forest Conservation Worksheets

- Full and complete forest conservation worksheets, as shown in Appendix C, must be included on the FCP.

5. Construction period protection and management program

6. Post-construction protection and management program

3.1.3 Additional Required Documentation

Written narrative. Written justification for any clearing; any nonconformance to retention requirements and priorities, or to location priorities for reforestation or afforestation; any reforestation or afforestation methods proposed; and any proposed off-site location for retention, reforestation or afforestation.

Fee-in-lieu request form. Written request to pay a fee-in-lieu for the reforestation or afforestation obligations created by the development proposal, if applicable. Fee-in-lieu requests must demonstrate that compliance with forest conservation requirements on-site or off-site cannot be reasonably accomplished. Procedures for requesting fee-in-lieu payments are described at the end of this Chapter.

Variance request. Written request for a variance of Forest Conservation Program requirements or to defer, phase or seek alternative compliance with Forest Conservation Program requirements, if applicable. Procedures for requesting variances are given at the end of this Chapter and in Figure 5-1.

3.2 NET TRACT AREA

The net tract area is the portion of the gross site area that will be included in the forest conservation calculations. The net tract area concept is based on an assumption that floodplains, and those portions of a site that are not part of a proposed development or not undergoing any land use change are already adequately protected from disturbance, so they can be excluded from the calculations. Depending on the scope of the proposed development, the size and resubdivision potential of the property, and the extent of the anticipated land use changes, the net tract area may exclude one or more of the following.

1. **Certain areas of a site not undergoing a land use change.** The following sections explain this option for the various plan categories, where applicable.
2. **Certain right-of-way reservations and utility transmission easements.** The net tract area must always include the area of any internal or external road right-of-way dedication and must always exclude the area of any right-of-way reservation and the area within a recorded gas or electric transmission line easement.
3. **The area of a pre-existing forest conservation easement.** The area of a pre-existing forest conservation easement (FCE) must be deducted from the net tract area, unless the FCE supports on-site development from an earlier phase of the same subdivision.

The following plan categories have specific considerations for the calculation of the net tract area:

- Mixed Use, Multi-Phased Major Subdivision
- Rural Cluster Subdivision
- Minor Subdivision
- Site Development Plan
- Commercial Use on an Agricultural Property
- Linear Project

The following explanations will guide the applicant in calculating the net tract area for each of these various plan categories.

3.2.1 Mixed Use, Multi-Phased Major Subdivision

For a mixed use, multi-phased major subdivision with Preliminary Development Plan approval that is shown on a single Sketch Plan or Preliminary Equivalent Sketch Plan, and that is platting only a portion of the site at a time, the applicant may calculate the net tract area as the net acreage of the phase being processed as a Final Plan. As each subsequent phase is processed through Final Plan, the forest conservation calculations must be updated to reflect the cumulative totals, such that the calculations for the final phase are based on the net tract area of the entire site shown on the Sketch Plan or Preliminary Equivalent Sketch Plan. As each phase proceeds through the subdivision process, it must fulfill the minimum forest conservation obligation associated with the cumulative total. Forest Conservation Easements platted in an earlier phase may be credited to fulfilling the obligations associated with a later phase.

3.2.2 Rural Cluster Subdivision

A subdivision in the Rural Conservation (RC) or Rural Residential (RR) zoning district often involves large acreage, which could potentially generate large forest conservation requirements. The Forest Conservation Act provides that in rural areas the forest conservation obligations may apply only to the area of actual land use change created by a subdivision or a development proposal, not the entire original parcel.

A rural cluster subdivision often creates multiple preservation parcels, and the applicant may choose to include or exclude certain preservation parcels from the net tract area. The net tract area must always include the cluster area, any preservation parcels that are three acres or less in size, and any preservation parcels that are undergoing a land use change. For a preservation parcel containing stormwater management facilities, the creation of rain gardens, grass swales, level spreaders and similar stormwater management features will not constitute a change in use, but the creation of surface or underground sand filters, rainwater harvesting facilities and ponds will be a change in use.

The applicant may choose to include or exclude other preservation parcels from the net tract area. Including a preservation parcel may be desirable if the preservation parcel has sufficient forest resources to minimize any forest conservation obligations that development of the cluster may create. Excluding a preservation parcel may be appropriate when there are no or few existing forest resources on the site, and when including the preservation parcel would create a large afforestation obligation. This would be especially appropriate if the intent is to avoid afforestation of a preservation parcel that would be suitable for agricultural use. When calculating net tract area, each preservation parcel must be evaluated in its entirety; that is, the entire parcel must be included or excluded from calculations. The applicant is not allowed to include only a portion of a preservation parcel.

Figure 3-A provides examples to help clarify this option.

3.2.3 Minor Subdivision

For a minor subdivision in any zoning district, the applicant may exclude the residue lot or parcel from the net tract area if there is no proposed disturbance on the residue, the residue has resubdivision potential based on its current zoning designation, and there will be no change in use on the residue. The residue lot or parcel will be subject to Forest Conservation Act requirements upon future subdivision or development.

Figure 3-A
Net Tract Area Options for Cluster Subdivisions

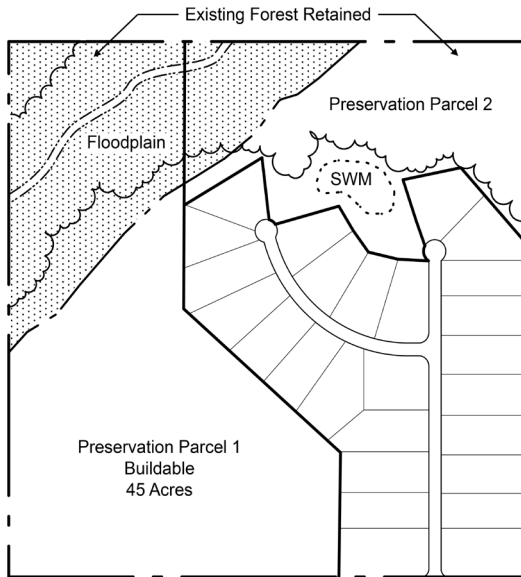

OPTION: Include or Exclude Preservation Parcel(s)

Include: If the 45-acre buildable Preservation Parcel 1 is included in the Net Tract Area (NTA), 6 acres of afforestation would be required.

Gross Site Area:	100 acres
Floodplain:	20 acres
Net Tract Area:	80 acres
Existing Forest in NTA:	10 acres
Forest Required to meet Afforestation Threshold:	16 acres
Afforestation Required:	6 acres

Exclude: If the 45-acre buildable Preservation Parcel 1 and the additional floodplain in Preservation Parcel 2 are deducted from the NTA, the NTA would be 50 acres. Planting would not be required unless existing forest is cleared.

Gross Site Area:	100 acres
Preservation Parcel 1:	45 acres
Floodplain in Pres Par 2:	5 acres
Net Tract Area:	50 acres
Existing Forest in NTA:	10 acres
Afforestation Threshold	10 acres
Reforestation Required:	0 acres

For a one-acre child or unrestricted lot release from a County Agricultural Land Preservation Easement, the applicant may exclude the remaining area of the farm from the net tract area, with the exception of any area needed for the new lot access or utilities. If this option is chosen, any portion of the farm located outside the net tract area that is used to fulfill the forest conservation obligation for the new one-acre lot will be regarded as an off-site location.

3.2.4 Site Development Plan

For a Site Development Plan (SDP) with a limit of disturbance (LOD) that is less than 40,000 square feet, the applicant may choose one of two options for calculating the net tract area:

1. The net tract area is the area within the limit of disturbance (less any applicable deductions such as the 100-year floodplain). If this option is chosen, any portion of the site located outside the LOD that is used to fulfill the forest conservation obligation for the project is to be regarded as off-site. Use of this off-site area to meet forest conservation obligations must meet the requirements described under Preferred Mitigation Location later in this Chapter. In addition, if the applicant uses this option and continues to develop the site through a series of SDPs or red-line revisions, the LOD must be tracked cumulatively on the plan. An SDP with an initial or cumulative LOD equal to or greater than 40,000 square feet must calculate the net tract area for the entire development site.
2. The net tract is the entire development site (less any applicable deductions such as the 100-year floodplain). Use of this option may be beneficial if additional development is anticipated and the applicant wishes to address all forest conservation obligations at one time.

3.2.5 Commercial Use on an Agricultural Property

When a commercial use is proposed on a property that is in agricultural use, under certain circumstances the forest conservation obligations may apply only to the area of actual land use change created by the commercial development. A commercial use may be a permitted use or a conditional use.

For a commercial use on a property encumbered with an Agricultural Land Preservation Easement (County or State, purchased or dedicated), where the limit of disturbance is equal to or greater than 40,000 square feet, the applicant may define the net tract area as the portion of the site undergoing the land use change. The area undergoing the land use change includes the area being used or established to provide access for the commercial use.

For a commercial use on a residentially zoned property used for agriculture but not encumbered by an Agricultural Land Preservation Easement, where the limit of disturbance is equal to or greater than 40,000 square feet, the applicant may define the net tract area by deducting the portion of the remainder that will continue to be devoted to agricultural uses. To qualify for this deduction, the applicant must submit written documentation from the State Department of Taxation and Assessments confirming that the property has an agricultural use and must have an approved Soil and Water Conservation Plan from the Howard Soil Conservation District.

3.2.6 Linear Project

For a linear project disturbing 20,000 square feet or more of forest, the net tract area must include the area of the road and utility right-of-way, new access roads, storage areas and the Limit of Disturbance, as shown on the Site Development Plan or Grading Plan.

3.3 CALCULATING FOREST CONSERVATION OBLIGATIONS

The objective of the Forest Conservation Plan in site planning is to maintain existing forest while protecting all priority forests and sensitive resource areas on the development site. The Forest Conservation Plan must document all proposed retention and clearing of forest resources, to determine how much reforestation and afforestation may be required. The Forest Conservation Act includes built-in incentives for retention. The reforestation thresholds are not established minimum limits for forest retention, but are instead points at which the penalty for clearing increases significantly. Conversely, any forest retained above the threshold is credited at a higher rate. This results in a clearing break even point, at which no reforestation will be required to compensate for forest clearing resulting from a proposed development.

The Forest Conservation Program establishes reforestation requirements to compensate in part for the loss of forest resources within a development and within the watershed where the development is located. Determining reforestation obligations calls for an accurate quantitative analysis of the clearing and grading impacts of a proposed development. Several variables enter into the calculation of reforestation obligations:

- Size of the net tract area.
- Amount of existing forest areas within the net tract area.
- Amount of these existing forest areas that will be retained.
- Reforestation threshold for the proposed land use.
- Extent of clearing above and below the reforestation threshold.
- Location of the planting areas (within or outside the development site watershed).

The two most significant variables are the amount of existing forest located on the net tract area of the site and the intensity of the proposed land use. When these variables are entered into the calculations, the results show whether the development will require reforestation or not, and if so, how much. If reforestation is required, the Forest Conservation Plan must show in detail where and how this will be accomplished.

Having little or no forest on-site does not exempt a development from the requirements of the Forest Conservation Program. Because the Forest Conservation Act mandates the use of forest resources to increase the environmental quality of all developing areas, proposed developments on sites without sufficient forest resources must include areas where new forest resources will be added. This afforestation is not a compensation for destroying existing resources, but an obligation to contribute to an increase in the overall forest resources of a development and of the watershed where the development is located.

It is important to understand that there is no simple minimum preservation requirement for similar land uses. The starting point is always the amount of existing forest resources in the net tract area and this varies from site to site. A proposal for an all wooded site would yield a set of calculations different from the same proposal on a site only partially wooded. The concepts and the method for calculating reforestation and afforestation requirements are rather complex; therefore, numerous examples are included in this Chapter.

3.3.1 Thresholds and Land Use

Figure 3-B lists the reforestation and afforestation thresholds for various land use categories along with applicable zoning districts. The thresholds vary with land use, being higher for low intensity uses, since it should be easier to save forest areas in very low density and low intensity developments (for example, a rural residential development) than it is in developments for more

intensive land uses (for example, a retail center). Because the threshold concept is based on land use, it does not correlate completely with zoning categories. Conditional uses, for example, may differ from the land uses normally associated with a zoning district; many institutional uses may occur in any zoning district.

The reforestation threshold is used to calculate the reforestation obligation. The reforestation thresholds cited in [Figure 3-B](#) are not minimums. Rather they specify the point at which one factor for calculating reforestation obligations shifts from a rather low ratio (1/2 to 1 acre of reforestation/1 acre cleared) to a much higher ratio (2 to 3 acres of reforestation/1 acre cleared). For reforestation sites within the same watershed as the development site, 1/2 acre of reforestation is required for every acre cleared above the threshold, and 2 acres of reforestation is required for every acre cleared below the threshold. For reforestation sites outside the development site watershed, 1 acre of reforestation is required for every acre cleared above the threshold, and 3 acres of reforestation is required for every acre cleared below the threshold.

Afforestation threshold is a much simpler concept than reforestation threshold, because it is a minimum requirement based on land use. The afforestation threshold specifies the minimum forest cover that must be present on a development site. Afforestation obligations occur only if existing forest cover is absent or if forest cover is less than the minimum required percentage of net tract area cited in [Figure 3-B](#). Clearing below the afforestation threshold results in a reforestation obligation. For reforestation sites within the same watershed as the development site, 2 acres of reforestation is required for every acre cleared below the threshold. For reforestation sites outside the development site watershed, 3 acres of reforestation is required for every acre cleared below the threshold. This reforestation requirement is added to the afforestation necessary to reach the afforestation threshold.

If an applicant will meet the forest conservation obligation partially within and partially outside the development site watershed, any planting done within the watershed will first be credited toward meeting the afforestation obligation (for sites that have one) and the remainder will be credited toward the reforestation obligation. The Forest Conservation Worksheet will adjust the forest conservation obligation that will be met outside the watershed with the higher outside the watershed mitigation ratios.

Development sites that lie within more than one watershed do not need to track forest conservation obligations by watershed. Any retention or planting within the development site will be credited as meeting forest conservation obligations within the development site watershed. If forest conservation obligations are met off-site, any retention or planting within one or more of the development site watersheds will be credited as meeting the obligation within the development site watershed.

Figure 3-B: Reforestation and Afforestation Thresholds

Land Use Category	Applicable Zoning Districts	Reforestation Threshold	Afforestation Threshold
Residential – Rural Low Density (residential lot average of 5 acres or more)	RC, RR	50%	20%
Residential – Rural Medium Density (residential lot average of 1 to 4.99 acres)	RC, RR	25%	20%
Residential – Suburban (residential lot average less than 1 acre)	R-ED, R-20, R-12, R-SC, R-SA-8, R-H-ED, R-A-15, R-APT, R-MH, R-SI, R-VH, POR, CEF-R, CCT, PSC	20%	15%
Institutional / Linear	I, POR, CCT	20%	15%
Retail / Industrial / Office	HO, HC, POR, PEC, BR, OT, CCT, B-1, B-2, SC, CEF-C, CR, M-1, M-2, SW, CE, CLI	15%	15%
Mixed Use Development / Planned Unit Development	CEF-M, NT, PGCC, MXD, TOD, CAC, TNC	20%	15%

Notes:

All rural cluster subdivisions, regardless of lot size, must use Rural Medium Density thresholds. Rural non-cluster subdivision thresholds will be based on the actual average lot size.

3.3.2 Retention Credit and Break Even Point

The system for calculating the reforestation obligations incorporates a retention credit for maintaining forest cover above the threshold figure. An applicant may deduct one acre from any reforestation obligation for each acre retained above the threshold. The credit is an incentive to clear no more than necessary, since the more forest retained above the threshold level, the less effort and money the applicant must spend locating, preparing and maintaining reforestation areas.

The retention credit provision creates a break even point for any given proposal. The break even point is the point where the credit provision offsets the reforestation obligation. The break even point is reached when credit for retaining forest above the reforestation threshold balances with the reforestation obligation incurred by the proposed clearing. Projects that meet the break even point in retention easements have met their Program obligation and do not need additional planting. The break even point for each site is based on the amount of existing forest. By saving one-third of the existing forest above the reforestation threshold within a Forest Conservation Easement, no planting obligation is required. Figure 3-C demonstrates the break even concept.

3.3.3 Sample Calculations and Illustrations

A series of sample calculations utilizing the same size site demonstrates the method for calculating thresholds and shows how varying the amount of clearing or changing the amount of original tree cover results in different reforestation or afforestation obligations. An illustration and a Forest Conservation Worksheet are provided for each example. The examples use the required Forest Conservation Worksheet found in [Appendix C](#).

[Figure 3-D](#) shows how no reforestation obligations are incurred when clearing to the break even point.

[Figure 3-E](#) shows how reforestation obligations are computed when clearing below the break even point but not below the threshold.

[Figure 3-F](#) shows how clearing below the reforestation threshold results in a substantial reforestation obligation.

[Figure 3-G](#) shows how afforestation obligations are incurred on a site with little existing forest.

[Figure 3-H](#) shows how clearing forest areas on a site that does not meet the minimum afforestation requirement creates a reforestation and an afforestation obligation.

[Figure 3-I](#) shows how reforestation obligations are calculated when a portion of the reforestation obligation will be met outside the development site watershed.

[Figure 3-J](#) shows how reforestation obligations are calculated when a portion of the afforestation obligation will be met outside the development site watershed.

3.4 PREFERRED MITIGATION LOCATION

The preferred method for meeting forest conservation requirements is through on-site forest retention and planting. However, retaining existing stands or creating new forest resources within a development may not always be practical or result in significant forest communities. Therefore, it may be necessary or more environmentally beneficial to fulfill forest conservation requirements through other means or at another Howard County location.

The following is the preferred sequence for location of retention, reforestation and afforestation:

1. **On-site.** Fulfill forest conservation obligations by retention, reforestation or afforestation within the same development that creates the obligation.
2. **Mitigation bank.** Mitigation banks are retained or planted forest conservation areas that are established for the purpose of providing credits for forest mitigation requirements.
3. **Off-site.** Off-site retention or planting is established to meet forest conservation obligations for a specific development.

An additional preference is to choose mitigation banks or off-site locations that are within the development site watershed. Choosing locations outside the development site watershed will increase forest conservation obligations.

**Figure 3-C
Break Even Point**

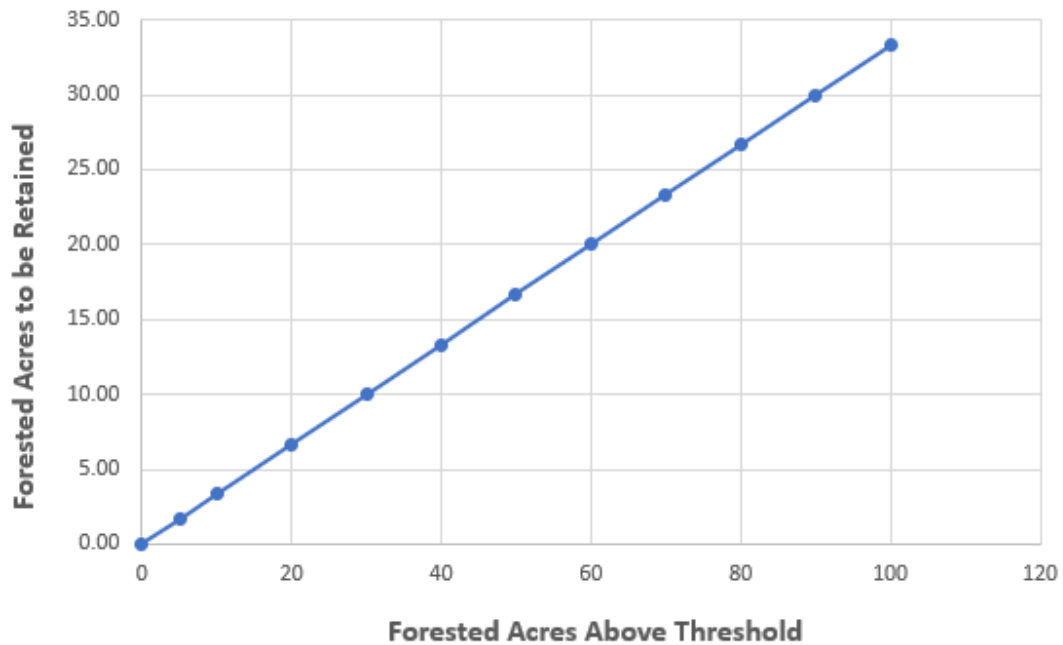

Notes:

1. A simple relationship exists between the number of forested acres above the reforestation threshold and the amount of this forest that must be retained to be exempt from reforestation requirements (the Break Even Point).
2. One acre of retention is required for every 3 acres of forest above the reforestation threshold (1:3 = 33%).
3. The dashed line above illustrates how to calculate the break even point.
4. Figures 3-D through 3-F demonstrate the application of this calculation for three sample projects.

Figure 3-D Clearing to the Break Even Point

FOREST CONSERVATION WORKSHEET FOR _____

Net Tract Area

A. Total (Gross) Tract Area	A = <u>110.0</u>
B. Area within 100-year Floodplain	B = <u>10.0</u>
C. Other Deductions (Identify: _____)	C = <u>0.0</u>
D. Net Tract Area	D = <u>100.0</u>

Land Use Category

Insert the number "1" under the appropriate land use (limit to only one entry)

Resid. Rural LD	Resid. Rural MD	Resid. Suburban	Inst./ Linear	Retail/Ind./ Office	Mixed Use/ PUD
0	0	1	0	0	0

E. Afforestation Threshold (Net Tract Area x 15%)	E = <u>15.0</u>
F. Reforestation Threshold (Net Tract Area x 20%)	F = <u>20.0</u>

Existing Forest Cover

G. Existing Forest Cover within the Net Tract Area	G = <u>75.0</u>
H. Area of Forest above Afforestation Threshold	H = <u>60.0</u>
I. Area of Forest above Reforestation Threshold	I = <u>55.0</u>

Break Even Point

J. Break Even Point	J = <u>38.3</u>
K. Forest Clearing Permitted without Mitigation	K = <u>36.7</u>

Proposed Forest Clearing

L. Total Area of Forest to be Cleared	L = <u>36.7</u>
M. Total Area of Forest to be Retained	M = <u>38.3</u>

Planting Requirements Inside Watershed

N. Reforestation for Clearing above the Reforestation Threshold	N = <u>18.4</u>
P. Reforestation for Clearing below the Reforestation Threshold	P = <u>0.0</u>
Q. Credit for Retention above the Reforestation Threshold	Q = <u>18.4</u>
R. Total Reforestation Required	R = <u>0.0</u>
S. Total Afforestation Required	S = <u>0.0</u>
T. Total Reforestation and Afforestation Requirement	T = <u>0.0</u>
U. 75% of Total Obligation (Retention + Planting)	U = <u>28.7</u>
V. Planting Required Onsite to meet 75% Obligation	V = <u>0.0</u>

Planting Requirements Outside Watershed

W. Total Planting within Development Site Watershed	W = <u>0.0</u>
X. Total Afforestation Required	X = <u>0.0</u>
Y. Remaining Planting within Watershed for Reforestation Credit	Y = <u>0.0</u>
Z. Reforestation for Clearing above the Reforestation Threshold	Z = <u>0.0</u>
AA. Reforestation for Clearing below the Reforestation Threshold	AA = <u>0.0</u>
BB. Credit for Retention above the Reforestation Threshold	BB = <u>0.0</u>
CC. Total Reforestation Required	CC = <u>0.0</u>
DD. Total Afforestation and Reforestation Requirement	DD = <u>0.0</u>

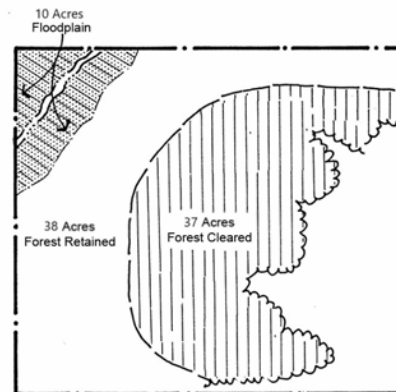
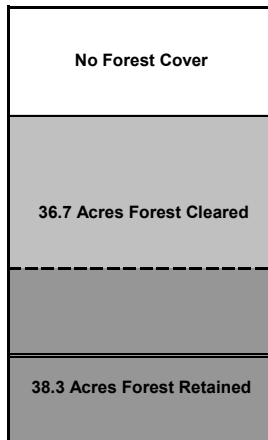

Figure 3-E Clearing below the Break Even Point

FOREST CONSERVATION WORKSHEET FOR _____

Net Tract Area

A. Total (Gross) Tract Area	A =	110.0
B. Area within 100-year Floodplain	B =	10.0
C. Other Deductions (Identify: _____)	C =	0.0
D. Net Tract Area	D =	100.0

Land Use Category

Insert the number "1" under the appropriate land use (limit to only one entry)

Resid. Rural LD	Resid. Rural MD	Resid. Suburban	Inst./ Linear	Retail/Ind./ Office	Mixed Use/ PUD
0	0	1	0	0	0

E. Afforestation Threshold	(Net Tract Area x 15%)	E =	15.0
F. Reforestation Threshold	(Net Tract Area x 20%)	F =	20.0

Existing Forest Cover

G. Existing Forest Cover within the Net Tract Area	G =	80.0
H. Area of Forest above Afforestation Threshold	H =	65.0
I. Area of Forest above Reforestation Threshold	I =	60.0

Break Even Point

J. Break Even Point	J =	40.0
K. Forest Clearing Permitted without Mitigation	K =	40.0

Proposed Forest Clearing

L. Total Area of Forest to be Cleared	L =	50.0
M. Total Area of Forest to be Retained	M =	30.0

Planting Requirements Inside Watershed

N. Reforestation for Clearing above the Reforestation Threshold	N =	25.0
P. Reforestation for Clearing below the Reforestation Threshold	P =	0.0
Q. Credit for Retention above the Reforestation Threshold	Q =	10.0
R. Total Reforestation Required	R =	15.0
S. Total Afforestation Required	S =	0.0
T. Total Reforestation and Afforestation Requirement	T =	15.0
U. 75% of Total Obligation (Retention + Planting)	U =	33.8
V. Planting Required Onsite to meet 75% Obligation	V =	3.8

Planting Requirements Outside Watershed

W. Total Planting within Development Site Watershed	W =	15.0
X. Total Afforestation Required	X =	0.0
Y. Remaining Planting within Watershed for Reforestation Credit	Y =	15.0
Z. Reforestation for Clearing above the Reforestation Threshold	Z =	0.0
AA. Reforestation for Clearing below the Reforestation Threshold	AA =	0.0
BB. Credit for Retention above the Reforestation Threshold	BB =	0.0
CC. Total Reforestation Required	CC =	0.0
DD. Total Afforestation and Reforestation Requirement	DD =	0.0

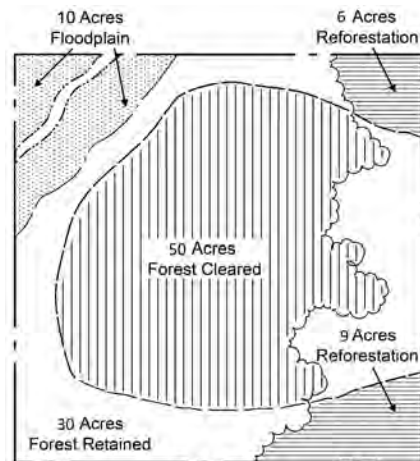
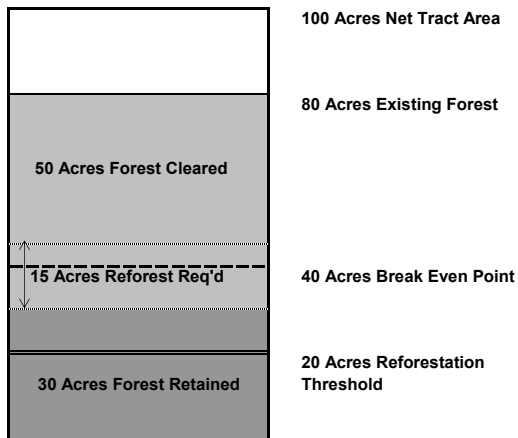

Figure 3-F Clearing below the Reforestation Threshold

FOREST CONSERVATION WORKSHEET FOR _____

Net Tract Area

A. Total (Gross) Tract Area	A =	110.0
B. Area within 100-year Floodplain	B =	10.0
C. Other Deductions (Identify: _____)	C =	0.0
D. Net Tract Area	D =	100.0

Land Use Category

Insert the number "1" under the appropriate land use (limit to only one entry)

Resid. Rural LD	Resid. Rural MD	Resid. Suburban	Inst./ Linear	Retail/Ind./ Office	Mixed Use/ PUD
0	0	1	0	0	0

E. Afforestation Threshold	(Net Tract Area x 15%)	E =	15.0
F. Reforestation Threshold	(Net Tract Area x 20%)	F =	20.0

Existing Forest Cover

G. Existing Forest Cover within the Net Tract Area	G =	60.0
H. Area of Forest above Afforestation Threshold	H =	45.0
I. Area of Forest above Reforestation Threshold	I =	40.0

Break Even Point

J. Break Even Point	J =	33.3
K. Forest Clearing Permitted without Mitigation	K =	26.7

Proposed Forest Clearing

L. Total Area of Forest to be Cleared	L =	45.0
M. Total Area of Forest to be Retained	M =	15.0

Planting Requirements Inside Watershed

N. Reforestation for Clearing above the Reforestation Threshold	N =	20.0
P. Reforestation for Clearing below the Reforestation Threshold	P =	10.0
Q. Credit for Retention above the Reforestation Threshold	Q =	0.0
R. Total Reforestation Required	R =	30.0
S. Total Afforestation Required	S =	0.0
T. Total Reforestation and Afforestation Requirement	T =	30.0
U. 75% of Total Obligation (Retention + Planting)	U =	33.8
V. Planting Required Onsite to meet 75% Obligation	V =	18.8

Planting Requirements Outside Watershed

W. Total Planting within Development Site Watershed	W =	30.0
X. Total Afforestation Required	X =	0.0
Y. Remaining Planting within Watershed for Reforestation Credit	Y =	30.0
Z. Reforestation for Clearing above the Reforestation Threshold	Z =	0.0
AA. Reforestation for Clearing below the Reforestation Threshold	AA =	0.0
BB. Credit for Retention above the Reforestation Threshold	BB =	0.0
CC. Total Reforestation Required	CC =	0.0
DD. Total Afforestation and Reforestation Requirement	DD =	0.0

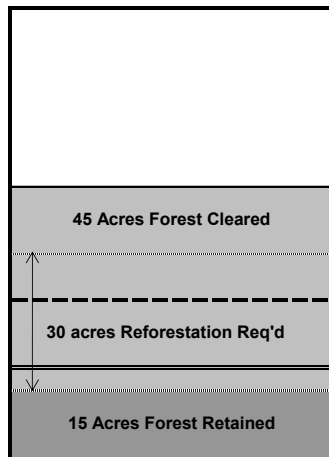

100 Acres Net Tract Area

60 Acres Existing Forest

33 Acres Break Even Point

20 Acres Reforestation Threshold

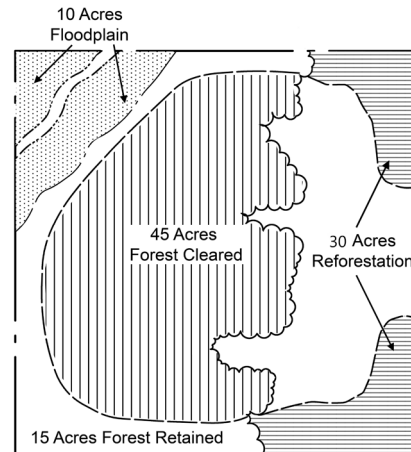

Figure 3-G Meeting the Afforestation Threshold

FOREST CONSERVATION WORKSHEET FOR _____

Net Tract Area

A. Total (Gross) Tract Area	A =	110.0
B. Area within 100-year Floodplain	B =	10.0
C. Other Deductions (Identify: _____)	C =	0.0
D. Net Tract Area	D =	100.0

Land Use Category

Insert the number "1" under the appropriate land use (limit to only one entry)

Resid. Rural LD	Resid. Rural MD	Resid. Suburban	Inst./ Linear	Retail/Ind./ Office	Mixed Use/ PUD
0	0	1	0	0	0

E. Afforestation Threshold	(Net Tract Area x 15%)	E =	15.0
F. Reforestation Threshold	(Net Tract Area x 20%)	F =	20.0

Existing Forest Cover

G. Existing Forest Cover within the Net Tract Area	G =	10.0
H. Area of Forest above Afforestation Threshold	H =	0.0
I. Area of Forest above Reforestation Threshold	I =	0.0

Break Even Point

J. Break Even Point	J =	0.0
K. Forest Clearing Permitted without Mitigation	K =	0.0

Proposed Forest Clearing

L. Total Area of Forest to be Cleared	L =	0.0
M. Total Area of Forest to be Retained	M =	10.0

Planting Requirements Inside Watershed

N. Reforestation for Clearing above the Reforestation Threshold	N =	0.0
P. Reforestation for Clearing below the Reforestation Threshold	P =	0.0
Q. Credit for Retention above the Reforestation Threshold	Q =	0.0
R. Total Reforestation Required	R =	0.0
S. Total Afforestation Required	S =	5.0
T. Total Reforestation and Afforestation Requirement	T =	5.0
U. 75% of Total Obligation (Retention + Planting)	U =	11.3
V. Planting Required Onsite to meet 75% Obligation	V =	1.3

Planting Requirements Outside Watershed

W. Total Planting within Development Site Watershed	W =	5.0
X. Total Afforestation Required	X =	0.0
Y. Remaining Planting within Watershed for Reforestation Credit	Y =	0.0
Z. Reforestation for Clearing above the Reforestation Threshold	Z =	0.0
AA. Reforestation for Clearing below the Reforestation Threshold	AA =	0.0
BB. Credit for Retention above the Reforestation Threshold	BB =	0.0
CC. Total Reforestation Required	CC =	0.0
DD. Total Afforestation and Reforestation Requirement	DD =	0.0



100 Acres Net Tract Area

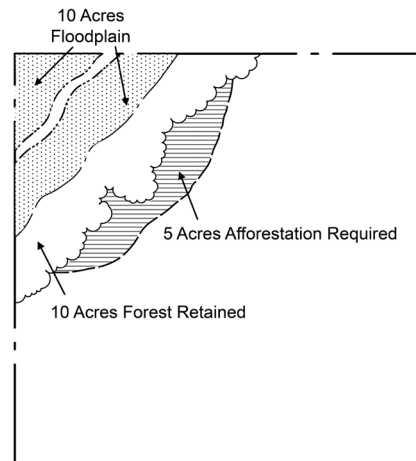

Figure 3-H Clearing below the Afforestation Threshold

FOREST CONSERVATION WORKSHEET FOR _____

Net Tract Area

A. Total (Gross) Tract Area	A =	110.0
B. Area within 100-year Floodplain	B =	10.0
C. Other Deductions (Identify: _____)	C =	0.0
D. Net Tract Area	D =	100.0

Land Use Category

Insert the number "1" under the appropriate land use (limit to only one entry)

Resid. Rural LD	Resid. Rural MD	Resid. Suburban	Inst./ Linear	Retail/Ind./ Office	Mixed Use/ PUD
0	0	1	0	0	0

E. Afforestation Threshold	(Net Tract Area x 15%)	E =	15.0
F. Reforestation Threshold	(Net Tract Area x 20%)	F =	20.0

Existing Forest Cover

G. Existing Forest Cover within the Net Tract Area	G =	10.0
H. Area of Forest above Afforestation Threshold	H =	0.0
I. Area of Forest above Reforestation Threshold	I =	0.0

Break Even Point

J. Break Even Point	J =	0.0
K. Forest Clearing Permitted without Mitigation	K =	0.0

Proposed Forest Clearing

L. Total Area of Forest to be Cleared	L =	5.0
M. Total Area of Forest to be Retained	M =	5.0

Planting Requirements Inside Watershed

N. Reforestation for Clearing above the Reforestation Threshold	N =	0.0
P. Reforestation for Clearing below the Reforestation Threshold	P =	10.0
Q. Credit for Retention above the Reforestation Threshold	Q =	0.0
R. Total Reforestation Required	R =	10.0
S. Total Afforestation Required	S =	5.0
T. Total Reforestation and Afforestation Requirement	T =	15.0
U. 75% of Total Obligation (Retention + Planting)	U =	15.0
V. Planting Required Onsite to meet 75% Obligation	V =	10.0

Planting Requirements Outside Watershed

W. Total Planting within Development Site Watershed	W =	15.0
X. Total Afforestation Required	X =	0.0
Y. Remaining Planting within Watershed for Reforestation Credit	Y =	10.0
Z. Reforestation for Clearing above the Reforestation Threshold	Z =	0.0
AA. Reforestation for Clearing below the Reforestation Threshold	AA =	0.0
BB. Credit for Retention above the Reforestation Threshold	BB =	0.0
CC. Total Reforestation Required	CC =	0.0
DD. Total Afforestation and Reforestation Requirement	DD =	0.0

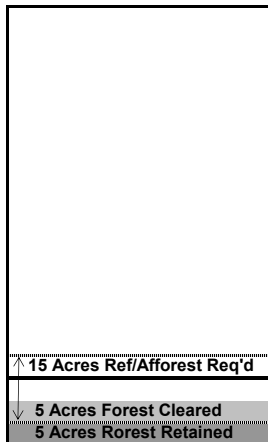

100 Acres Net Tract Area

15 Acres Afforestation Threshold
10 Acres Existing Forest

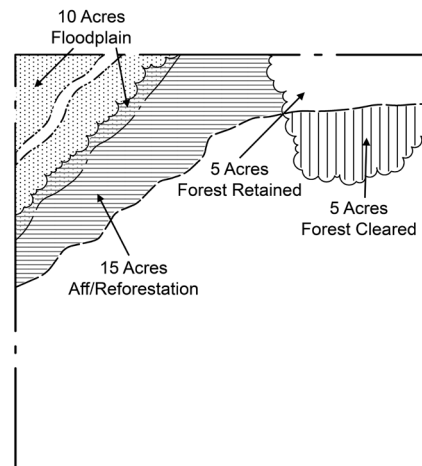

Figure 3-1 Clearing Below the Reforestation Threshold with Planting Outside the Watershed

FOREST CONSERVATION WORKSHEET FOR _____

Net Tract Area

A. Total (Gross) Tract Area	A =	110.0
B. Area within 100-year Floodplain	B =	10.0
C. Other Deductions (Identify: _____)	C =	0.0
D. Net Tract Area	D =	100.0

Land Use Category

Insert the number "1" under the appropriate land use (limit to only one entry)

Resid. Rural LD	Resid. Rural MD	Resid. Suburban	Inst./ Linear	Retail/Ind./ Office	Mixed Use/ PUD
0	0	1	0	0	0

E. Afforestation Threshold (Net Tract Area x 15%)	E =	15.0
F. Reforestation Threshold (Net Tract Area x 20%)	F =	20.0

Existing Forest Cover

G. Existing Forest Cover within the Net Tract Area	G =	60.0
H. Area of Forest above Afforestation Threshold	H =	45.0
I. Area of Forest above Reforestation Threshold	I =	40.0

Break Even Point

J. Break Even Point	J =	33.3
K. Forest Clearing Permitted without Mitigation	K =	26.7

Proposed Forest Clearing

L. Total Area of Forest to be Cleared	L =	45.0
M. Total Area of Forest to be Retained	M =	15.0

Planting Requirements Inside Watershed

N. Reforestation for Clearing above the Reforestation Threshold	N =	20.0
P. Reforestation for Clearing below the Reforestation Threshold	P =	10.0
Q. Credit for Retention above the Reforestation Threshold	Q =	0.0
R. Total Reforestation Required	R =	30.0
S. Total Afforestation Required	S =	0.0
T. Total Reforestation and Afforestation Requirement	T =	30.0
U. 75% of Total Obligation (Retention + Planting)	U =	33.8
V. Planting Required Onsite to meet 75% Obligation	V =	18.8

Planting Requirements Outside Watershed

W. Total Planting within Development Site Watershed	W =	20.0
X. Total Afforestation Required	X =	0.0
Y. Remaining Planting within Watershed for Reforestation Credit	Y =	20.0
Z. Reforestation for Clearing above the Reforestation Threshold	Z =	0.0
AA. Reforestation for Clearing below the Reforestation Threshold	AA =	15.0
BB. Credit for Retention above the Reforestation Threshold	BB =	0.0
CC. Total Reforestation Required	CC =	15.0
DD. Total Afforestation and Reforestation Requirement	DD =	15.0

This project has a reforestation obligation of 30 acres for clearing above and below the reforestation threshold. The 20 acres of reforestation within the watershed will meet the 20-acre obligation for clearing above the reforestation threshold. The obligation for clearing below the reforestation threshold is recalculated using the outside the watershed mitigation ratio to generate a new reforestation for clearing below the threshold obligation of 15 acres.

Figure 3-J Clearing Below the Afforestation Threshold with Planting Outside the Watershed

FOREST CONSERVATION WORKSHEET FOR _____

Net Tract Area

A. Total (Gross) Tract Area	A =	110.0
B. Area within 100-year Floodplain	B =	10.0
C. Other Deductions (Identify: _____)	C =	0.0
D. Net Tract Area	D =	100.0

Land Use Category

Insert the number "1" under the appropriate land use (limit to only one entry)

Resid. Rural LD	Resid. Rural MD	Resid. Suburban	Inst./ Linear	Retail/Ind./ Office	Mixed Use/ PUD
0	0	1	0	0	0

E. Afforestation Threshold (Net Tract Area x 15%)	E =	15.0
F. Reforestation Threshold (Net Tract Area x 20%)	F =	20.0

Existing Forest Cover

G. Existing Forest Cover within the Net Tract Area	G =	10.0
H. Area of Forest above Afforestation Threshold	H =	0.0
I. Area of Forest above Reforestation Threshold	I =	0.0

Break Even Point

J. Break Even Point	J =	0.0
K. Forest Clearing Permitted without Mitigation	K =	0.0

Proposed Forest Clearing

L. Total Area of Forest to be Cleared	L =	5.0
M. Total Area of Forest to be Retained	M =	5.0

Planting Requirements Inside Watershed

N. Reforestation for Clearing above the Reforestation Threshold	N =	0.0
P. Reforestation for Clearing below the Reforestation Threshold	P =	10.0
Q. Credit for Retention above the Reforestation Threshold	Q =	0.0
R. Total Reforestation Required	R =	10.0
S. Total Afforestation Required	S =	5.0
T. Total Reforestation and Afforestation Requirement	T =	15.0
U. 75% of Total Obligation (Retention + Planting)	U =	15.0
V. Planting Required Onsite to meet 75% Obligation	V =	10.0

Planting Requirements Outside Watershed

W. Total Planting within Development Site Watershed	W =	10.0
X. Total Afforestation Required	X =	0.0
Y. Remaining Planting within Watershed for Reforestation Credit	Y =	5.0
Z. Reforestation for Clearing above the Reforestation Threshold	Z =	0.0
AA. Reforestation for Clearing below the Reforestation Threshold	AA =	7.5
BB. Credit for Retention above the Reforestation Threshold	BB =	0.0
CC. Total Reforestation Required	CC =	7.5
DD. Total Afforestation and Reforestation Requirement	DD =	7.5

This project has an afforestation obligation of 5 acres and a reforestation obligation of 10 acres for clearing below the afforestation threshold. The 10 acres of planting within the watershed will meet the 5-acre afforestation obligation, with the remaining 5 acres going toward the reforestation obligation. The remaining obligation for clearing below the threshold is recalculated using the outside the watershed mitigation ratio to generate a new reforestation for clearing below the threshold obligation of 7.5 acres.

3.4.1 Meeting Obligations in Mitigation Banks and Off-site Locations

Only if no reasonable on-site locations are available, will the purchase of credits in mitigation banks or planting/retention in off-site locations be approved. Off-site mitigation may occur when the County determines that on-site retention, reforestation or afforestation is inappropriate, for example, where reforestation or afforestation would result in stands that would be small, ecologically isolated or in low priority locations. Before the purchase of credits in mitigation banks or off-site compliance will be considered, the applicant must meet the site design requirements specified later in this Chapter under 3.7.4 Coordination with Site Design.

The applicant must demonstrate to the satisfaction of the Department of Planning and Zoning that on-site planting is impractical or will be of much less environmental value than the purchase of credits at a mitigation bank, or retention or planting at an off-site location. Mitigation banks or off-site retention or planting can be more environmentally valuable than planting on-site when it will:

- Expand or create tree cover in environmentally sensitive areas.
- Expand large forest stands already protected by a Forest Conservation Easement or other conservation easement.
- Enhance permanently protected open space or preservation parcels through planting.
- Fulfill small (under 10,000 s. f.) obligations by being pooled with other such obligations, rather than creating isolated, low value forest stands.
- Retain trees in high priority locations on properties that are potentially developable (that is, not dedicated open space or subject to preservation easements of any kind).

Locations for mitigation banks and off-site retention or planting should preferably be within the same MDE 12-digit watershed (see Figure 3-K for map) as the development that generated the forest conservation requirements. If the development site lies within more than one watershed, the bank or off-site location may be located in any of the development site watersheds. If the applicant demonstrates that this is not feasible, the Department of Planning and Zoning will approve the use of mitigation banks or off-site locations in another Howard County watershed, but the forest conservation obligation will increase. It shall be the applicant's responsibility to propose an appropriate mitigation bank or off-site location. The County will maintain an inventory of approved forest mitigation banks.

Ratios and criteria for meeting retention and planting obligations in mitigation banks and off-site locations vary, thus more detail is provided below. In particular, special requirements apply to locations in the Rural West on preservation parcels and agricultural preservation easements. Chapter 5 provides more information about establishing forest mitigation banks, and about buying and selling credits in mitigation banks.

3.4.2 Forest Mitigation Banks

Forest mitigation banks are encouraged as a means of addressing forest conservation obligations. Mitigation banks can be created as forest retention or forest planting areas, providing a mechanism for protecting existing forests or creating large forest plantings in high priority locations. Banks must be a minimum of one acre in size and generally create or protect larger areas of forest than is done under off-site retention or planting. Therefore, the purchase of credits from mitigation banks is preferred over individual off-site retention or planting locations.

Mitigation banks must be established in the priority locations identified in this Manual for forest retention and planting, and must be protected by a Forest Conservation Easement. After a bank

has been approved, developers may purchase mitigation credits when the Department of Planning and Zoning determines that forest conservation obligations can be met through a bank.

3.4.3 Retention Mitigation Banks and Off-Site Retention

Purchased credits from a retention mitigation bank and off-site retention, when approved by the Department of Planning and Zoning, must occur at a ratio of 2 acres of retained forest for every 1 acre of forest planting obligation. Retention banks and off-site retention may only be established on property with development potential. Therefore, open space, preservation parcels and sites encumbered by preservation easements are not suitable for this use. However, retention easements may be placed in high priority areas on a County agricultural land preservation easement to meet the forest conservation obligation generated by a child or unrestricted lot release. In addition, a retention easement may be placed on a preservation parcel or a site with a preservation easement, if it is done at the same time that the preservation easement is recorded.

For a rural cluster subdivision, minor subdivision or Site Development Plan where a portion of the site was excluded from the net tract area, forest retention credit can be taken on the excluded portion of the site. However, because this portion was excluded from the net tract area, this must be regarded as off-site retention and the retention must be provided at a 2 to 1 ratio for the forest conservation obligation.

3.4.4 Planted Mitigation Banks and Off-Site Planting

Purchased credits from a planted mitigation bank and off-site planting within the development site watershed, when approved by the Department of Planning and Zoning (DPZ), must be equivalent in area to the forest conservation obligation that would otherwise have occurred on-site. Purchased credits from a planted mitigation bank and off-site planting outside the development site watershed, must be equivalent in area to the forest conservation obligation that would otherwise have occurred on-site, as increased by outside the watershed mitigation ratios. Planted banks and off-site planting may be established on any property deemed suitable by DPZ and may include sites in the (Columbia) New Town zoning district.

For properties protected by a County Agricultural Land Preservation Easement, planted banks and off-site planting will be allowed only in the following areas in compliance with the County Forest Conservation Planting Policy, so as not to displace active agricultural functions:

- Stream buffers - a maximum of 100 feet on either side of the stream bank.
- Wetlands and wetland buffers - a maximum of 50 feet from the edge of the wetland.
- Slopes - 25% or greater.
- Howard County Green Infrastructure Network.

For properties protected by a Maryland Agricultural Land Preservation Foundation (MALPF) Easement, the requirements for a planted Forest Conservation Easement overlay are given in COMAR 15.15.13, including:

- The planting area may not exceed 10 acres or 10% of the easement area, whichever is less, unless MALPF determines otherwise.
- The development project for which the planting is providing mitigation must be located within the Priority Funding Area, except for MALPF approved lot releases on the same MALPF easement.

Figure 3-K
Forest Conservation Watersheds Map

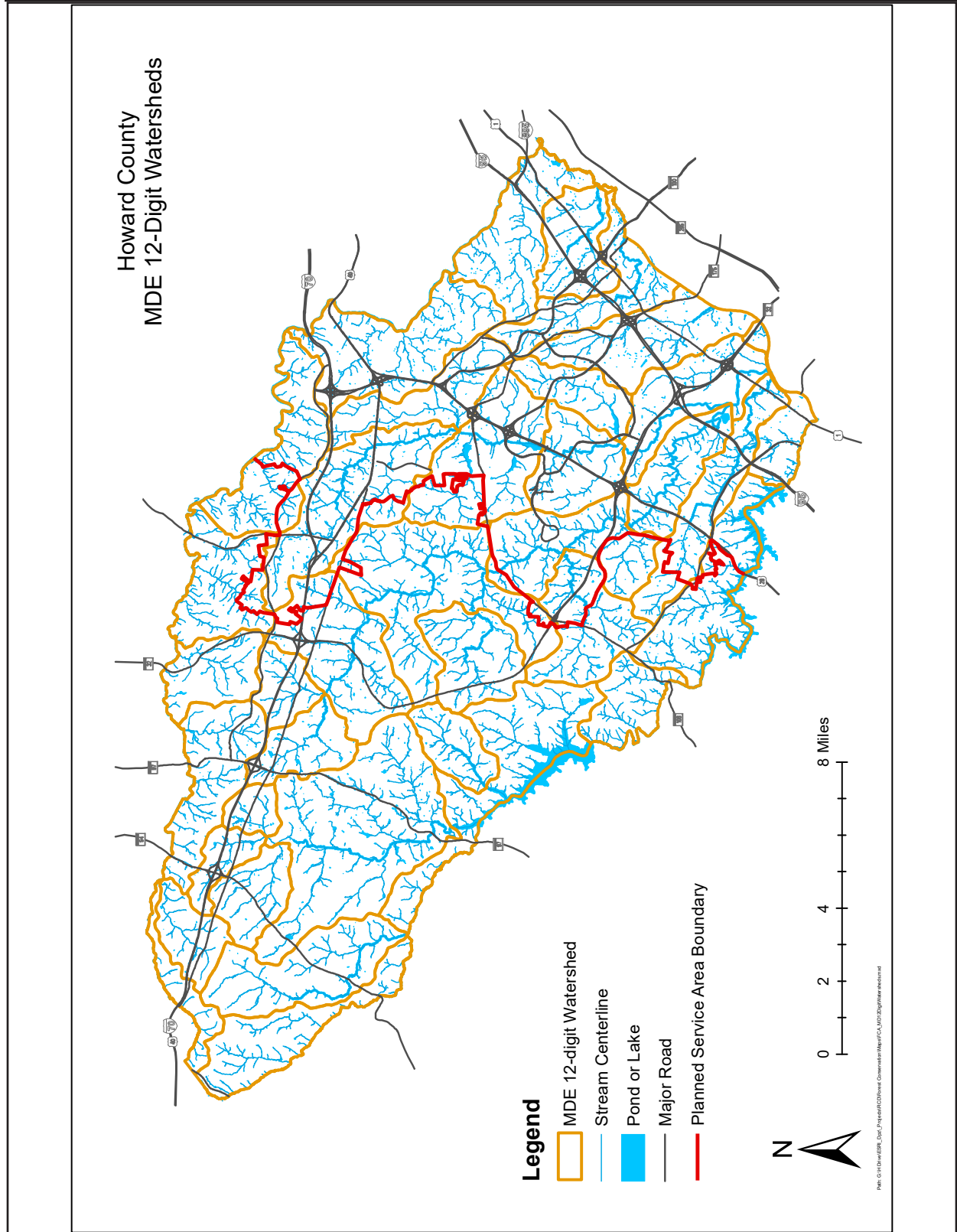

Any banking and off-site planting proposals, including any exceptions to the above list, involving properties with Howard County Agricultural Land Preservation Easements must be reviewed and approved by the Agricultural Land Preservation Program Administrator and the Agricultural Preservation Board for compatibility with the recorded Agricultural Land Preservation Easement and the County Forest Conservation Planting Policy. Any banking and off-site planting proposals, including any exceptions to the above list, involving properties with Maryland Agricultural Land Preservation Foundation Easements must be reviewed by the Agricultural Land Preservation Program Administrator, recommended by the Agricultural Preservation Board for compatibility with COMAR 15.15.13, and reviewed and approved by MALPF.

3.4.5 Landowner Agreement

A mitigation bank and off-site planting or retention require that the applicant have a legal right to use the proposed site. The owner of the mitigation bank or off-site property must agree to the required long-term use restrictions on the retention or planting areas, and must be a party to the Deed of Forest Conservation Easement and plat that will establish the Forest Conservation Easement. In addition, consideration must be given to the future development plans for the site. The encumbrance of all or a portion of the site with a Forest Conservation Easement may impact its development potential.

3.4.6 Coordination with Density Calculations

The area of a pre-existing forest conservation easement must be deducted from the gross site area for the following density calculations, except that a FCE does not need to be deducted from a receiving parcel if it supports on-site development from an earlier phase of the same subdivision.

- Density Exchange Option/Cluster Exchange Option sending site.
- Base density calculations for a standard rural cluster subdivision.
- Base density calculations for a density receiving rural cluster subdivision.

3.5 FOREST RETENTION AREAS

The Forest Conservation Plan must depict all existing forest areas to be retained as part of the development proposal. The size of the retained forest areas is measured, at a minimum, to the nearest 1/10 acre. The Forest Conservation Plan must specify limits of disturbance that ensure the designated forest retention areas will remain undisturbed. Retention areas will be restricted use areas protected by Forest Conservation Easements, and no credit will be given for forest retention areas not protected by Forest Conservation Easements.

Existing forests may sometimes contain non-native trees and other woody plants. However, if existing forest to be retained has areas dominated by invasive exotic trees and other woody vegetation, this vegetation must be removed and the area replanted with native trees to establish a healthy, native forest. Credit can be given for the replanting through the selective clearing and supplemental planting option, but this credit must be established during the development review process, prior to approval of the Forest Conservation Plan. The areas dominated by invasive exotic species must be delineated and described in the Forest Stand Delineation and the methods to treat and replant the areas must be given in the Forest Conservation Plan. If the invasive species are discovered after the Forest Conservation Plan has been approved, then the invasive species must be removed and the area replanted with native trees without a replanting credit.

The forest retention areas must be kept intact; violations will result in enforcement actions, mitigation penalties or both. To avoid future use conflicts, forest retention areas should preferably be located in open space lots or rural cluster preservation parcels. Location of forest retention on lots for private residential use is only permitted in accordance with the lot usability requirements set forth in Section 16.120(b)(4)(iii) of the Subdivision and Land Development Regulations, which state that forest conservation easements may only be located on a lot or buildable preservation parcel of ten acres or greater, if the building envelope is no closer than 35 feet from the easement, provided that a deck may project ten feet beyond the building envelope. Retention easements must not be placed on septic reserve areas, since these areas will be cleared if needed for septic disposal. Retention easements must not include underground or overhead utility lines or easements, since these areas may need to be cleared or trimmed for utility maintenance.

3.5.1 Priority Forest Retention Areas

Although all forest stands have environmental value, priority areas for retention must be established for development sites. Some clearing is often unavoidable to permit the land uses allowed by zoning. The basic intent of the Forest Conservation Program is to keep any forest losses to a minimum. When choices must be made, however, the Program favors protecting forest stands that help protect sensitive areas such as floodplains, wetlands, steep slopes and streams. The emphasis of the Program is on protecting sensitive areas and on maintaining large, contiguous, undisturbed forest stands.

The trees, shrubs and plants listed below are a priority for retention and must be left undisturbed. Areas containing these resources should be located in open space or preservation parcels to ensure their ongoing protection.

1. **Rare, threatened and endangered species.** Retain and protect trees, shrubs and other vegetation identified on the Federal and State rare, threatened and endangered species list (available from the Maryland Department of Natural Resources).
2. **Trees that are part of an historic site or associated with an historic structure.** An historic site is any site or structure listed on the Howard County Historic Sites Inventory. An historic structure or cluster of structures have significant historic or architectural value and have been designated as such by resolution of the County Council. Note that according to Title 16, Subtitle 6 of the Howard County Code, prior to the initial submittal of a development plan on a site located in a historic district, adjoining a multi-site historic district or that contains a historic structure, applicants must request review by the Historic Preservation Commission to identify all historic resources on the site and obtain advice from the Commission regarding the design of development.
3. **Specimen trees.** State Champion trees, trees 75% or more of the diameter of the State Champion tree for that same species, and trees 30" in diameter or larger. A list of State Champion Trees is available on the DPZ website.

The areas listed below are given in order of priority for forest retention. They should be left undisturbed unless the applicant can demonstrate to the Department of Planning and Zoning that reasonable efforts to protect them cannot be implemented, that the uses allowed by right cannot occur without such disturbance, or that forest planting in an alternate location would have greater environmental benefit. In any case, all requirements regarding preservation of 100-year floodplains, steep slopes, streams and their buffers, and wetlands and their buffers will be

enforced as required by other sections of the County regulations. The Forest Conservation Plan will be evaluated in part for how effective it is in protecting the priority forest retention areas.

1. **Howard County Green Infrastructure Network.** This mapped system of hubs and corridors within the County delineates important habitat areas, including large, contiguous tracts of forests and wetlands.
2. **100-year floodplain.** Forested floodplains, when included in the net tract area, must be protected for their water storage, water quality and habitat values.
3. **Stream buffers.** To protect stream water quality and habitat, the County requires a 75' or 100' undisturbed buffer for perennial streams in residential zoning districts, and a 50' buffer for perennial streams in nonresidential zoning districts and for intermittent streams in all zoning districts. Stream buffer requirements are described more fully in Section 16.116 of the Subdivision and Land Development Regulations.
4. **Wetlands and wetland buffers.** Retaining forest cover in or near wetland areas is of high priority, as these areas provide water storage and water quality values, and are key wildlife habitats. The County requires a 25' undisturbed buffer for wetlands.
5. **Critical habitats and wildlife corridors.** Retaining critical habitat areas and forest corridors with a minimum width of 300 feet for wildlife movement is highly desirable.
6. **Steep slopes.** Forests protect steep topography from eroding, thus forest should be protected on steep slopes 25% and greater, and slopes of 15% or greater with a soil erodibility factor (K) greater than 0.35. Existing County regulations protect steep slope areas (25% or greater) which are at least 20,000 square feet, or which are adjacent to streams or wetlands, from disturbance.
7. **Forest contiguous with sensitive areas.** Forests adjacent to the sensitive areas listed above – Green Infrastructure Network, floodplains, streams and their buffers, wetlands and their buffers, and steep slopes - provide increased protection for these valued resource areas and expand habitat areas.
8. **Forest contiguous with protected off-site forests.** Protecting forests that are contiguous to existing forest protected by a Forest Conservation Easement may expand potential wildlife corridors and forest interior habitats.
9. **Property line and right-of-way buffers.** Forests in these areas, particularly adjacent to scenic roads, are highly valued for their ability to screen incompatible uses, provide privacy and enhance the scenic character of the landscape. Such locations as public road setback areas, the edge between residential and nonresidential land uses, or the demarcation of rural housing clusters from active farm operations are especially suitable for protection.

3.5.2 Forest Retention Area Size

The minimum size of any forest retention area shall be 10,000 square feet (about 1/4 of an acre) with a minimum width of 35 feet. This is an absolute minimum width, not an average width. Smaller wooded areas should be saved for the aesthetic value they provide to a development, particularly when these areas include specimen trees, significant trees associated with historic

sites, or property line or right-of way buffers adjacent to scenic roads. However, such areas will not be considered forest conservation areas, except as follows:

- When such wooded areas are adjacent to a forested 100-year floodplain that has been excluded from the net tract area of the site. In these cases, both the forest within the floodplain and adjacent to the floodplain must be placed within a Forest Conservation Easement, and the easement must have a combined minimum area of 10,000 square feet with a minimum width of 35 feet. Since the floodplain was excluded from the net tract area, however, only the forest outside the floodplain will be considered as a credited retention easement.
- When such wooded areas are adjacent to off-site forest protected by a Forest Conservation Easement, or located on County or State parkland. If the combined area of the on-site and off-site forest meets the minimum size of 10,000 square feet and minimum width of 35 feet, the on-site forest will be considered as a credited retention easement.
- When such wooded areas are in priority retention areas and will be enlarged by reforestation or afforestation to the minimum size of 10,000 square feet and minimum width of 50 feet. In these cases, the existing forest will not be credited as a retention area, but will be credited toward the reforestation or afforestation obligation.

3.6 REFORESTATION AND AFFORESTATION AREAS

When reforestation or afforestation obligations occur, the Forest Conservation Plan must locate appropriate areas for planting new forest cover. Such new forest cover should be located where it can most effectively advance the environmental goals of the Forest Conservation Program and will be most likely to thrive. The minimum size of any planting area shall be 10,000 square feet (about 1/4 of an acre) with a minimum width of 50 feet. This is an absolute minimum width, not an average width. Smaller planting areas may only be allowed if they are adjacent to existing forest protected with a forest conservation easement and the combined areas meet the minimum planting size requirements.

The size of the area, the initial appearance of such plantings, and their relative fragility when compared to retained mature forest areas make locations relatively isolated from the more intensively used areas of a development more appropriate than areas such as private yards, entry points or along street rights-of-way. For these reasons, the best location for new plantings is within open space. Locating new forest plantings in open space makes proper long-term management and enforcement of use restrictions easier. Forest planting on lots for residential use is permitted only in accordance with Section 16.120(b)(4)(iii) of the Subdivision and Land Development Regulations, which states that forest conservation easements may only be located on a lot or buildable preservation parcel of ten acres or greater, if the building envelope is no closer than 35 feet from the easement, provided that a deck may project ten feet beyond the building envelope.

3.6.1 Priority Reforestation and Afforestation Areas

Similar to priority areas for retention of existing forest resources, the Program also cites priority areas for reforestation and afforestation. The most appropriate locations for these new forest plantings are where they will protect, enhance or restore environmentally sensitive areas within the proposed development. The Department of Planning and Zoning may approve lower priority

locations for reforestation and afforestation on this list when such locations better achieve the intent of the Program or County land use regulations. If off-site planting would have greater environmental benefit, the Department of Planning and Zoning may approve planting in high priority off-site locations. The priority sequence for selecting reforestation or afforestation sites follows.

- 1. Howard County Green Infrastructure Network.** Planting or enhancing forest cover within the hubs and corridors of the network is a high priority. The network defines and links the most ecologically valuable habitat in the County and the majority of hubs contain large blocks of interior forest. Expanding these forested hubs and widening the forested corridors that connect them will increase the network's habitat value.
- 2. 100-year floodplains and stream bank buffers.** Planting within 100-year floodplain areas may be used to fulfill reforestation or afforestation obligations if this will not compromise the ability of the floodplain to act as a natural storage and floodway system, and if appropriate plant materials are selected. The County requires a 75' or 100' undisturbed buffer for perennial streams in residential zoning districts, and a 50' buffer for perennial streams in nonresidential zoning districts and for intermittent streams in all zoning districts. These buffer areas may presently not have full forest cover. Using reforestation or afforestation obligations to increase or to create new forest cover along streams is a priority. There may be additional requirements for planting along streams in nonresidential zoning districts, as discussed in the following section on Coordination with Site Design.
- 3. Wetlands and wetland buffers.** Providing forest cover in or near wetland areas is of high priority. Wetlands are key wildlife habitats and creating additional natural cover can increase this habitat value. However, such planting should be done only when it will not have a negative impact on the existing wetland resources and where forest cover would normally be the natural cover. Converting scrub shrub or emergent wetlands to forested wetlands is generally discouraged.
- 4. Critical habitats and buffers to create forest corridors for wildlife movement.** Critical habitats contribute to the long-term protection of threatened or endangered species. The use of reforestation or afforestation to expand critical habitat and the surrounding protection area is highly desirable. By expanding existing forests to a minimum width of 300', corridors for wildlife movement can be created and enhanced.
- 5. Steep slope areas.** Forest cover is the best check on soil erosion, especially as the topography gets steeper. Existing County regulations protect steep slope areas (25% or greater) which are at least 20,000 square feet, or which are adjacent to streams or wetlands. If these areas are not forested, they should be candidates for reforestation or afforestation. Areas somewhat less steep (15% - 25%) should also be planted, especially if located on highly erodible soils (K value greater than 0.35). Built slopes of 25% or greater, such as noise berms or entrance features, are not a priority for forest conservation planting, because these areas often have compacted soils. These built slopes should be planted with landscape plants, particularly for entrance features, as homeowners often prefer a manicured look with landscaping and mowed lawn for these areas.
- 6. Areas adjacent to existing forest stands.** Adding to existing forest stands outside the sensitive areas listed above also creates valued environmental resource areas,

especially when high quality existing forests can be protected or enhanced by planting similar species. Expanding existing forests increases their habitat value and provides air and water quality benefits.

7. **Infill between isolated forest stands and groves of specimen trees.** Reforestation or afforestation can be used to create a larger forest entity by closing the gaps between small forest areas or remnants of former forest areas. In this way, areas that had aesthetic value but little environmental value may be greatly enhanced and, in time, become true forest communities.
8. **Property line or right-of-way buffers.** As long as these areas are at least 50' wide and meet the minimum size criteria, such plantings can meet reforestation or afforestation obligations. Such locations as public road setback areas, the edge between residential and nonresidential land uses, or the demarcation of rural housing clusters from active farm operations may be suitable for new forest plantings. Plantings should be set back from property lines to minimize interference with adjacent properties from future tree growth.

3.7 COORDINATION WITH OTHER SITE ISSUES

The placement of Forest Conservation Easements on a site must be coordinated with other site design requirements and the presence of other easements. The following offers information about coordination with wetland mitigation requirements, BGE and PEPCO, Conservation Reserve Enhancement Program areas, and site design requirements. If other easements exist or will exist in an area proposed for a Forest Conservation Easement, the applicant should consult with the Department of Planning and Zoning regarding coordination between easements.

3.7.1 Coordination with Wetland Mitigation Requirements

Obligations for wetland mitigation to compensate for disturbing wetlands or wetland buffers shall be calculated separately at ratios specified by Federal or State regulations for such disturbances. These obligations must be met and Forest Conservation Program requirements do not in any way nullify or supersede wetland mitigation requirements. Forested wetland mitigation plantings may not be used to fulfill reforestation or afforestation obligations.

3.7.2 Coordination with BGE and PEPCO

The following guidelines should be used for forest conservation retention or planting near BGE power lines or rights-of-way. Forest retention easements must be located at least 45 feet from a BGE power line or from the edge of a BGE transmission right-of-way. Existing forest located closer than 45 feet may remain, but will not be credited as forest retention. Planted forest conservation easements must be located at least 20 feet from a BGE power line or from the edge of a BGE transmission right-of-way. Forest species planted in the easement between 20 and 45 feet from the power line or right-of-way must be species that will have a maximum mature height of 40 feet.

If BGE or PEPCO power lines, easements or rights-of-way are present on or immediately adjacent to a development site, the applicant must contact BGE or PEPCO, as applicable, and receive written approval for the proposed forest conservation retention or planting areas in the vicinity of the power lines, easements or rights-of-way. DPZ will not grant plan approval until BGE or PEPCO has issued their written approval. Contact information for BGE and PEPCO is

available on the DPZ web page.

3.7.3 Coordination with Agricultural Best Management Practices

Agricultural properties may have best management practices designed to convey water above or below ground, such as diversions, grassed or lined waterways, irrigation systems, pipelines, subsurface drains, or underground outlets. If these practices are to remain, they should not be designated as forest planting areas and some practices may require planting area setbacks to protect the practice.

Agricultural properties may have forested stream buffers that were planted under the Federal Conservation Reserve Enhancement Program (CREP). Under the CREP contract, the landowner is required to plant and maintain the trees for a specified number of years (usually 10 to 15 years). Existing and proposed CREP areas cannot be used as off-site mitigation areas or banks during the term of the CREP contract, but may qualify as forest retention areas after the contract has ended if they meet the definition of a forest as cited in this Manual.

For more information about agricultural best management practices and/or CREP restrictions, contact the District Manager at the Howard Soil Conservation District.

3.7.4 Coordination with Site Design

Site design should address the Forest Conservation Program goals of maximizing forest retention and meeting forest conservation obligations on-site. Before mitigation banks, off-site compliance or fee-in-lieu requests will be considered, applicants must meet their forest conservation obligations on-site, in accordance with the following site design requirements.

Nonresidential developments and mixed use or planned unit developments that are greater than 50% nonresidential, based on gross square footage of use, must accommodate forest conservation obligations on-site by, at a minimum, establishing Forest Conservation Easements with retained or planted forest in all sensitive areas, including floodplains, wetlands, wetland buffers, steep slopes and stream buffers. To ensure protection of riparian areas, the Forest Conservation Easements must be a minimum 75-foot width from the banks of any perennial and intermittent stream. If necessary, the area outside the required stream buffer and within the Forest Conservation Easement may be disturbed during construction and then reforested.

Residential developments and mixed use or planned unit developments that are greater than 50% residential development, based on gross square footage of use, with more than one acre of obligation, must meet a minimum of 75% of their obligation on-site by reducing lot sizes, clustering lots or units, and maximizing open space to the maximum extent permitted by the Subdivision and Land Development Regulations. Infill subdivisions of ten or fewer lots or units are excluded from this requirement. Infill subdivisions are residential developments within the Planned Service Area that create one or more units on a property that adjoins an existing residential unit. Residential developments, such as apartment buildings or condominiums, that have ten or fewer lots, but more than ten units are subject to this requirement.

Residential developments in the RC and RR zoning districts that propose to import density must accommodate all forest conservation obligations within the boundaries of the receiving property before they will be permitted to import development density. This may impact receiving density.

Residential developments for detached or attached dwelling units must provide a 35-foot setback from rear and side residential lot lines and any on-site or off-site planted Forest Conservation Easement, to limit encroachments into the easement (see [Figure 3-L](#)). The setback may be eliminated if larger stock (two rows of one-inch minimum caliper) is planted along the edge of the Forest Conservation Easement. If an applicant is planting larger stock on-site adjacent to an off-site easement, the combined easement areas must meet current minimum size and width requirements. Plantings should be set back from property lines to minimize interference with adjacent properties from future tree growth.

3.8 PREFERRED METHODS FOR REFORESTATION AND AFFORESTATION

The Forest Conservation Plan must also select the most appropriate method to accomplish the required planting. A variety of planting options are available to meet the specific opportunities or limitations of any given development proposal. The following is the preferred sequence of reforestation and afforestation methods:

1. Planting with nursery stock.
2. Transplanting local plant material.
3. Natural regeneration.
4. Selective clearing and supplemental planting.

The choice of methods and plant materials should be related to the specific location within the proposed development and the physical characteristics of this location. The following sections describe specific examples of when each of these options are appropriate, provide design guidance, and identify the manner in which the planting must be implemented so that the chosen method may be judged suitable to meet reforestation or afforestation obligations.

Forests contain more than just trees, so applicants are encouraged to go beyond this guidance to speed the establishment of true forest communities. For example, if forest clearing occurs on site, rootwads and other coarse woody debris from this clearing may be placed strategically throughout the new planting areas to replicate large woody debris habitat. The debris should not be pushed up in piles. This addition to the planting areas will benefit forest establishment and improve habitat.

3.8.1 Planting with Nursery Stock

Planting with nursery stock is the most commonly used option for reforestation and afforestation. Of primary concern is the hardiness of the nursery stock for the climate and conditions of the planting site. For this reason, there is a preference for stock sourced and grown in the region.

Requirements for Approval

- Species native to Maryland shall be used. Local, native genetic stock is recommended for better survivability.
- Species must be suitable for planting site conditions.
- Stock must meet American Association of Nurserymen specifications.

**Figure 3-L
Residential Lot Line Setbacks from Easements**

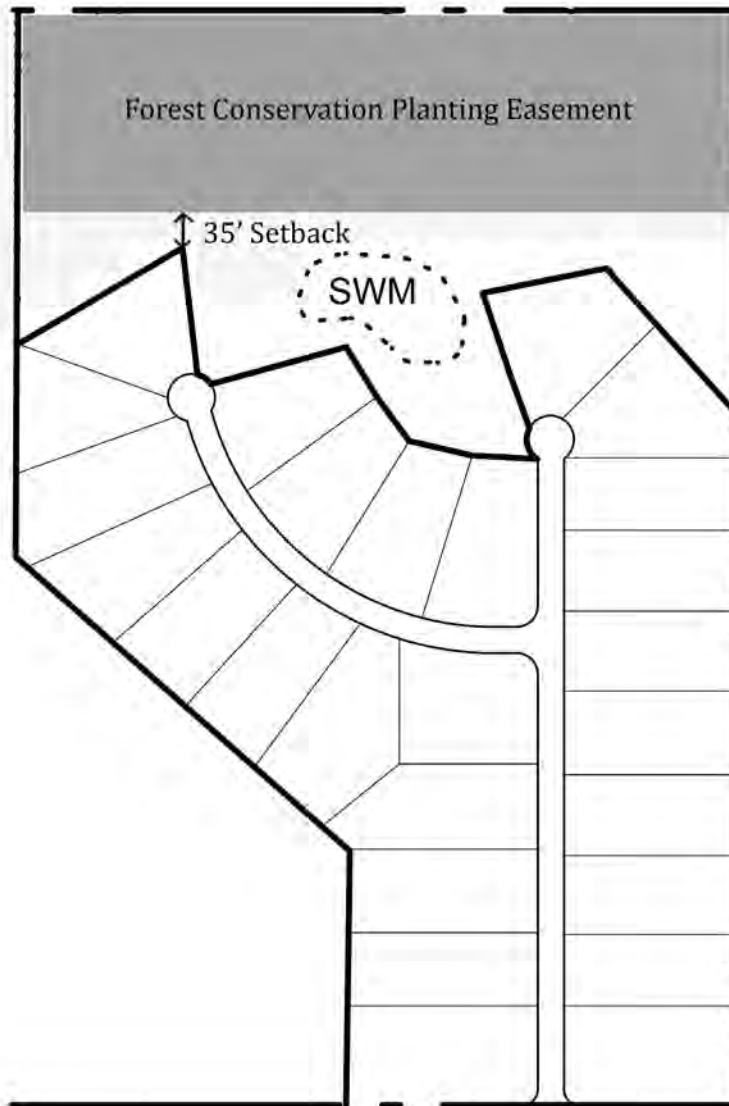

This residential development for detached dwelling units must provide a 35-foot setback from rear and side lot lines and the planted Forest Conservation Easement, to limit encroachments into the easement. This setback may be eliminated if larger stock (two rows of one-inch minimum caliper) is planted along the edge of the Forest Conservation Easement.

3.8.2 Transplanting Local Plant Materials

The use of transplanted materials is generally approved due to the hardiness and adaptability of local plant materials to local conditions. The risks associated with this practice derive from the methods used for transplanting, storing and planting transplanted materials, and the soil characteristics of the planting site.

Design Guidance

- Mid to late successional species, in general, are less tolerant of transplanting than early successional species.
- Larger trees (more than 6" caliper) need specialized care and equipment. Investigative root diggings are recommended for larger trees.
- Best time for transfer is late autumn (after leaf fall) or early winter.
- Transplants are not recommended in spring after the buds start to grow.
- Soft rooted species with frozen root ball are not recommended for transplant.
- Open grown trees grown in heavy or clay soils are preferred for transplant, because their rooting patterns are typically denser than forest grown trees.

Requirements for Approval

- Plant material must be species native to Maryland.
- The material to be transplanted must be amenable to disturbance.
- The plant material must be suited for the reforestation site (sunlight, soils, moisture regime).
- Soils must be prepared in a planting field fashion, with proper soil amendments.
- Root balls must meet or exceed American Association of Nurserymen specifications.
- If plant material is stored on- or off-site in tree banks, the location, treatment and schedule for banking and transplant must be described.

3.8.3 Natural Regeneration

Under natural conditions, the lands of this region have remarkable long-term abilities to regenerate forests, but numerous variables affect the success of this process. Natural regeneration is appropriate when the planting site has areas with relatively undisturbed soils that are prepared and managed to encourage the regeneration of forests through natural recruitment by seed bank, standing seed crop or asexual sprouting. Natural regeneration is appropriate for areas such as abandoned fields where natural regeneration has already successfully begun and native, early successional tree species have been established. Areas that are graded or otherwise disturbed as part of the proposed development may be suitable for reforestation or afforestation, but not natural regeneration. When an area is disturbed, compaction may occur, weed seeds may be released and germinate, and native plant seed sources may be destroyed, thus inhibiting regeneration of natural forests and creating conditions suitable for the introduction of invasive exotic plants. Because of the difficulties in assessing long-term survival rates and size criteria, the post-construction guarantee periods may be required to exceed the three-growing season minimum specified for other techniques.

Design Guidance

- Best used in low visibility, low use areas or on areas that are hard to manage (such as extremely steep slopes).
- Treatment is extremely species and site specific; therefore, it is recommended that a licensed forester prepare the management plan and supplemental planting plan.

- Management and monitoring of these areas should be intensive, given concerns about invasive exotic plants and impacts from deer.

Requirements for Approval

- At least 75% of the proposed planting area must be located within 50 feet of an adjoining forest or the proposed planting area must be a forest opening less than one acre, and the adjoining forest must have less than 20% cover of invasive exotic species.
- Native, early successional trees must exist in sufficient numbers to meet the 700 seedlings per acre standard for forest by the end of the three growing season post-construction period.
- Plan must provide detailed information on the method of regeneration and the forest association being targeted for the site.
- Construction equipment must be prohibited from this area, through site signage and fencing. Information about these techniques must be shown on the plan.
- If using soil seed bank for regeneration, the original seed bed, or other local suitable seed source must not be disturbed.
- Soils must be stabilized with an appropriate cover material (non-turf building).
- The post-construction management program must remove and control noxious weeds, invasive species and non-native tree species.
- Supplemental planting may be used to bring the area up to standards.
- Post-construction management must extend until minimum height and survival standards can be achieved, or supplemental planting may be required to bring the area up to standards.

3.8.4 Selective Clearing and Supplemental Planting

Selective clearing and supplemental planting is a priority when existing forest resources can be conserved and enhanced, particularly when existing forest resources are threatened or dominated by invasive exotic species, or potential forest communities can be created from existing tree stands that do not meet the definition of forest. Selective clearing and supplemental planting may be appropriate under the following conditions:

- When used to expand and/or stabilize the edges of forest retention areas disturbed by clearing and construction activities such as grading or installation of infrastructure.
- When used as infill planting of open areas within existing forests that have little or no canopy cover, or that have insufficient number of trees on a per acre basis.
- When used for selective removal of dead, diseased or physically damaged trees and replanting those disturbed areas so that distressed areas within existing forests can be restored to a healthy forest ecology.
- When used to transform stands of mature trees without understory into true forest stands by supplemental planting of understory trees and shade tolerant trees that could grow into canopy trees.
- When used to transform stands of trees that are dominated by invasive exotic trees and other woody plants into native forest stands by removing invasive exotic species and replacing them with native trees.

All areas improved or enhanced by selective clearing and supplemental planting will be given reforestation or afforestation credit, as long as the work results in areas meeting the quantitative standards defining forest.

Design Guidance

- Grade sensitive species may need to be removed if subjected to significant grade changes within their critical root zone.
- If sun-sensitive species are abundant on the stand margin, supplemental planting of sun-tolerant plant materials is recommended or these sun-sensitive species should be removed.
- Species prone to wind-throw (for example, Virginia Pine) within 1 tree height of existing or proposed structures should be removed.
- Snags may be left for the benefit of wildlife if they pose no safety hazards.

Requirements for Approval

- Existing forest and proposed supplemental plantings must meet the minimum standards for a forest.
- Proposed supplemental plantings are suitable for specific site conditions; species selected are appropriate match to existing plant community.
- Proposed supplemental planting stock must be species native to Maryland and local native genetic stock is recommended for better survivability.
- Selective clearing will remove existing or potential future nuisances (for example, species sensitive to disturbance or stress, invasive exotic plants).
- Selective clearing will enable young regenerative population to grow more quickly into a mature forest environment.
- Applicant must show selective clearing and supplemental planting will result in true forest communities.
- Selective clearing and supplemental planting objectives must be clearly defined in the reforestation plan. Selective clearing is not acceptable for purely aesthetic reasons.
- Specific trees targeted for removal or alteration as part of a selective clearing program must be noted on plans.
- Selective clearing must not disturb the remaining trees and understory.
- Stumps should not be removed under any circumstance.
- Selectively cleared areas must be planted with supplemental plant materials in accordance with the forest planting standards of this Manual.
- Non-native plant debris, trash and large piles of dumped natural debris must be removed from the area.

3.9 REFORESTATION AND AFFORESTATION PLANTING PLANS

The reforestation or afforestation plan should be included on the same plan sheet that depicts the forest retention areas, although a planting plan and specifications may be submitted as a separate plan sheet when this will make review easier. Preservation of trees and landscaping not covered by the Forest Conservation Program can be included on the Forest Conservation Plan sheet(s) to show how such efforts can be coordinated with forest conservation requirements.

Any reforestation or afforestation proposals shall include a planting plan and plant materials table which depict in detail:

- Plant genus and species.
- Number of plants and spacing.

- Size and condition of plants.
- Plant installation techniques.

Developing a planting plan requires three steps: 1) Assess the existing and proposed conditions of the proposed planting site; 2) Choose an appropriate mix of plant materials and site preparation methods for the site conditions; and 3) Specify methods and density of planting.

3.9.1 Site Assessment

The priorities cited earlier in this Chapter should be followed when selecting reforestation or afforestation locations, but other factors must also be considered in selecting locations, plant species, and proper site preparation and planting techniques. Past and proposed uses may dictate special treatments and limitations for the reforestation and afforestation sites. For example, uses that compact soils may call for intensive soil disking prior to planting. A soil compaction test is recommended and may need to be conducted after construction is completed, especially if the proposed planting area will include built slopes. Soils that have been actively farmed within the past several years may need to be evaluated for residual pesticides or herbicides. Sites that are dominated by invasive exotic species will need control measures, and these measures should start as early as possible before planting to ensure success. See [Chapter 4](#) for more information about site preparation techniques.

A soil analysis is recommended, and an assessment of soil moisture should also be made at this time. Use soil survey information on depth to water table, geotechnical information from soil borings, and knowledge of proposed grade and drainage divide changes to determine likely moisture regimes of the proposed site. The soil survey will also provide guidance on the degree of soil productivity (as measured in height) for common tree species, seedling mortality, and ability to use equipment to prepare and plant tree stands.

Future uses of adjacent land can also influence the choice of the reforestation and afforestation sites. For example, planting adjacent to future high use areas may need larger plant stock to insure survivability. Special attention should be given to aesthetic considerations for areas immediately adjacent to buildings or roads.

3.9.2 Plant Selection

Plant selection should seek to integrate native forest associations into the proposed development. Forest associations typically found in this region are listed in [Appendix D](#). [Appendix D](#) also contains a list of native tree species. Species native to Maryland must be used. Local genetic stock is recommended because of hardiness and disease resistance.

Two options for selecting the mix of plant species are suggested. The first is to evaluate the adjacent or nearby undisturbed forest stands and attempt to replicate these forest communities, if site conditions permit. The second option is to use the map and plant lists in [Appendix D](#) as a guide to plant selection. Material on forest associations in this Appendix is from: The natural forests of Maryland: an explanation of the vegetation map of Maryland (with 1:250,000 map) by G. S. Brush, C. Lenk and J. Smith, 1980, Ecological Monographs 50:77-92. The map identifies five major forest associations in the County and lists the common or characteristic plants found in each of the associations.

Natural forests are complex, multi-species, multi-layered systems. New forest plantings, therefore, should include a minimum of five different tree species, unless part of a landscaping plan or other forest planting plan approved by the County. The mix of species should be as

follows to encourage quick tree growth and canopy closure, which can help minimize impacts from invasive species and deer browse:

Successional Stage

- Approximately two-thirds early successional species.
- One-third mid or late successional species.

Place in canopy

- 75% overstory trees.
- 25% understory trees.

3.9.3 Plant Material Size, Density and Arrangement

Figure 3-M presents the required density, size and spacing for reforestation and afforestation plant materials. Note that shrubs may not be planted, because they are too susceptible to damage from deer.

Figure 3-M: Plant Quantity, Size, Spacing and Equivalent Area

Number trees/acre	Size	Spacing (feet)	Equivalent area/tree (sq ft)
100	2-inch caliper	20 x 20	435.6
200	1-inch caliper	15 x 15	217.8
300	2- to 3-gallon container grown, 4 to 5 feet tall, typically a 2-year plant	12 x 12	145.2
400	1-gallon container grown, 1 to 4 feet tall, typically a 1-year plant	10 x 10	108.9
350	Whips	11 x 11	124.5
700	Seedlings	8 x 8	62.2

Due to the high deer population in Howard County, tree shelters or cages are required for all planting stock.

Nursery grown or transplanted plant materials should meet or exceed the requirements of American Standard for Nursery Stock specifications. That is, the plants should be typical of the species and variety, have a normal habit of growth, be first quality, sound, vigorous, well-branched, have healthy, well-furnished root systems, and be free of disease, insect pests and mechanical injuries.

Seedlings or whips will only be permitted for the creation of mitigation banks, on steep slope planting areas or in other locations as approved by the Department of Planning and Zoning.

Whips should meet the following standards:

- An unbranched woody plant greater than 24 inches in height and having a diameter of less than 1 inch measured at 2 inches above the root collar.

Seedlings should meet the following standards:

- An unbranched woody plant less than 24 inches in height and having a diameter of less than ½ inch measured at 2 inches above the root collar with roots 8 inches or longer.

The spacings identified above are not meant to imply that trees must be planted in a grid

pattern. A more natural appearance is desired. Planting in clusters and/or curvilinear rows to facilitate access for maintenance is permitted. See [Figure 3-N](#) for possible planting patterns.

Planting a mixture of stock sizes is recommended. The following guidelines should be considered:

- Larger stock may be more successful near structures, in areas of high human activity or where the deer population is large.
- Include larger stock deciduous and evergreen trees where providing an attractive edge or buffer for nearby residents is of concern or where the view from nearby roads is an issue.
- Use larger material to screen smaller stock (which may be considered less attractive) when reforestation or afforestation occurs in more publicly visible areas. The use of larger material may also help fulfill landscaping obligations.
- Use smaller stock for understory trees and larger stock for overstory in a random planting.
- Smaller stock may be acceptable when plantings will be away from heavy use areas or where not aesthetically objectionable (for example, away from roads and houses).

When planting a mix of stock sizes, the equivalent area/tree given in [Figure 3-M](#) can be used to confirm the number of trees planted meets the number of trees per acre requirements. For example, planting 100 1-inch caliper trees with 200 1-gallon trees in one acre will give an equivalent area of $100 \times 217.8 + 200 \times 108.9 = 43,560$ sq ft = 1 acre, which meets planting requirements.

A credit may be granted towards reforestation/afforestation obligations for landscape size material planted to meet perimeter buffer requirements. However, the accounting methods for landscaping and forest conservation are different. Landscaping is based on linear feet, while forest conservation is based on square feet. To calculate the forest conservation credit, plants installed as landscaping must be converted to square feet, based on the following conversion rates:

- 2.5-inch caliper shade tree = 400 square feet.
- 8- to 10-foot high ornamental or 6- to 8-foot high evergreen tree = 225 square feet.

[Chapter 4](#) contains installation descriptions for each category of plant material. Planting specifications on the Forest Conservation Plan need to take into consideration how the planting area is to be prepared and maintained. Control of noxious weeds, competing vegetation and deer need to be addressed. If difficult access will limit maintenance activities, it may be desirable to increase the amount of material planted in order to meet survival rates. The three growing season survival rate for afforestation and reforestation areas shall be a minimum of 100 trees per acre or at least 75% of the total number of trees planted per acre under the approved plan, whichever is greater.

Figure 3-N Planting Patterns

Typical Forest Tree Distribution Patterns

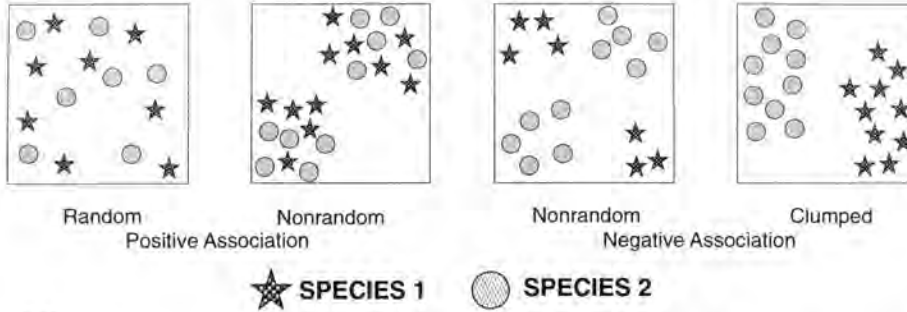

Note: Naturally occurring populations of trees tend to be found in informal groupings. A cluster of trees is really a mosaic of different species groups. The objective of an afforestation/reforestation plan is to select the appropriate species and distribution pattern for a chosen site that mimic natural patterns.

Source: Prince Georges County Woodland Conservation Manual.

Aggregate Distribution Drift

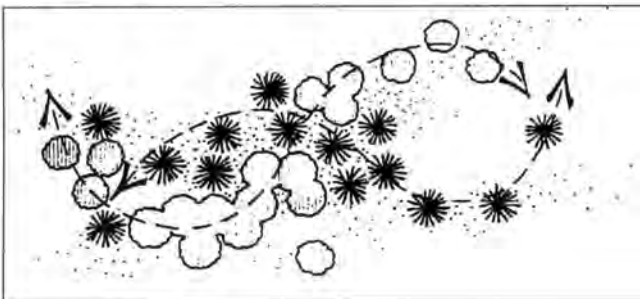

Note: When used, plant cluster type groupings that taper or feather out along the edges. Clusters often appear as elongated or tear drop shapes.

Source: EQR, Inc.

Mixing Transplant Stock

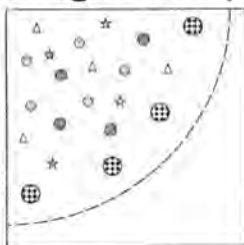

- ⊕ Locate larger trees (B&B or container grown) or transplant stock at the perimeter of reforestation/afforestation plantings of whips, seedling grown stock.
- Protective Fencing
- *△ Smaller Stock

Source: Adapted from Forest Conservation Manual, 1991

Figure 3-N
Planting Patterns (continued)

Curvilinear Randomized Planting

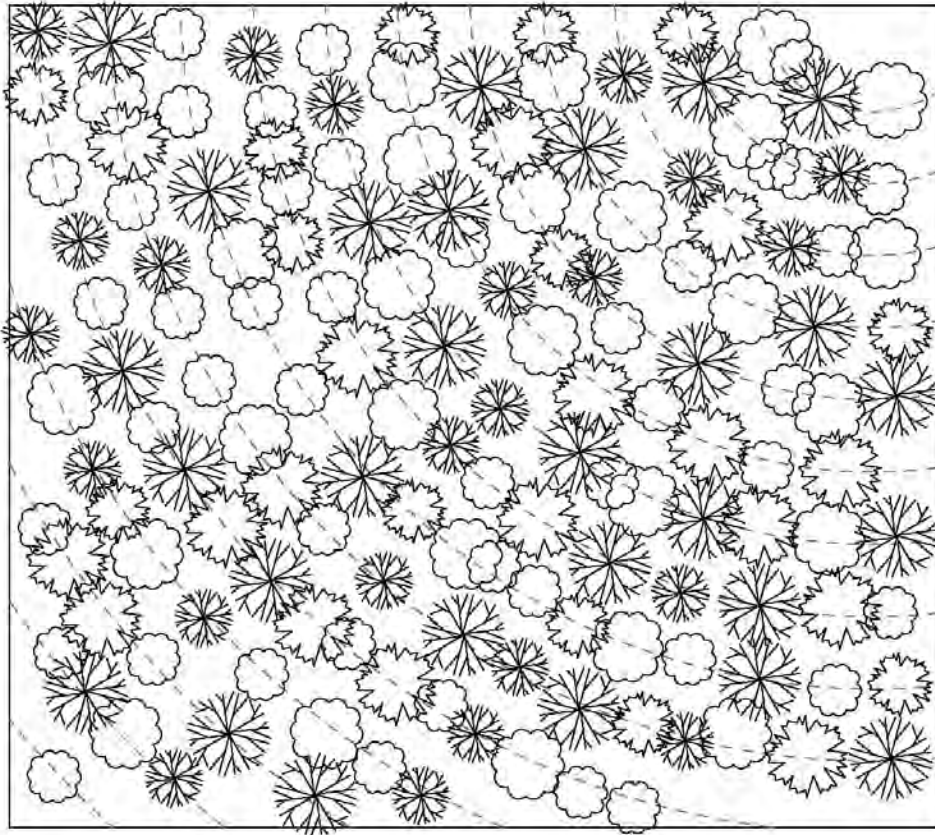

Plant placement detail not to scale.

1. Mix tree species in the staging area.
2. Set the guide curvilinear line as close to contour as possible.

Source: Used with the permission of Exploration Research, Inc. (ERI).

3.10 PROTECTION PROGRAMS

The Forest Conservation Plan must include construction period and post-construction period protection programs to protect the integrity of forest retention, reforestation and afforestation areas during construction, and to ensure the survival of these areas in the post-construction period. The construction period begins with execution of the Forest Conservation Agreement and recordation of the plat, and extends until completion of all site changes and improvements required by the approved Forest Conservation Plan. Inspection and approval of forest conservation plantings and installations by the Department of Planning and Zoning or its designee initiates the start of the post-construction period. The post-construction period is a minimum three growing season period, but may be longer when specific conditions warrant.

During this period, monitoring and forest management practices guarantee minimum survival rates or replacement of forest resources retained or created as part of the approved Forest Conservation Plan. This period ends with the release of the Forest Conservation Agreement and surety. [Chapter 4](#) provides more information about construction and post-construction period protection program techniques and practices.

3.10.1 Construction Period Protection Program

It is crucial to protect forest conservation areas from damage or degradation when approved development proposals are under construction. In addition to not clearing the trees themselves, the developer must ensure that soil is not compacted, that site drainage is not drastically altered, and that no harmful practices, such as washing of equipment or storage of materials, will occur where they will create stresses on the future health of forest communities. Areas set aside for reforestation or afforestation must also be protected or adequately prepared for the proposed planting. Activities that will not cause damage to forest resources may be permitted during the construction period as long as they have been specified in the approved Forest Conservation Plan. [Chapter 4](#) provides more information on prohibited and permitted activities. Compliance with the construction period protection program is necessary to secure the release of obligations and sureties established by the Forest Conservation Agreement. The construction period protection program must specify and/or show the following on the plan or in the written notes:

- Limit of disturbance.
- Permitted and prohibited activities.
- Treatment of the edge of surviving forest stands to adjust them to the new environmental conditions (selective thinning, pruning, removal of species susceptible to windthrow). See [Appendix E](#).
- Treatment of historic or specimen trees to protect the critical root zone and adjust them to the new environmental conditions (root pruning, pruning, special protection measures). See [Appendix E](#).
- Site preparation treatments to restore or enhance suitability for planting (soil preparation, removal of noxious weeds or invasive species). See [Chapter 4](#).
- Protective measures such as fencing and signs that will prevent unpermitted intrusions into the forest conservation areas during construction. See [Appendix E](#).
- Designation of appropriate areas for storage of equipment, vehicles (including employee parking), building materials and construction debris.
- Methods for disposal of construction debris.
- Designation of appropriate areas for washing equipment and disposing of wastewater from concrete operations.
- Temporary structures such as trailers and sanitary facilities.

- Project construction sequence, including:
 - Notification of nearby residents and business occupants about the proper use and protection of the Forest Conservation Easement areas.
 - Timing for the implementation of items listed above.
 - Timing of reforestation or afforestation plantings during the construction period and how they will be coordinated with development activities.
 - Monitoring for forest conservation requirements and performing any necessary construction period management, stress reduction, watering or corrective activities.

3.10.2 Post-Construction Protection Program

A post-construction protection and management program is required to give the forest resources saved or planted as part of the development proposal a high probability of achieving the survival rates required for release of surety, as well as long-term survival. The post-construction protection program must specify and/or show the following on the plans or in the written notes:

- Permanent protective devices required by the approved Forest Conservation Plan.
- Permitted and prohibited activities.
- Post-construction sequence, including:
 - Notification of nearby residents and business occupants about the proper use and protection of the Forest Conservation Easement areas.
 - Timing for installing and maintaining permanent protective devices to prevent unwarranted intrusions and activities.
 - Removal of all temporary structures after construction.
 - Monitoring by the applicant or the applicant's agent for continued compliance with the forest conservation requirements, including thinning, watering, fertilizing or other required measures to ensure survival and growth.
 - Removal and replacement of dead reforestation or afforestation plantings to meet growing season survival requirements.

3.11 FEE-IN-LIEU REQUESTS

When on-site or off-site planting or retention cannot be reasonably accomplished, because it would result in stands that would be small, ecologically isolated or in low priority locations, and adequate credits are not available in a forest mitigation bank, the applicant can request a fee-in-lieu payment into the Forest Conservation Fund. The request is made through submittal of a fee-in-lieu request form (see [Appendix F](#)) to the Department of Planning and Zoning (DPZ).

Before DPZ will consider a fee-in-lieu request, the applicant must demonstrate compliance with the site design requirements given in [3.7.4 Coordination with Site Design](#). Residential developments may request a fee-in-lieu for no more than one acre of forest conservation obligation, based on planting requirements inside the development site watershed. For all developments, the fee-in-lieu amount will be based on the total planting requirement for outside the development site watershed. Approval of such requests may be made by DPZ after evaluating the justifications regarding the infeasibility of fulfilling the retention, reforestation and afforestation priorities. The fee-in-lieu rate will be assessed on a square foot basis at a rate established by the County Council and will be 20% higher for development proposals outside the Priority Funding Area.

When fee-in-lieu requests are granted, the final plan and plat, or Site Development Plan or

grading plan shall note that all Forest Conservation Plan obligations have been met by the appropriate payment and that the site carries no additional restrictions related to specific forest conservation requirements.

3.12 VARIANCE REQUESTS

In accordance with the procedures of Section 16.104(b) and (c) of the Howard County Subdivision and Land Development Regulations, variances may be granted to the Forest Conservation Act requirements, if it is determined that strict enforcement of the Act would result in unwarranted hardship. Increased cost or inconvenience of meeting the requirements does not constitute an unwarranted hardship to the applicant. Variances to the Forest Conservation Act must be considered and approved or denied in writing by the Department of Planning and Zoning, the Office of Community Sustainability and the Department of Recreation and Parks.

To apply for a variance, the Applicant must submit an Alternative Compliance Application, which includes an exhibit plan and the required justification. The variance request must include a detailed description in the justification explaining how the following criteria are met through the granting of a variance:

1. Describe the special conditions peculiar to the property which would cause the unwarranted hardship.
2. Describe how enforcement of these regulations would deprive the landowner of rights commonly enjoyed by others in similar areas.
3. Verify that the granting of a variance will not adversely affect water quality.
4. Verify that the granting of a variance will not confer on the applicant a special privilege that would be denied to other applicants.
5. Verify that the variance request is not based on conditions or circumstances which are the result of actions by the applicant.
6. Verify that the condition did not arise from a condition relating to land or building use, either permitted or nonconforming, on a neighboring property.
7. Provide any other information appropriate to support the request.

No more than 30% of the limit of disturbance/critical root zone for an historic or specimen tree, as specified in Section 4.2.1, may be disturbed if the tree is to be retained. Variance requests for the removal of historic or specimen trees must provide the following:

1. Pictures of any specimen or historic trees to be removed, including a detailed assessment for each tree regarding its size, age, health, and any other conditions that may affect its survivability.
2. An alternative plan analysis explaining why the lots, roads, driveways, parking lots, structures, stormwater management devices and utilities cannot be reconfigured or relocated on the property to avoid removal of the trees.
3. A detailed explanation of why removal of the trees will not adversely affect water quality per the State of Maryland standards.

Any Maryland native specimen tree removed shall be replaced on-site by at least two Maryland native trees with a DBH of at least three inches.

Notice of a request for a complete variance of the Forest Conservation Program shall be given by the Department of Planning and Zoning to the Maryland Department of Natural Resources within 15 days of receipt of a request for a variance. Notice of a request for a variance to

individual program requirements, temporary deferral or phasing of obligations with the program requirements shall be given by the Department of Planning and Zoning to the Maryland Department of Natural Resources after a decision on the variance request is rendered.

CHAPTER 4: IMPLEMENTATION TECHNIQUES AND PRACTICES

4.0 INTRODUCTION

This Chapter sets forth the technical requirements and recommended practices for implementing an approved Forest Conservation Plan. There are three phases for implementing an approved plan:

- **Construction period.** This period begins with execution of the Forest Conservation Agreement and recordation of the plat, and extends until completion of all site changes and improvements required by the approved Forest Conservation Plan. Inspection and approval of forest conservation plantings and installations by the Department of Planning and Zoning or its designee initiates the start of the post-construction period.
- **Post-construction period.** This period is a minimum of three full growing seasons, during which monitoring and forest management practices guarantee minimum survival rates or replacement of forest resources retained or created as part of the approved Forest Conservation Plan. This phase may be extended if necessary and ends with the release of the Forest Conservation Agreement and surety.
- **Long-term management.** This phase is the full assumption by the owners of the obligation to protect and manage Forest Conservation Easement areas, and to refrain from any activities not permitted by the recorded Deed of Forest Conservation Easement.

During the first two phases, the developer has ultimate responsibility for the integrity of all Forest Conservation Easement areas. This responsibility will usually be compounded by the occupation and use of the completed project during the three growing season minimum post-construction period. Therefore, the developer also has responsibility for educating the new owners or tenants about the Forest Conservation Easement area restrictions that come with the property.

This Chapter recommends best management practices for each of these three stages of implementation. [Appendix E](#) provides sample details and specifications that illustrate many of the recommended practices and procedures. Most recommendations are presented as performance guidelines rather than mandated specifications. The purpose of including recommended practices in this Chapter and in various appendices is to assist developers and their consultants in complying with the implementation requirements of the Forest Conservation Program. The Program requires that certain survival rates be achieved. Replacement obligations and bond extensions ensue if such survival rates are not achieved. Stiff fines and mitigation requirements are leveled for violations of approved Forest Conservation Plans.

4.1 CONSTRUCTION PERIOD GENERAL PRACTICES

The construction period protection program must be approved as part of the original Forest Conservation Plan. There are two primary components of the program. The first is to protect forest retention areas and areas designated for planting during the construction period. The

second is to prepare, plant and manage the reforestation and afforestation areas. These activities must be carefully managed in coordination with other construction activities to ensure success. Many of the construction period protection measures cited in this Manual are to prevent disturbance of forest retention and planting areas. When these areas are located within the limit of disturbance, proscribed measures to protect them can be easily nullified by poor construction site management. Guidelines and requirements for addressing these two components are discussed in subsequent sections on Forest Retention Area Protection Procedures, Planting Procedures, and Maintenance and Monitoring of Planted Areas.

4.1.1 Construction Period Supervision

The developer and their designee shall be fully responsible for implementing the requirements of the construction period protection program. Any requested modifications of previously approved requirements concerning planting techniques, species or maintenance needs must be submitted by a qualified professional, as cited in Chapter 5.

4.1.2 Protection Devices

To protect against intrusion and to prevent damage of retention and planting areas during and after construction, Forest Conservation Easement areas must be posted with appropriate signs and fenced. Adapted sediment and erosion control devices may be used in place of fencing, where appropriate. The Forest Conservation Plan (FCP) shows the location of and describes the protection mechanisms to be installed. If the Department of Planning and Zoning determines that intrusion or damage will not occur, fencing may not be required. The timing of installation for the protection mechanisms may be different, depending on whether forest retention or planting is proposed. All protection devices shall remain in place until construction completion, final inspection, and release of surety, unless authorized by the Department of Planning and Zoning or its designee. More information on protection devices, including construction details, can be found in Appendix E, Figures E-1 through E-7.

4.1.3 Sediment and Erosion Control for Planting

When reforestation and afforestation involve disturbances greater than 5,000 square feet, proper sediment and erosion controls may be required. It may be necessary to protect forest retention areas from erosion and sedimentation caused by planting reforestation or afforestation areas. Before the start of any site grading, all sediment control devices shall be in place to prevent any silt or sediment from entering the forest retention or planting areas. When sediment control devices are required, a super silt fence or other device acceptable to the Howard Soil Conservation District shall be installed on the uphill side of all Forest Conservation Easement areas. Appendix E, Figures E-6 and E-7 provide examples of silt fences and erosion control structures that also serve as forest protection devices. Sediment control devices should be cleaned and maintained on a regular basis throughout the construction period. All drainage devices, inlets or swales required to maintain existing surface and subsurface groundwater conditions within the Forest Conservation Easement area must also be installed and operational prior to grading.

4.1.4 Construction Period Inspection

One year after the Forest Conservation Agreement has been signed, the Department of Planning and Zoning (DPZ) or its designee shall conduct an inspection to confirm that all forest retention areas have been preserved, all reforestation and afforestation plantings have been installed as required by the Forest Conservation Plan, and all protection measures required for the post-construction period have been put in place. DPZ must also receive a copy of the notice given to nearby residents and business occupants about the proper use and protection of the

Forest Conservation Easement areas.

If the site is not in compliance with the Forest Conservation Plan, DPZ will send a letter of notice to the applicant and schedule a re-inspection of the site. The applicant may contact DPZ at any time in the interim for an inspection. If the site is not in compliance four years after the Agreement has been signed, DPZ has the authority to initiate default proceedings. Department of Planning and Zoning inspection and written approval of forest conservation retention, plantings, installation of signs and fences, and notification of nearby residents and businesses initiates the start of the post-construction protection period.

4.2 FOREST RETENTION AREA PROTECTION PROCEDURES

Forest retention stands are extremely vulnerable to damage, long term decline, and death stemming from improper design and construction practices. Saving forests and historic and specimen trees during the construction process requires site planning, engineering practices and construction methods that respect the biological needs of trees.

Trees, especially large trees, may take a long time to show the effects of construction damage. Trees may die five or even 10 years after being weakened by construction activity. Secondary stresses such as insects, disease or drought may kill weakened trees, while the same stress would not have affected a healthy tree.

This section guides the applicant through the construction phase of a project, ensuring that construction activities will not adversely affect the forest retention areas. In addition, a Maryland Licensed Tree Expert or ISA Certified Arborist will also be able to provide information about specific tree protection strategies.

4.2.1 Critical Root Zone

Protecting trees from construction damage means protecting sufficient roots to provide the trees with adequate water and nutrient uptake for the existing leaf area and to maintain the physical stability of the tree. There are about as many roots as there are twigs and branches in the tree canopy; if roots die, branches will die to keep the tree in balance. The critical root zone is the area of roots that must be protected to ensure the continued health of the tree.

Tree root systems are typically shallow. Ninety-five percent of the roots of most trees will be found in the upper 12-18" of the soil, and most of the roots that supply nutrients and water to trees are found just below the soil surface. Since the roots only penetrate a thin layer of soil, they must spread far from the tree, beyond the edge of the canopy. The ratio of root expansion to crown spread can be 2:1 or larger on open grown specimen trees and can be significantly larger (up to 5:1) for trees growing in the interior of forest stands. The increase of root expansion in forest stands occurs because adjacent trees restrict the crown spread of a tree, while its roots can constantly grow through the soil medium. Trees in forest stands also become interdependent on each other for physical support during high winds. Removal of adjacent trees and destruction of roots can cause windthrow long after the completion of construction.

Tree roots also need a balance of water and air in the soil. Air only penetrates 12-18" into the soil. Stress and decline in tree health result when soil is piled on top of existing roots, or when roots are suddenly forced to sit in waterlogged soil or overly dry soils caused by topography changes during construction. Soil compaction during construction blocks the flow of air and water within the soil, and makes root growth difficult. Soils that have a Proctor Density of 80 to

85% compaction or greater cannot support healthy root growth. Existing roots in soil that becomes heavily compacted usually die. Trees growing in disturbed or tilled soils usually die back in proportion to the root area disturbed. Even minor disturbances such as tilling within the root zone for lawn installation will cause harm.

The critical root zone varies from species to species and from soil type to soil type. The critical root zone also changes with the size of the tree, the proximity of other trees, the amount of past human influence (agriculture or construction) in the vicinity of the tree, and changes in soil type or groundwater. It is difficult to generalize for all trees, but also difficult to field examine the root systems of all of the trees in question. Therefore, the following calculation should be used unless other methods are demonstrated to protect the critical root zone:

- For the edges of stands, the limit of disturbance (LOD) must be a minimum of 15 feet from the Forest Conservation Easement.
- For historic and specimen trees, the LOD is defined as a circle around the tree with a radius of 1.5 feet for each 1.0 inch of DBH, or 15 feet from the Forest Conservation Easement, whichever is greater (see [Appendix E, Figure E-8](#)). No more than 30% of the critical root zone for an historic or specimen tree should be disturbed.

Protection devices include signs and fencing. Signs are typically placed at the edge of the Forest Conservation Easement. Fences may be located at the edge of the LOD or the Forest Conservation Easement, depending on individual circumstances. If fences are required at the edge of the LOD during the construction period, they may need to be removed or relocated to the edge of the Forest Conservation Easement for the post-construction or long-term management period.

4.2.2 Effects of Construction on Forests

Throughout the construction period, applicants should monitor the effect of the proposed construction activities on the forest retention areas. [Figure 4-A](#) provides a list of potential construction effects and remediation techniques. Developers and their contractors should protect against these effects and correct the resultant damage should such impacts occur. [Appendix E](#) provides sample details and specifications for many of the corrective measures outlined below.

Figure 4-A: Mitigating Construction Impacts on Forest Retention Areas

Construction Activity / Related Problems / Concerns	Stress Reduction Techniques and Remedies
Soil and Root Compaction	
<p>Avoid unnecessary compaction due to construction activities such as temporary access, grade changes, digging for foundations, roads, or utility construction.</p>	<ul style="list-style-type: none"> ▪ Aerate soil and roots when needed. ▪ Additional mitigating activities for root injury or soil disturbance may include root pruning, air spading, composting, mulching and watering. ▪ Specimen and historic trees and groups of trees are nearly always growing on soils previously influenced by human activity. If the soils under these trees are already compacted, they should have air spade treatments.
Root Disturbance or Injury	
<p>Avoid affecting the critical root zone of retained areas.</p>	<p><u>Root Pruning:</u> Roots may be pruned when needed to reduce the effects of damage to uptake or support functions. Special machinery or techniques may be required.</p> <ul style="list-style-type: none"> ▪ Prune before construction disturbance as shown in Appendix E, Figure E-9. ▪ Cut cleanly using well-maintained pruning equipment. ▪ Cover exposed roots immediately with topsoil, leaf compost or other suitable material. ▪ For trees with DBH greater than 15 inches, conduct root pruning up to one entire growing season before construction disturbance. ▪ Water before and after root pruning, as needed. <p><u>Crown Reduction:</u> If the root system has been significantly reduced (more than 30%) or there are dead, damaged or diseased limbs, the following crown reduction or pruning is recommended:</p> <ul style="list-style-type: none"> ▪ No more than 1/3 of the crown should be removed at one time (see Appendix E, Figure E-10). ▪ Prune at optimal time of the year for the type of plant: For ornamental flowering trees, after flowering and before bud set. For non-ornamental flowering trees, in late winter, early spring or mid-summer. ▪ Monitor for signs of stress.

Limb or Trunk Injury	
Avoid mechanical injury to trees. This will affect not only the appearance of retained trees, but their ability to take up nutrients and water through the cambium layer just under the bark and, when more extensive, their support.	Prune before construction activities affect tree canopies. See also crown reduction, above. Prune any limbs damaged by construction activities (see Appendix E, Figure E-10).
Too Much Water	
Excess soil moisture will drown the tree roots, limiting their ability to absorb oxygen.	Do not allow standing water for more than 2 days. Avoid grading around a forest retention area when this will result in water ponding.
Too Little Water	
Grading will alter the soil moisture regimes in the critical root zone, particularly in grade cuts. Avoid lowering the water table levels.	Avoid grade cuts around a forest retention area when this will alter the hydrology of the site. If this occurs, compensate by additional monitoring and watering when needed. Do not over water. Very old trees (30" or larger DBH) should be manually irrigated several times during the first two summers following grading in their vicinity.
Disease	
Disturbances to forest retention areas and nearby areas may weaken tree resistance to insects, fungi or other pests. Trees in construction zones are more susceptible to attack by pests than trees in undisturbed conditions.	Monitor forest edges and specimen and historic trees for disease and insect problems during and after construction. Additional watering and supplemental tree care measures may be necessary to reduce stress and improve overall tree health.
Susceptibility to Windthrow	
Individual trees that grow in a forest are protected from prevailing winds or sudden gusts. Trees growing in conditions that limit adequate structural root development, such as hydric soils, or species that adapt by shallow rooting may not be appropriate in a new edge condition. Some species of trees or individual trees may not be suitable for retention at the retention boundary without certain treatments.	Susceptible trees may require removal or pruning. Selective clearing and replanting methods as discussed in Chapter 3 may be a means to mitigate this type of disturbance. Planting a new "edge" of trees may be needed to protect the former interior trees from wind and other effects of weather.
Sunscald	
Canopies that are opened and allow more sunlight during the growing season may create drought stress conditions for certain shade tolerant species and sunscald, particularly on thin-barked species. Generally, this may be avoided by limiting cutting and clearing to the dormant season.	Susceptible trees may require planting a new "edge" of trees to protect the former interior trees from direct sun and other effects of weather as means to mitigate this type of disturbance.

Other protection devices or techniques, including but not limited to, those listed below may be called for in the FCP. [Appendix E](#) contains sample specifications and details for these techniques.

- Tree wells (see [Appendix E, Figure E-11](#))
- Retaining walls (see [Appendix E, Figure E-12](#))
- Sidewalk over critical root zone (see [Appendix E, Figure E-13](#))
- Paving with aeration over roots (see [Appendix E, Figure E-14](#))
- Pier wall supports over the critical root zone (see [Appendix E, Figure E-15](#))
- Tunneling through the critical root zone (see [Appendix E, Figure E-16](#))

4.2.3 Protection Measures for Forest Retention Areas

The FCP not only locates the forest retention boundary, but also includes details and specifications for forest protection. As a construction document, it directs construction contractors and others in the correct design, installation, timing and placement of specific protection devices and protection measures. The following are required construction period protection measures for all forest retention areas:

- Install all protection devices in accordance with FCP details and specifications.
- Ensure that all forest retention area protection devices are visible, well-anchored and not attached to trees prior to beginning clearing, grading or construction; and remain in place and are maintained throughout the construction protection period.
- Abide by the construction sequence, which includes installation of sediment and erosion control measures prior to beginning clearing, grading or construction; installation and removal of protection devices; inspections; and other activities that may be required to implement the proposed protection measures.
- Do not locate any equipment, vehicles, machinery, dumping, storage, or other construction activities; or burial, burning, or other disposal of construction materials inside forest retention areas.
- If fires are permitted in the site construction area, conform with state and local regulations for fire control, and do not allow any fires to enter the retention area or its canopy.
- Monitor forest retention areas for signs of stress and institute appropriate stress reduction techniques.

The edge of the retention area must be staked by the applicant prior to clearing. This field edge should be adjusted along the critical root zone of trees in the proposed retention area as shown in [Appendix E, Figure E-8](#).

4.2.4 Prohibited and Permitted Activities in Forest Retention Areas

Forest retention areas must be protected from construction activity and other stresses to protect the forest stand from damage. The forest retention practices for a development must address the specific needs and stresses the proposal may cause. The following section provides detailed information on the types of activities that are prohibited and that may be allowed in the forest retention area.

Unless specifically approved by the Forest Conservation Plan, no construction activity shall be permitted within the forest retention area. The following activities are **prohibited**:

- Grading cut or fill.

- Removal of existing ground plane vegetation or organic leaf layers, except for invasive exotic vegetation.
- Storage or stockpiling of construction supplies and equipment, including machinery, construction trailers, fill, topsoil and trash.
- Disposal of construction waste, including concrete truck wash off, paints, solvents, contaminated runoff, oils, fuels, or any other substances that are harmful to plants or animals.
- Temporary stormwater or sediment control structures.
- Roads, driveways or parking.
- Patios or decks.
- Foundations, walls or building footprints.
- Underground utilities requiring an easement or trenching.

Activities that will not cause damage to forest resources **may be permitted** during the construction period, as long as they have been specified in the approved Forest Conservation Plan or authorized by the Department of Planning and Zoning or its designee. Section 4.4 and Section 4.5 provide guidance for relevant maintenance and monitoring activities. Activities that may be permitted would include:

- Maintenance activities (watering, and mechanical and chemical control of insects, diseases, noxious weeds and invasive plants).
- Selective thinning and pruning to remove diseased trees or damaged vegetation.
- Planting of supplemental native plant material.
- Removal of tree limbs that are outside the limit of disturbance and interfere with construction.
- Removal of dead or dying trees that may pose a threat to nearby structures or uses if they fall outside the Forest Conservation Easement.
- Forest thinning or tree removal that is consistent with recognized forestry practices to improve forest health.
- Removal of trees on the edges of tree groups or forest stands whose trunks are within the critical root zone of other trees, but which do not have sufficient critical root zones of their own to allow them to survive.
- Removal of vines or other herbaceous plants that threaten the ecological balance of the remaining plants in the forest retention area.
- Stabilization measures to check existing erosion problems.
- Unpaved trails that do not require the removal of trees greater than 2 inches DBH.
- Paved walks and paths that meet the following requirements:
 - They do not require the removal of trees of 6-inch DBH or greater.
 - They are constructed of materials that can be installed using equipment with a maximum weight of 1/2 ton.
 - They are the minimum width necessary to serve their expected use and are no wider than 8'-0".
 - They are placed no closer than 6' from the base of the trunk of any tree over 12" DBH.
 - They are constructed without filling greater than 6".
- Split rail or similar open board fences without any meshing, which do not require continuous footings or which have posts no closer than 6'-0" on center, and which can be manually installed.
- Removal of any existing walks, walls, roads or other structures, non-native plant debris, trash, and large piles of dumped natural debris, as required. These items should be removed without the use of heavy equipment.

4.3 PLANTING PROCEDURES

For reforestation and afforestation to be successful and meet the required survival rates, it is critical that appropriate site and soil preparation, planting procedures, and management techniques be followed. Reforestation or afforestation will often occur on land already disturbed by development activities or past agricultural activities, thus it may be located on land that will require substantial preparation to enable native forest plantings to survive and thrive. Disturbed sites are susceptible to colonization by invasive exotic species and may require early and sustained efforts to bring these species under control. Reforestation and afforestation plantings will also require a great deal of management once they are installed.

The recommendations in this section should serve as a guide for controlling invasive exotic species, preparing planting sites, and using proper native plant selection and planting procedures. The Department of Recreation and Parks, Natural Resources Division, can provide assistance if applicants require technical advice with site preparation. The Natural Resources Division can perform a site assessment and meet with the applicant to offer guidance on best management practices for site preparation.

4.3.1 Invasive Exotic Plants

Exotic plants are plant species that are not native to the area where they are growing. Hundreds of exotic plants occur in the wild in Maryland. Most plants used in horticultural applications are not native to Maryland, and many can escape into the wild, but most exotic species do not pose a serious threat to native vegetation in undisturbed areas. However, some invasive exotic plants are a significant problem because they displace native species and can change the structure and composition of natural communities. They lack the predators, competitors, diseases or parasites that help control their populations in their native habitat. They compete successfully against existing native species. A list of invasive exotic species appears in [Appendix D](#).

The presence of exotic species usually indicates a history of site disturbance and may indicate a degraded natural community. Many species of invasive exotic plants, particularly woody vines, can suppress forest regeneration. The worst species are those that cause damage, are easily established and readily dispersed, such as Japanese honeysuckle (*Lonicera japonica*) and devil's tail tearthumb or mile-a-minute vine (*Polygonum perfoliatum*). Kudzu (*Pueraria lobata*) is a rapidly growing vine that can quickly cover vegetation, blocking sunlight and girdling or toppling trees.

Some species, such as bamboos, are extremely persistent and destructive, but are unlikely to become established unless planted. Other species, such as tall fescue (K31 fescue) (*Festuca elatior*), sericea lespedeza (*Lespedeza cuneata*) and crown vetch (*Coronilla varia*), although not strongly invasive, should not be planted in or adjacent to natural areas, because they are extremely persistent and are unlikely to be naturally replaced by native species.

English ivy (*Hedera helix*), climbing euonymus (*Euonymus fortunei*), burning bush (*Euonymus alatus*), Japanese honeysuckle and Norway maple (*Acer platanoides*) are particularly pernicious in forested environments, because they are adapted to low light conditions and can invade high quality forests with closed canopies. Bird-dispersed species, such as Japanese honeysuckle, can readily invade the interior of forested habitats by colonizing light gaps caused by fallen trees. Some species, such as wisteria (*Wisteria* species) and Japanese honeysuckle, can

rapidly invade the shady interior of a forest from a sunny forest edge. They send out ground level vines that are subsidized by the rapidly photosynthesizing portions of the plants growing in full sun.

Multiflora rose (*Rosa multiflora*), Japanese honeysuckle, devil's tail tearthumb, ailanthus (*Ailanthus altissima*), autumn olive (*Elaeagnus umbellata*) and callery pear (*Pyrus calleryana*) are abundant across Howard County. In nearly all conditions, these invasive species will out-compete native vegetation unless controlled.

4.3.2 Controlling Invasive Exotic Plants

Control of noxious weeds, such as Canada thistle (*Cirsium arvense*), is required by State regulation. [Appendix D](#) lists noxious weeds in Maryland and [Appendix G](#) provides references for information about their control.

A site visit should be performed prior to any site preparation work to evaluate existing conditions and develop a management plan. In accordance with accepted Integrated Pest Management practices, chemical control treatments should be limited, targeted, properly timed and used in accordance with the manufacturer label. Treatments should be applied in a manner that minimizes risks to human health, beneficial and non-target organisms, and the environment. Site preparation to control invasive exotic plants should begin as early as possible. On sites where invasive plants dominate, preparation should begin at least one year in advance of planting. This gives time to gain control over problematic species, such as mile-a-minute vine, thistle and multiflora rose.

The use of native cover crops for reforestation and afforestation areas is recommended to help suppress the growth of invasive species. Grass mixes planted following disturbance stabilize soils and do not inhibit tree growth in the same manner as other invasive plants. In fact, well-established grasses reduce germination rates of invasive species, including ailanthus and devil's tail tearthumb. The following planting recommendations outlined below can reduce competition from sod-forming grasses and other invasive plants.

On reforestation/afforestation sites where planting, natural regeneration, or selective clearing and supplemental planting is proposed, and sufficient numbers of desirable trees and shrubs do occur, the following procedures are recommended to control competing vegetation and remove invasive exotic plants:

- Fell any mature, invasive exotic trees, including ailanthus and callery pear trees, on the site. To prevent sprouting, treat the stumps with an appropriate herbicide. The stumps should be treated within five minutes of felling each tree and in accordance with the directions and precautions on the label. These species can also be treated in the dormant season with a basal bark application of herbicide and basal oil.
- Any large vines that are growing on existing native trees should be cut at ground level and at breast height, to ensure a section of the vine has been cut and removed. Stumps of vines can be treated with an herbicide to suppress re-growth.
- Mow area to reduce invasive exotic vegetation. Care should be taken to mow around native trees and shrubs that are regenerating on their own. It is encouraged that the mowing be completed during the dormant season to conserve ground nesting birds and pollinators.
- Revisit site in 2-3 weeks and spot treat invasive vegetation that regenerates by applying herbicides using a hand-held applicator (for example, a backpack sprayer with a fine

mist nozzle). All herbicides should be used in accordance with the directions and precautions on the label.

- Retreat invasive species 1 to 2 times per growing season where invasive vegetation regeneration occurs.
- Mow area prior to planting.

4.3.3 Site and Soil Preparation

Site and soil conditions should be evaluated prior to planting to determine if special preparation techniques may be needed. Nutrient, organic matter, soil texture and other analyses may be required to determine necessary soil amendments or treatments, especially for disturbed sites. Prevailing soil moisture conditions and potential changes in hydrology should also be evaluated for the proposed planting techniques. The proposed grading plan, prior site analysis and on-site assessment will be important to this evaluation.

Proper plant installation in undisturbed soils, where characteristic soil profiles can be recognized and topsoil is present, may not require extensive site preparation. On disturbed sites when soils have been compacted, or when organic or topsoil layers have been removed by grading, or where prior use has altered the soil composition, soil treatment will be necessary prior to planting.

Prior land uses can have a significant impact on site conditions. Former crop sites may have a compacted layer below the plow zone, there may be problems with residual herbicides and weed problems may emerge the first year that herbicide use is stopped. Pasture sites often have established weeds and voles are generally common.

Certain areas, especially priority planting areas such as stream buffers, floodplains and steep slopes, may require precautions before planting and/or during maintenance and monitoring. The following provides more information for appropriate site and soil preparation techniques for disturbed and stream buffer planting sites. Additional guidance is also available in *Riparian Forest Buffer Design and Maintenance*, June 2005, MDNR Forest Service, https://www.chesapeakebay.net/what/publications/riparian_forest_buffer_design_and_maintenance.

Disturbed Sites

Disturbed sites often have compacted soils caused by the use of heavy equipment during the construction process. Soils that have a Proctor Density of 80 to 85% compaction or greater will not support healthy plant growth, so a soil compaction test is recommended. Compacted soils may need air spading, core aeration, tilling, deep ripping (deeper tillage) and/or soil amendments.

In disturbed areas, soils should be treated by incorporating composted organic material within the top 12 inches and with other needed amendments, as determined by a soils analysis. Soil amendments, by definition, include modifications of soils to improve structural characteristics, such as bulk density or porosity. Natural amendments, such as organic mulch or leaf mold compost, are preferred. On development sites, the use of fill materials, whether from on-site or off-site sources, may increase the need for such amendments. When fill material is used at the planting site, it should be clean fill topped with 12 inches of native organic topsoil. Reserved topsoil from areas of the site that will be developed may be available to enhance the soil in the reforestation or afforestation areas. If supplemental fill is required, it may be mixed with the reserved topsoil.

Stockpiling of native topsoils must be done in such a way that the height of the pile does not compact or damage the seed bank. Topsoil should have a minimum organic content of 2%.

Stream Buffers

Borders of streams and other waterways may have been damaged before reforestation and afforestation. These areas may need more extensive soil and slope restoration work before reforestation or afforestation can be successful. The following are guidelines for any work within a riparian zone.

- Correct any erosion problems.
- Minimize or eliminate any chemical use. Only those chemical treatments approved for use in riparian areas should be used. For information about herbicide applications, contact the Maryland Department of Agriculture Pesticide Regulations Section at 410-841-5710. Additional information is available at https://mda.maryland.gov/plants-pests/Pages/pesticide_regulation.aspx.
- Maintain an undisturbed leaf layer and understory or ground plane planting. If the ground plane is disturbed, replace with suitable herbaceous cover.

4.3.4 Planting and Maintenance Timing

Recommended planting times during the year depend on the size and type of stock being used. Planting must occur before June 30 to be credited toward the current growing season. General guidelines for planting and other practices are shown in [Figure 4-B](#). The shaded areas in the figure denote the best times for the specified task.

Figure 4-B: Planting and Maintenance Calendar

Tasks	Jan	Feb	Mar	Apr	May	Jun	Jul	Aug	Sep	Oct	Nov	Dec
Planting balled and burlapped trees			■	■	■					■	■	■
Planting container grown trees			■	■	■					■	■	■
Planting bare root whips and seedlings		■	■	■								
Survival inspection					■	■	■	■	■			
Fertilizer (slow release only) (a)	■	■	■	■	■					■	■	■
Water (irrigate during times of dryness) (b)			■	■	■	■	■	■	■	■		
Monitoring (c)	■	■	■	■	■	■	■	■	■	■	■	■
Mowing (d)				■				■	■	■	■	
Pre-emergent herbicide treatments			■	■					■	■	■	
Post-emergent herbicide treatments				■	■	■	■	■	■	■		
Pruning (e)	■	■	■	■	■	■	■	■	■	■	■	■

Source: Howard County Department of Recreation and Parks

- (a) Depending on site conditions.
- (b) Depending on site conditions. Weekly watering is strongly recommended from May to Oct unless monthly rainfall equals 1".
- (c) Minimum of 3 times per year.
- (d) Mowing should be avoided from April 15 - August 15, during the primary bird nesting season. The no mowing period should be extended to November 15, if pollinator habitat is present. Mowing must be approved by the Department of Planning and Zoning or its designee.
- (e) Dead and broken limbs only.

This calendar summarizes some of the recommended times for basic reforestation and stress reduction activities. The planting and care of trees is most successful when coordinated with local climatic conditions. Activities during November through February should take ground conditions into account.

4.3.5 On-Site Inspection and Storage of Plant Material

Plants should be delivered to the site on a tarped or covered truck. Planting stock should be inspected prior to planting. Plants not conforming to the American Standard for Nursery Stock specifications for size, form, vigor, roots, trunk wounds, insects and disease should be replaced.

Planting should occur within 24 hours of plant material delivery to the site. Plant materials left unplanted for more than 24 hours should be protected from direct sun and weather and kept moist. Balled and burlapped trees should be planted within three days. Container grown stock should be planted within two weeks. On-site or local transplanted materials should be stored in tree banks if unplanted for more than 24 hours and bare root stock unplanted for more than 24 hours should be heeled in (see [Appendix E, Figure E-17](#)).

4.3.6 Plant Installation

Research has shown that root systems of trees planted in small holes with imported backfill mix soils are likely to remain confined to the pit and not extend their roots into the adjacent natural soil. Such trees have lower survival rates. Tree pits should not be excavated more than 24 hours before planting. A planting pit should have a minimum width equal to 2.5 times the diameter of the root ball or container. The sides and bottom of the pit should be scarified prior to plant placement. The tree should be placed such that the top 10% of the plant is higher than the surrounding grade. Backfill the pit with a soil mix comprised of stockpiled parent soils, amendments and chemical additives, as determined by the soil analysis, to correct the pH, soluble salts and available soil nutrients (also see Soil and Site Preparation, above). Ensure that soil is not placed on top of the roots of newly planted trees. Cover the pit with 2 to 3 inches of mulch, but keep mulch 3 to 4 inches away from the tree trunk. Use watering to settle soil backfilled around trees (see [Appendix E, Figure E-18](#)).

Additional example details and specifications for plant installation are provided below and in [Appendix E](#).

- **Steep Slopes**

In areas of 15 to 25% slopes with soils having an erodibility index (K) value greater than 0.35, soil disturbance should be limited to a planting pit with a width of 12 inches beyond the root ball or container for nursery stock (see [Appendix E, Figure E-18](#)). In areas of steep slopes (25% and greater), the Department of Planning and Zoning may approve the use of smaller nursery stock, seedlings and/or woody plant hydroseeding for reforestation or afforestation, if appropriate to minimize slope disturbance. Planting on open or disturbed steep slopes eventually will stabilize them. Until the roots become established, however, there may still be erosion problems. Monitoring the stability of the soil will be important to the survival of the trees. For areas of large-scale disturbance, soils must be stabilized using a non-turf-building herbaceous cover or biodegradable engineering fabric.

- **Container Grown Stock**

Successful planting of container grown stock requires careful site preparation and inspection of the plant material root system. Use caution when using plants grown in a soil medium differing from the soil on the planting site. The plant should be removed from the container and the roots gently loosened from the soil. If the roots encircle the root ball, substitution is strongly recommended. J-shaped or kinked root systems should also be noted, and the plants replaced if necessary (see [Appendix E, Figure E-18](#)).

- **Balled and Burlapped Trees**

Balled and burlapped trees must be handled with care while planting. Trees should not be picked up by the trunk or dropped; both these practices may separate the trunk from the root ball. Prior to planting, root balls should be kept moist (see [Appendix E, Figure E-18](#)).

- **Seedlings/Whips**

Small stock, such as bare root seedlings and whips, if approved for planting in mitigation banks or on steep slopes, can be planted by manual methods of planting using shovels, planting or dibble bars, and mattocks (See [Appendix E, Figure E-19 and E-20](#)). Machine planting of seedlings may be used on flat to gently sloping sites. Roots must not be planted in a J shape.

Extreme care should be taken to ensure retained moisture of the roots. An anti-desiccant gel should be used to protect root systems from drying. When planting seedlings and whips, a moist carrying container should be used to prevent desiccation and areas planted with seedlings or whips should be mulched after planting (see [Appendix E, Figure E-20](#)).

- **Woody Plant Hydroseeding**

Woody plant hydroseeding, if approved for steep slopes, should include a mix of cover crop and tree seedlings.

- **Staking or Guying**

Staking or guying of larger trees is not recommended except in areas of high winds. Staking or guying may be used for trees larger than 8 feet in height. Movement is necessary for development of trunk taper and wind resistance in the planted tree. When staking or guying is used, the post-construction period protection plan should specify the removal of all material from the tree after the first growing season (See [Appendix E, Figure E-21](#)). If trees are still staked or guyed at final inspection, the site will not be approved for release of the surety.

- **Tree Shelters**

Tree shelters are required for all planting stock and should be installed in accordance with manufacturer recommendations. Tree shelters may be inserted 2 to 3 inches below the ground to limit damage from mice and voles (see [Appendix E, Figure E-22 and E-23](#)). The final inspection will determine whether the shelters should remain in place or be removed prior to release of the surety.

4.4 MAINTENANCE AND MONITORING OF PLANTED AREAS

Maintenance and monitoring for reforestation and afforestation sites are essential to ensure healthy new forests and to achieve the required survival rates. This section provides guidelines for assessing water, nutrients, invasive exotic plants, pests and other needs when developing a maintenance and monitoring program. This information should be incorporated into the construction period and post-construction period protection programs that are part of the approved FCP.

4.4.1 Watering

A watering plan should only be implemented to compensate for deficient rainfall patterns and inadequate soil moisture. Trees can die from too much water as well as too little.

- **When to water:** Newly planted trees may need water as much as once a week for the entire first growing season. The next two years, in contrast, may require watering only a few times a year (once a month during July and August). After that, trees should only need water in severe droughts. Bare root transplants, if sufficiently watered during planting, may not need water for almost 2-4 weeks after growth begins. Balled and burlap material may require more frequent watering.
- **Soil and watering:** Soil texture influences the downward flow of water. Soils with more clay tend to retain more water and can be watered less often; soils with more sand drain more quickly and need to be watered more often. If the soil was well prepared before planting, there should be few drainage problems. Restricted downward water penetration indicates the soil may have been compacted during construction and not aerated before planting, or there may be a clay hardpan. Untreated hardpan will ultimately restrict root growth. If needed, soil should be aerated and hardpan should have tilling or deep ripping prior to planting to ensure good water penetration.
- **How to water:** The best way to water is deeply and slowly using a regular hose, a soaker hose or drip irrigation. For larger trees, start by watering the root ball thoroughly. The watered area should be enlarged to include the whole root zone as the tree becomes more established.
- **Watering and mulch:** A thin layer of mulch (2-3" deep) atop the surface roots of newly transplanted trees prevents roots from drying too quickly, while still providing air movement to the roots. If mulch is too thick (4" deep or greater), it can inhibit moisture from penetrating to the soil and roots.

4.4.2 Fertilizing

Fertilizing is the chemical modification of soils to correct for a specific nutrient deficiency. These deficiencies are most effectively identified in a laboratory soils analysis. Nothing should be added to the soil without first testing to determine any nutrient needs.

- **What nutrients to apply:** Trees depend on three major nutrients, nitrogen, phosphorus, and potassium, and a host of other minor ones (or micronutrients) such as calcium, magnesium and iron. Of the major nutrients, nitrogen is usually most needed. In most undisturbed soils, most of the micronutrients are available in abundance. If the soil is very acidic or basic, these nutrients may not be available to the plant and soil pH should be adjusted.
- **When to fertilize:** Even when soils are deficient in nitrogen, do not fertilize within the first growing season after planting. Too much nitrogen may cause a spurt of canopy growth, which the roots cannot support. Therefore, do not add fertilizer until the early fall or early spring following the first growing season.
- **What type of fertilizer:** Organic fertilizers are preferred to synthetic fertilizers. Bone meal or seaweed-based products are available commercially. Organic fertilizers have a slow release effect that can supply nutrients to the plant as needed, while minimizing the

risk of excess nutrients entering the forest system and the water supply. Some synthetic fertilizers can mimic this slow-release action and may be appropriate for use.

4.4.3 Controlling Competing Vegetation

Unfortunately, reforestation and afforestation locations, such as abandoned fields and disturbed sites, are often highly susceptible to invasion by invasive exotic plants, noxious weeds, and other unwanted vegetation or weeds. In some cases, unwanted vegetation, especially exotic invasive vines and shrubs, growing near newly planted trees can take over the site. As a preventive measure, consider the potential for growth of invasive species (see [Appendix D](#)) when choosing a reforestation or afforestation area. Once a site is selected, adequate site preparation is an effective way to minimize future problems from competing vegetation. Information about proper site preparation is given above under [4.3.2 Controlling Invasive Exotic Plants](#).

The extent to which competing vegetation must be controlled depends on the ability of the desired plant material to compete for available sun, soil moisture and nutrients. More control is usually required for smaller trees, although some shade tolerant species survive among the unwanted vegetation and subsequently shade it out when they reach a greater height. The following techniques are recommended to control competing vegetation. Field inspections to monitor invasive vegetation should start in the spring and continue into the fall.

- **Why to use mulch:** Mulch is one of the best weed deterrents. Spread a 2 to 3" layer of mulch over the root area of the newly planted trees, avoiding direct contact with the trunk, a prime spot for fungal growth. Mulch also helps maintain the soil moisture level and may provide a buffer for any equipment, such as mowers, that may be used to maintain the area. Mulching and manual control of competing vegetation is more compatible with the long-term forest health than the use of herbicides.
- **When to use mechanical control:** Mechanical removal or topping of competing plants, such as mowing, may be desirable if invasive exotic plants pose a serious threat to reforestation or afforestation areas. Mowing should be avoided during the primary bird nesting season (April 15 – August 15) and the no mowing time should be extended to November 15 if pollinator habitat is present. Mowing of forest conservation areas, even to control competing vegetation, must be approved by the Department of Planning and Zoning or its designee. The frequency and timing of removal will affect the composition of the plant community.
- **When and how to use chemical control:** Mulch and mechanical control are preferable to chemical control, especially near streams, wetlands or areas of human occupancy. Controlling competing vegetation with herbicides should be carefully assessed so that effects on desirable plants, including those that self-seed or colonize the site, soils, and surface waters are carefully monitored and minimized. In accordance with accepted Integrated Pest Management practices, chemical control treatments should be limited, targeted and properly timed. Treatments should be applied in a manner that minimizes risks to human health, beneficial and non-target organisms, and the environment. If chemical control of invasive vegetation is needed, the following methods are recommended:
 - Spot treat invasive vegetation by applying herbicides using a hand-held applicator (for example, a backpack sprayer with a fine mist nozzle). All chemicals should be used in accordance with the directions and precautions on

- the label.
- Selectively retreat invasive species throughout the growing season, applying herbicides only to areas where invasive species sprouts occur. Again, any chemical should be used in accordance with the directions and precautions on the label.

4.4.4 Protection from Pests, Diseases and Mechanical Injury

Damage by pests, disease and mechanical injury are often interrelated issues and are also strongly related to problems with invasive exotic plants. Deer browsing and rodent damage can reduce the number of plants, leaving the ground open for invasive exotic species. Mechanical and animal damage can weaken plants and make them more susceptible to pests and diseases.

Integrated Pest Management (IPM) is one of the most effective and safest approaches for maintaining a healthy forest. IPM basics include proper species selection for the site, good pruning, mulching and fertilizing practices, regular monitoring, and proper timing of necessary sprays. Good cultural practices will minimize the amount of spraying. Professional IPM programs have reduced pesticide use by 90%. Some aspects of a full IPM program include:

- **Eliminate low vegetation:** Elimination of some low vegetation before planting helps to control the rodent population, which thrives in brushy environments.
- **Maintain tree shelters.** Tree shelters can protect trees from animal damage, in particular deer browse and buck rub. Plastic or wire mesh shelters, as shown in [Appendix E, Figure E-23](#), are recommended because they provide protection from animal damage, while avoiding problems associated with conventional tree shelters that have solid sides. The solid-sided shelters act as mini-greenhouses to speed growth. However, these trees need more water than those planted without tree shelters or with mesh shelters. Solid-sided tree shelters also require monitoring and timely removal to ensure wildlife impacts are minimized. Solid-sided shelters often provide a protected microclimate that attracts voles and mesh tops may be needed to ensure that birds are not trapped inside.
- **Spread mulch:** Mulching around the trees minimizes trunk damage from mowers. Wounds provide an entryway for pests. Mulch can also suppress vegetation that would provide nesting places for rodents.
- **Prune:** Pruning dead and diseased branches with a clean cut prevents establishment or spreading of disease.
- **Avoid tree wrap:** Sunscald is a problem for thin-barked young trees. Tree wrap was commonly used to protect trees from sunscald, but is no longer recommended due to the increased opportunities for insect infestation and disease. An alternative to wrapping is to allow small non-competitive branches, commonly pruned during or before planting, to grow on the sunny side of the trunk to help shade the trunk.
- **Minimize use of tree stakes.** Newly planted trees usually do not have the structural roots to provide adequate support during high winds. If stakes and guy wires are used in high wind prone areas, they should be removed after one growing season or damage to the tree may result as it grows larger.

4.5 POST-CONSTRUCTION PROTECTION PRACTICES

The post-construction period protection program must be approved as part of the original Forest Conservation Plan. The Forest Conservation Agreement includes sureties covering all costs of the necessary protection and management activities required by the post-construction protection program. The post-construction protection program remains in effect for a minimum of three growing seasons. A longer period may be needed to achieve the required survival rates and ensure the release of Forest Conservation Agreements and sureties.

Many of the protection and management practices for the construction period must be continued during this period. The responsibility to meet the survival standards for each growing season requires adequate watering, replanting, thinning or other appropriate measures. Also, inappropriate uses or intrusions must not occur, a responsibility that requires the knowledge and cooperation of the new occupants of the development.

The developer and their designee shall be fully responsible for implementing the requirements of the post-construction period protection program. All forest retention, reforestation and afforestation areas should be inspected at specified times during the life of the post-construction protection period. The Department of Planning and Zoning or its designee will conduct a final inspection to ensure that the required survival rates have been achieved in accordance with the Forest Conservation Agreement before release of sureties.

There are five primary components of the post-construction program: inspection, management of retained or new plantings, replacement of dead or damaged material when necessary, education of new occupants of the development, and final inspection and release of the developer from additional responsibilities. These components are described more fully below.

4.5.1 Inspection

Routine monitoring of forest retention and planted areas should occur a minimum of three times throughout the year to pinpoint any problems, monitor survival rates, and specify remedial actions needed to correct existing problems. [Appendix H](#) has examples of a forest inspection checklist and a reforestation inspection / completion certification report, an explanation of the forest inspection survival count procedure used by the Department of Recreation and Parks, and a forest survival count procedure used by the Maryland Department of Natural Resources. In the event that a developer experiences severe mortality on afforestation or reforestation sites, the Department of Recreation and Parks will be available to offer assistance in determining the cause.

The developer and their designee should conduct an inspection at the beginning of the second and third growing season to evaluate survival rates with reference to the survival required at the end of each growing season period. This is an opportunity to avoid the penalty for violating survival rate standards. This inspection should estimate survival potential based on the following:

- Vigor and threat of competing vegetation, including invasive exotic species
- Structure
- Growth rate
- Crown development
- Trunk health

4.5.2 Management of Forest Conservation Areas

Post-construction management of forest retention, reforestation and afforestation areas includes: maintenance of all fences, signs or other devices delineating forest conservation areas; needed watering; removal of dead or damaged material; control of undesirable competing species; thinning or pruning to encourage proper growth; fertilizing, if necessary; and control of pests.

Specific practices will depend on the weather prevailing during the post-construction period, the types of plant material and planting methods used, and specific site conditions, such as proximity to high use areas. It is the responsibility of the developer and their designee to take appropriate actions as needed. This Manual, therefore, does not cite required measures. Survival success, not fulfillment of a given series of tasks, will be the measure of conformance to the needs of the post-construction program.

If forest retention areas are damaged by ongoing site construction during the post-construction period, the following may be required:

- Stress reduction measures
- Tree or limb removal
- Replacement planting

Detailed information about managing forest retention areas and mitigating damage to them is provided in 4.2 Forest Retention Area Protection Procedures.

Newly planted trees, whether they are seedlings or 4" caliper transplants, have basic needs. Some of these needs can be met by nature alone; others may require human intervention. The three most likely causes of death for newly planted trees are drought, competing vegetation, and damage by deer and rodents. The basic maintenance regime should be determined by on-site environmental conditions, structure and nutrient content of the soil, and rainfall. Understanding these factors and the specific needs of the species and size of plants used will result in a healthy forested area at the end of the maintenance period. The previous section, Maintenance and Monitoring of Planted Areas, provides guideline specifications for maintenance of forest conservation areas and focuses on the following critical needs:

- Watering
- Fertilizing
- Controlling competing vegetation
- Protection from pests, diseases and mechanical injury

4.5.3 Replacement of Plant Material

If, after one growing season, the possibility exists that the original planting will not meet survival standards, the applicant should establish reinforcement plantings. Invasive exotic species will not count towards the survival tally and should be removed, but non-native species may count if approved for landscaping by DPZ. If plant mortality of reforestation or afforestation exceeds 10% of planted material at the end of the first growing season, replacement planting should be done to bring the total number of trees to 90% of the original total. Such material should be installed by the beginning of the second growing season. If at the end of the second growing season, the survival rate drops below 75%, such material as needed to guarantee a 75% survival rate should be installed. If at the end of the third growing season, the survival rate drops below 75%, such material as needed to guarantee a 75% survival rate at the time the surety is

scheduled for release should be installed.

If extensive replanting is needed to meet the 75% survival rate at the end of the third growing season, the maintenance period will be extended. If the survival rate is between 50% and 35%, then the maintenance period will be extended another season after the survival rate is brought back up to 75% by replanting. If the survival rate is 35% or lower, then the maintenance period will be extended another two seasons after the survival rate is brought back up to 75% by replanting.

4.5.4 Education of New Occupants

The occupants of a new development, whether owners or tenants, must avoid activities that destroy or degrade protected forest resources. The post-construction protection program must therefore include steps to educate the new occupants about the proper use of Forest Conservation Easement areas, about the need for the developer and their designee to carry out the post-construction protection program, the type and duration of the post-construction protection activities, and the eventual transfer of long-term responsibilities to the owners or occupants. Information conveyed to the new occupants should include the following:

- Copies of the Forest Conservation Plan or plat, locating all Forest Conservation Easement areas on the site.
- Letters or other written material explaining the developer's obligation for post-construction management, any rights of access needed to perform such duties, and a statement citing when new owners of the property or their common legal representative (for example, a homeowners association) will assume full responsibility for the Forest Conservation Easement areas. This material should include information about any future actions needed, such as the removal of tree shelters, to ensure continued forest health. This material should also include the list of permitted and prohibited activities within Forest Conservation Easement areas given in the Deed of Forest Conservation Easement.
- Signs posted on the property to delineate the Forest Conservation Easement areas.
- Other methods chosen by the developer.

The format and method of conveying such information is left to the discretion of the developer. Sample documents are available on the Department of Planning and Zoning website.

4.5.5 Final Inspection and Release of Obligations

At the end of the post-construction management and protection period, the Department of Planning and Zoning or its designee will conduct a final inspection to confirm that all Forest Conservation Easement areas have remained intact or have been restored to the appropriate condition after an encroachment, that the stipulated survival rates have been achieved, that the forest is healthy with no significant diseases or invasive exotic species, and that any permanent protection measures required by the Forest Conservation Plan are in place. At the end of the post-construction management and protection period, the applicant must submit to the Department of Planning and Zoning a written description of the steps taken to educate residents and/or business occupants of the subdivision or site about the proper use and protection of the Forest Conservation Easement areas, before the surety can be released. The County will notify the developer of the release of surety and all future obligations.

4.6 LONG-TERM PROTECTION RESPONSIBILITIES

To maintain the integrity of Forest Conservation Easement areas, the owners must refrain from any activities that would diminish the viability and environmental integrity of forest retention areas or hinder the growth and maturing of new forest plantings. When the site is occupied by tenants, the owner must ensure that the tenants do not, willfully or out of ignorance, use the site in ways that violate forest conservation restrictions or damage protected forest resources. Depending on the location, as well as the size and type of plant material, some maintenance is very beneficial, particularly in the early years. The Deed of Forest Conservation Easement (available from the Department of Public Works, Real Estate Services Division) contains a list of permitted and prohibited activities in Forest Conservation Easement areas. In all instances, State law requires that noxious weeds be controlled.

In many developments a homeowners association, tenants association or other management organization will maintain the site. Such a group is well suited to assume explicit responsibility for protecting the integrity of Forest Conservation Easement areas and performing any desired maintenance after the initial developer guarantees and obligations have expired. Responsibility for ensuring that all provisions of the Forest Conservation Easement are adhered to, however, ultimately belongs to the property owner(s).

CHAPTER 5: PROGRAM ADMINISTRATION

5.1 INTRODUCTION

This Chapter is intended to provide information for applicants and consultants on County procedures for administering the Forest Conservation Program. Information is given on the requirements for qualified professionals and the organization of the Program. Procedures are explained for processing various plans and permits, including major and minor subdivisions, site development plans, timber harvesting permits, capital improvement projects, linear projects and State funded highway projects. Procedures are also explained for establishing forest mitigation banks, and for establishing, relocating and abandoning Forest Conservation Easements. Information is also given on penalties for noncompliance with Program requirements.

5.2 QUALIFIED PROFESSIONALS

All Forest Conservation Plans, including Forest Stand Delineations, must be prepared and signed by a qualified professional. Proof of such qualification (license number, seal or DNR certificate) shall be part of the submission.

5.2.1 Required Background

Under County law only the following may prepare Forest Stand Delineations, Forest Conservation Plans or other required County Forest Conservation Program documents.

- A Maryland licensed forester.
- A Maryland licensed landscape architect.
- An ISA certified arborist who is also a State qualified professional.

State regulations (COMAR 08.19.06.01) set criteria by which professionals other than licensed foresters and landscape architects, primarily with natural resource or environmental planning backgrounds, are also considered qualified. However, a State qualified professional may not prepare the plans and the management programs required by the County Forest Conservation Program unless they also meet one of the three criteria listed above.

5.2.2 Responsibilities and Liability of Consultants

The consultant(s) responsible for preparation of a Forest Conservation Plan must assure that:

- The required Forest Stand Delineation is accurate.
- The retention, clearing, reforestation or afforestation areas shown on the plan are accurate and have been coordinated with other subdivision or site planning requirements to minimize loss of existing forest resources.
- The worksheet computations for retention, reforestation or afforestation, and the resultant cost estimate for the surety are accurate.
- Construction period protection measures have been coordinated with other construction activities and will be adequate to protect all forest retention and planting areas.
- Plant species, size, quantity and planting methods selected are appropriate to assure success for the existing and proposed site conditions.
- Post-construction protection measures, including neighbor education, are designed to achieve required survival rates.

Submission of inaccurate plans or information may constitute violations of the Program. Such violations may also result in suspension of qualifications to submit Forest Conservation Plans and related documents.

5.3 ORGANIZATION OF THE HOWARD COUNTY PROGRAM

Figure 5-A identifies the roles of the Department of Planning and Zoning, the Department of Public Works, the Department of Recreation and Parks, and the Howard Soil Conservation District in overall implementation of the Howard County Forest Conservation Program. It also enumerates the responsibilities of the Maryland Department of Natural Resources and Howard County Council in the process of enacting and implementing the Program.

5.4 REVIEW OF PLANS

The review of Forest Conservation Plans is intended to ensure that development proposals meet Forest Conservation Program requirements, along with other site development requirements. The Program administrator coordinates the review process, the Subdivision Review Committee coordinates interagency reviews, and pre-submission meetings help address any questions about Program applicability.

5.4.1 Program Administrator

As administrator of the subdivision and site development plan review process, the Department of Planning and Zoning shall coordinate review of Forest Conservation Plans with other requirements for approval of development proposals. These duties include:

- Meeting (upon request) with applicants and consultants to determine the optimal means for addressing the Program obligation associated with a specific development.
- Deciding on applicability or exemption from Forest Conservation Program requirements.
- Accepting Forest Stand Delineation and Forest Conservation Plan submissions as part of subdivision, site development or grading permit review submissions.
- Overseeing interagency review of plans and approving forest conservation proposals or suggesting resolution of conflicts between forest conservation proposals and other development proposal requirements, such as roads, utilities and stormwater management.
- Approving construction period and post-construction period management programs.
- Reviewing the Forest Conservation Agreement and the associated surety.
- Inspecting and verifying the developer's fulfillment of obligations as specified in the Forest Conservation Agreement.
- Authorizing the release of the Forest Conservation Agreement surety.
- Coordinating preparation of the Forest Conservation Deeds of Easement.
- Approving requests for payment of fee-in-lieu of reforestation or afforestation.

In addition to its plan review responsibilities, the Department of Planning and Zoning will also manage the other aspects of the Howard County Forest Conservation Program. Chief among these are data management to document how much forest is lost, retained or created by developments subject to the Program, and submission of all information needed for the required annual report and two-year review of local programs by DNR. In addition, the Department is responsible for managing the forest conservation fund, including processing defaults, collecting

all fines and fee-in-lieu of payments, and expending the fund for afforestation or reforestation planting or for the purchase of forest retention easements.

5.4.2 Interagency Review of Plans

The scope of the Forest Conservation Program and its complex relationship to other development requirements and to timber harvesting permit applications will involve other agencies in the review and enforcement of forest conservation requirements. Interagency review and coordination by the Subdivision Review Committee will ensure the compatibility of forest conservation proposals with other site development requirements, especially stormwater management, sediment and erosion control, grading, and open space requirements.

5.4.3 Pre-Submission Clarification

When the applicability of Forest Conservation Program requirements to a proposed subdivision or site development plan is not clear, the Department of Planning and Zoning strongly recommends a pre-submission meeting prior to formal submission. A pre-submission meeting requires: 1) a plan of the site showing existing forests, environmental features, probable limits of disturbance, and 2) a completed worksheet (see [Appendix C](#)) showing the likely impacts of the proposed subdivision or site development plan. Because this is only an informal screening, a qualified professional is recommended but not required to prepare these materials.

The applicant will be advised about the applicability of the Program, the likely obligation stemming from the Program requirements, the options available if different solutions are possible, and the Department's preference. This meeting is only for advisory purposes. It does not constitute approval of the material or options presented. To determine what should be submitted as part of this pre-submission review or to arrange a meeting, call the Department of Planning and Zoning at 410-313-2350.

5.5 MAJOR SUBDIVISION AND NONRESIDENTIAL SUBDIVISION PLAN PROCESS

A major subdivision is the division of a parcel of land into five or more residential lots. A nonresidential subdivision is the division of a nonresidentially zoned parcel of land into additional parcels. The plan review sequence for either type of subdivision is: sketch plan and preliminary plan or preliminary equivalent sketch plan, final plan and record plat, and site development plan, if required in accordance with the Subdivision and Land Development Regulations. At each plan stage, elements and refinements of the Forest Conservation Program are included for review and approval. Final plan review results in an approved Forest Stand Delineation and Forest Conservation Plan that will meet Program obligations. This process is described more fully in [Figure 5-B](#).

5.6 MINOR SUBDIVISION PLAN PROCESS

A minor subdivision is the division of a residentially zoned property into four or fewer residential lots. The property may be subdivided into these residential lots at one time or through the recordation of multiple subdivision plats. When determining if a proposed subdivision is a minor subdivision, an examination must be made of the total number of residential lots created from the original parcel by recorded subdivision plat.

A minor subdivision that will meet Program obligations through on- or off-site retention or

planting, must submit a Forest Stand Delineation (FSD) and Forest Conservation Plan (FCP). The FSD and FCP must be approved prior to recordation of the plat creating the lots and Forest Conservation Easements. If DPZ approves payment of a fee-in-lieu to meet Program obligations, the application must include the plat, an FSD and a Forest Conservation Worksheet, to determine the amount of fee-in-lieu payment. [Figure 5-C](#) provides more detail on the process for a minor subdivision.

5.7 OTHER PLAN AND PERMIT PROCESSES

The following describes the plan review process for site development plans, timber harvesting plans, Howard County capital improvement projects, linear projects, State funded highway projects and grading/building permits on single residential lots.

5.7.1 Site Development Plan

A site development plan is required for a new or expanded nonresidential development (commercial, industrial, institutional or public facility), and for certain residential development, and may be used to provide the design for a forest mitigation bank. A site development plan submission for a nonresidential development and for a forest mitigation bank must include a Forest Stand Delineation and a Forest Conservation Plan. A residential development will also need an FSD and FCP, unless the project met forest conservation obligations at the subdivision stage. [Figure 5-D](#) provides more detail on the process for a site development plan.

5.7.2 Timber Harvesting Plan

The timber harvesting process may precede a subdivision or site development plan proposal, or may be a stand alone harvest that occurs independently of a development project. A timber harvesting plan will not be approved for the cutting or clearing of land that is in the subdivision or site development plan review process until the Forest Stand Delineation and Forest Conservation Plan are determined to be technically complete, thereby establishing the Forest Conservation Easement boundaries. A timber harvesting plan for a stand alone timber harvest must include a Declaration of Intent. [Figure 5-E](#) provides more detail on the review process for a timber harvesting plan.

5.7.3 Howard County Capital Improvement Project

It is the County's responsibility to determine forest conservation requirements for its capital improvement projects such as schools, utilities and roads, except for State funded highways. This policy applies even if a County capital budget project has partial State funding. The Department of Planning and Zoning will review and provide written comments concerning forest conservation requirements and, in most instances, will submit the project to the Subdivision Review Committee. For all capital improvement projects, the Department of Planning and Zoning should be contacted as soon as possible if there are any questions about the applicability of forest conservation requirements or which agency will be responsible for review. [Figure 5-F](#) provides more detail on this process.

5.7.4 Linear Project

A linear project has an elongated configuration with nearly parallel sides. These projects are used to transport a utility product or provide a public service, such as electricity, gas, water, sewer, communications or transportation, that are not otherwise contained in an application for subdivision. These projects may traverse fee simple properties through defined boundaries, or through easements or access rights. The procedure for a State funded highway project is

discussed separately in the following section. [Figure 5-G](#) provides more detail on the linear project review process.

5.7.5 State Funded Highway Project

A State funded highway project will be reviewed by the Maryland Department of Natural Resources under Natural Resources Article Section 5-103. As interpreted by the State, a State funded highway project is any roadway construction that has any State funding.

5.7.6 Grading/Building Permit on Single Residential Lot

The following process will be used for grading or construction activity on a single residential lot or parcel of 40,000 square feet or greater where:

1. The forest conservation obligation was not previously addressed through the subdivision or site development plan processes;
2. The applicant is cutting or clearing 20,000 square feet or more of forest; and
3. Placement of forest conservation easements on the lot or parcel does not meet the requirement of Section 16.120(b)(4)(iii) of the Subdivision and Land Development Regulations, which prohibits forest conservation easements on a lot or buildable preservation parcel of less than ten acres.

This situation will most often occur when the lot or parcel is entirely or predominantly wooded.

The applicant must submit a combined Forest Stand Delineation and Forest Conservation Plan, and may apply for a variance to Section 16.120(b)(4)(iii) to allow meeting their forest conservation obligation on-site. This on-site obligation will be met by placing retention easements on forest in high priority areas to meet the break even point, the point at which forest conservation obligations can be met by retention only.

If the lot or parcel is part of a previously recorded subdivision, the easements must be created by a Plat of Revision. Otherwise, the easements may be created by deed, in lieu of a standard Plat of Easement. If the break even point is not met, any remaining obligation should be met off-site or through a mitigation bank. If there are no available credits in a mitigation bank, the applicant may request payment of a fee-in-lieu. If the remaining obligation is greater than one acre, the applicant may also need to apply for a variance to Section 16.1209(a)(2) of the Subdivision and Land Development Regulations.

5.8 MITIGATION BANK

To provide the necessary planting or retention details for establishing a mitigation bank, the owner/developer usually must submit a site development plan (SDP) that includes a Forest Stand Delineation and a Forest Conservation Plan. Alternatively, the bank may be shown on a final road construction plan, if it is proposed on a site in process of subdivision and the subdivision plan includes a Forest Conservation Plan. The SDP or road construction plan will track the sale of credits from the bank and must be red-lined (changes to the approved plans are shown in red) each time credits are transferred. [Figure 5-H](#) provides more detail on the steps for establishing a mitigation bank.

Once a bank has been established through the recordation of the plat, the execution of the legal documents, the posting of any required surety, the approval of the SDP or final road construction plan, and the completion of planting, the forest credits are eligible for sale. Planted banks may sell credits to developers at a ratio of 1 acre of forest planted for every 1 acre of forest conservation obligation. When a developer patronizes a retention bank, 2 acres of forest

retention credits are needed for every 1 acre of forest conservation obligation the developer wishes to fulfill.

After the owner/developer has installed the approved plant materials and/or retention devices, the County will conduct an inspection to verify that the planting and other measures have been installed in accordance with the approved SDP or final road construction plan. After the bank has passed initial inspection, the three growing season minimum survival period for the planted or retention bank begins.

5.9 INSPECTION AND ENFORCEMENT

Close interagency cooperation is needed for inspection and enforcement, especially during the construction period, when forest retention, reforestation and afforestation areas are most susceptible to stress and degradation from site disturbances.

Enforcement of the approved limits of disturbance is a primary concern. Inspections of forest limits are most likely to occur in tandem with inspections for other environmental requirements, such as installation and maintenance of sediment and erosion control structures, and inspections to ensure that floodplain, wetland, steep slope or stream buffer areas are being protected. The applicant or their designee will be obliged to ensure that all forest retention areas are properly protected, and that all reforestation and afforestation planting requirements (species, size, number and planting methods), and any other horticultural or forest management measures cited in the approved Forest Conservation Plan (FCP) are carried out as specified.

The Construction Inspection Division of the Department of Public Works is responsible for the inspection of a site prior to the commencement of construction activities, and during construction to ensure that all required protective devices are in place, and that the approved Limit of Disturbance is clearly designated and respected.

The Departments of Planning and Zoning (DPZ) and Recreation and Parks are responsible for inspecting and verifying that all retention and planting are done in accordance with the approved FCP. For each subdivision or site development plan creating Forest Conservation Easements, DPZ establishes and enforces an inspection schedule based on the execution date of the Forest Conservation Agreement (or based on written communication from the developer in the event that the obligation has been fulfilled at an earlier date). DPZ is responsible for monitoring each project's completion schedule to ensure that a developer meets the forest conservation obligation consistent with the approved FCP and in a timely manner.

In response to notification by DPZ, the Department of Recreation and Parks (DRP) conducts site inspections at the following times: to initiate the three growing season post-construction maintenance period; at the end of the three growing season post-construction maintenance period; prior to the authorization for surety release; and, if necessary, prior to the initiation of default proceedings by the County. DRP also assists DPZ by inspecting sites to ascertain the extent and nature of encroachments and other violations in Forest Conservation Easements, to issue violation notices regarding those encroachments, and to make recommendations and oversee their implementation for remediation of these adverse impacts. At the request of DPZ, the Department of Recreation and Parks also performs site inspections to determine if individual trees within Forest Conservation Easements pose safety hazards relative to the homes or businesses located adjacent to those easements. DRP will grant permission for removal of individual trees determined to be a safety hazard.

5.10 NONCOMPLIANCE AND PENALTIES

Failure to submit a required Forest Conservation Plan or to adhere to the requirements of an approved Forest Conservation Plan prior to the commencement of regulated activities, will result in possible noncompliance and civil fines, institution of a stop work order or injunction, requirements to restore or create forest communities lost through noncompliance, or any combination of these penalties. Fines are established in the fee schedule adopted annually by the County Council. There are several categories of noncompliance, each with its own penalties.

1. **Failure to submit or comply with a Declaration of Intent.** Failure to file a required Declaration of Intent may result in a civil penalty. Engaging in a development activity regulated by the Forest Conservation Program within five years of the effective date of period following the conclusion of activities specified in the Declaration of Intent makes the offender liable to the requirements for reforestation or afforestation based on the original forest cover.
2. **Failure to submit a required Forest Conservation Plan.** Conducting any regulated activity without an approved Forest Conservation Plan will result in civil and/or noncompliance penalties and mitigation to restore the forest resources cleared by such unauthorized actions.
3. **Failure to adhere to the conditions of an approved Forest Conservation Plan.** Such violations can occur during the construction period, during the three growing season minimum post-construction management period, or after transfer of the forest conservation restrictions and responsibilities to future owners of the property.

During the construction and post-construction maintenance periods, the developer is liable. Civil and/or noncompliance penalties and/or mitigation of damage incurred are all possible. If the County determines that a site is not in compliance with the approved Forest Conservation Plan at the end of the post-construction period, the County has the authority to default the bond and to complete the developer's obligation, or to extend the Forest Conservation Agreement until compliance has been achieved. The County may also require that the Forest Conservation Agreement be amended to increase the surety amount to current fee schedule rates and to add a specific date for completion of the forest conservation obligations. If a change in surety is required, the developer is responsible for all processing fees associated with the modification to the Forest Conservation Agreement. The post-construction management surety may be extended, as appropriate, for any mitigation work required to correct noncompliance.

Subsequent property owners assume full responsibility for maintaining the integrity of forest retention, reforestation and afforestation areas under the terms of the Forest Conservation Easement. Degradation or destruction of such areas may result in monetary penalties and/or mitigation to restore these areas to a quality acceptable to the County.

5.11 FOREST CONSERVATION EASEMENT

The forest retention, reforestation and afforestation areas created by an approved Forest Conservation Plan must be permanently protected and recorded as a Forest Conservation Easement. The Forest Conservation Easement must be clearly delineated and properly dimensioned on a record plat or a plat of Forest Conservation Easement, designated on the construction drawings, and marked with explanatory signage in the field. The easement is accompanied by a Forest Conservation Agreement and a Deed of Forest Conservation Easement, which further define the care and protection of the forest within the easement. These

restricted areas are comparable to floodplains, wetlands or drainage easements, whose integrity must be respected and maintained by all future owners. For this reason, placement of Forest Conservation Easements on private residential lots is undesirable. When Forest Conservation Easements are approved on private lots, lot use will be limited, as specified in the Subdivision and Land Development Regulations.

5.12 FOREST CONSERVATION AGREEMENT

The Forest Conservation Agreement describes how the developer will retain, plant, manage and protect the forest in the Forest Conservation Easement, in accordance with the approved Forest Conservation Plan. The agreement specifies when certain activities should occur during the development process, what actions constitute a default on the agreement, and allowable remedies for the County. The agreement is secured by a surety for reforestation and afforestation areas that is released at the end of the minimum three growing season maintenance period, if a final inspection confirms that all forest conservation obligations have been met.

5.13 ABANDONMENT OR RELOCATION OF RECORDED EASEMENTS

The following sections define abandonment and relocation of a recorded easement, and explain the procedure for each.

5.13.1 Abandonment

It may be appropriate under certain circumstances to abandon a recorded Forest Conservation Easement when an error or encroachment has occurred and the area within the easement no longer complies with the Forest Conservation Act. These circumstances can include:

- An easement or property line boundary, or property ownership error was made in the delineation or recordation of the easement.
- The delineation of the easement included a structure or utility that was discovered after the easement was recorded.
- An encroachment occurred within the easement, such as the construction of a building or parking lot, and the area cannot reasonably be restored to a healthy forest.

Requests to abandon a recorded easement must be made in writing to the Department of Planning and Zoning. The request must include an explanation as to why the abandonment is needed, and how an equivalent replacement for the abandoned acreage will be provided. The replacement easement shall be at a minimum equal to the abandoned easement in acreage.

The easement should be replaced in kind on site, but if this is not feasible, the easement should be replaced by creating an off-site easement adjacent to an existing FCE or by purchase of credits from a forest mitigation bank. If the replacement location is outside the original easement watershed, the replacement acreage will be based on an outside the watershed mitigation ratio of 3:1. If credits are not available in a mitigation bank, replacement may be provided through payment of a fee-in-lieu. The fee-in-lieu will be based on the outside the watershed mitigation acreage and will be assessed on a square foot basis at a rate published in the County Council annual Fee Schedule. This fee will include both the standard fee-in-lieu and an abandonment penalty. Please note that abandonment of 0.5 acres or less can be approved administratively by DPZ, but abandonment over 0.5 acres will be submitted to the County Council for approval.

5.13.2 Relocation

Pursuant to Section 16.1204(d)(10), it may be appropriate in certain circumstances, to relocate a recorded Forest Conservation Easement, as a result of changes in a development or condition of the site. Such circumstances can include:

- A change in site design for a development in process.
- A change in the condition of the site.
- The need to provide new or expand existing utilities or other infrastructure, such as a new sewer line or stormwater management facility, or a roadway widening.

Requests to relocate a recorded easement must be made in writing to the Department of Planning and Zoning. The request must include an explanation as to the alternatives considered, why the relocation is needed and how an equivalent replacement for the easement acreage will be provided.

An equivalent replacement easement will be evaluated, based on the following criteria.

- The replacement easement must be at a minimum equal to the original easement in acreage.
- The forest in the replacement easement should be of similar or better quality in terms of age and health as in the original easement.
- In order of preference, the replacement easement should be located on the original easement property, or within the original easement watershed in a mitigation bank or off-site location.
- The replacement easement should be located in accordance with the priority retention or planting areas, as specified in Chapter 3.

If the replacement location is outside the original easement watershed, the minimum replacement acreage will be based on an outside the watershed mitigation ratio of 3:1. Only if credits are not available in a mitigation bank, may replacement be provided through payment of a fee-in-lieu, which will be based on the outside the watershed mitigation acreage. The fee-in-lieu rate will be assessed on a square foot basis at a rate published in the County Council annual Fee Schedule.

5.13.3 Procedure

If the relocation or abandonment of the recorded Forest Conservation Easement is approved, the Department of Planning and Zoning will issue written instructions to the applicant outlining how to implement the proposal. If the easement will be abandoned, the applicant must provide public notice in accordance with a template provided by DPZ once a week for three successive weeks in at least one newspaper of general circulation in the County.

The applicant must process a Plat of Revision or a Plat of Forest Conservation Easement, which upon recordation will supersede the plat of record. If the preceding plat that established the Forest Conservation Easement was a subdivision plat, a Plat of Revision will be required. If the preceding plat was a Plat of Forest Conservation Easement, an Amended Plat of Forest Conservation Easement will be required. In addition, for any easement abandonment or relocation, the applicant must execute an amended Deed of Forest Conservation Easement with the Department of Public Works, Real Estate Services Division. It will also be necessary to re-line the associated road construction plans, site development plan and/or Forest Conservation Plan to reflect the easement alteration. It may also be necessary for the applicant to amend the Forest Conservation Agreement and to adjust the posted surety. If the abandoned or relocated

easement is replaced off-site, the applicant will also need to process a Plat of Forest Conservation Easement or a Plat of Revision for the proposed site.

5.14 FOREST CONSERVATION FUND

The Department of Planning and Zoning will also be responsible for use of the forest conservation fund established by the Program as the repository of all fines and fee-in-lieu of payments collected.

The minimum in-lieu fees established by State law will only be used to: purchase, prepare and plant new forest stands on appropriate sites, or purchase retention easements; maintain existing forests; and achieve urban canopy goals. The County may use the forest conservation fund to purchase permanent forest retention easements only on private property that is not recorded open space or is not subject to an existing preservation easement. Fines and in-lieu fees collected at rates exceeding the required minimum levies established by State law may be used for other Forest Conservation Program functions (public education, planning, training of staff), as appropriate. The fund can also accept grants, donations or other appropriations to help fund the overall operations of the Forest Conservation Program and to increase the amount of forest created through the Program. Such funds may also be used for any Forest Conservation Program functions deemed appropriate.

Eligible sites for forest conservation fund implementation of reforestation or afforestation can include County-owned open space, private open space, properties with environmental easements, appropriate land in agricultural easements, preservation parcels created by rural clustering, or private properties for which reforestation agreements can be negotiated. Owners of private properties to be used for such plantings must agree to have the areas and terms of forest conservation restrictions recorded as deed restrictions, to provide areas of at least 50-foot minimum width and 10,000 square feet for such plantings, and grant legal rights of access for any necessary site preparation, planting and post-planting management and inspection. The creation of a Forest Conservation Easement on any property requires the recordation of a plat (subdivision, revision or easement plat).

5.15 ACCOUNTABILITY TO THE STATE

The Department of Planning and Zoning shall be the chief liaison between Howard County and the Maryland Department of Natural Resources (DNR). This liaison role includes preparing annual reports on accomplishments of the Program, cooperating with DNR during DNR's two-year review of local programs, notifying DNR of requests for variances, forwarding to DNR for its review any public project involving State funding, and assisting DNR in its inventory of Howard County forest resources. Applications for variances of the Forest Conservation Program requirements shall be forwarded to DNR within 15 days of receipt by DPZ. Applications for variances to defer, phase or seek alternative compliance with the Forest Conservation Program requirements shall be forwarded to DNR after a decision is rendered by DPZ.

Figure 5-A: Program Administration Responsibilities

Department of Planning and Zoning

- Administers Program.
- Coordinates review of Forest Conservation Plan submissions with other development review submissions and timber harvesting permit applications.
- Coordinates with the Department of Recreation and Parks and the Office of Community Sustainability to evaluate variance requests.
- Coordinates inspections of forest retention and planting areas for compliance with the approved Forest Conservation Plan and authorizes release of financial guarantees.
- Administers use of forest conservation fund.
- Acts as main liaison to DNR.
- Coordinates with the Office of Law, and the Departments of Recreation and Parks and Public Works to address compliance violations and developer defaults.

Department of Public Works

- Prepares the Forest Conservation Agreement and the Deed of Forest Conservation Easement.
- Oversees the posting of required sureties and execution of required documentation.
- Performs inspection for enforcement of the approved limit of disturbance in conjunction with sediment and erosion control inspections.

Department of Recreation and Parks

- Evaluates variance requests in coordination with the Department of Planning and Zoning and Office of Community Sustainability.
- Evaluates on-site reforestation/afforestation for open space land proposed to be dedicated to the County.
- Reviews plans for off-site planting on public property.
- Assists the Department of Planning and Zoning in resolution of unauthorized encroachments and other violations in Forest Conservation Easements.
- Advises developers about site preparation, particularly invasive species control, and management of planted areas to ensure survival.
- Conducts site inspections to monitor compliance with the approved Forest Conservation Plan.
- Maintains a geographic information system database of all Forest Conservation Easements.
- Designs and implements forest conservation plantings for defaulted projects.

Howard Soil Conservation District

- Reviews Forest Conservation Plans for compatibility with sediment and erosion control regulations.
- Provides technical advice on forest conservation issues related to soil issues.
- Approves timber harvesting permits that are exempt from or conform to an approved Forest Conservation Plan.

Office of Community Sustainability

- Evaluates variance requests in coordination with the Department of Planning and Zoning and Department of Recreation and Parks.

Howard County Council

- Approves Howard County forest conservation regulations, manual and fee schedule.

Maryland Department of Natural Resources

- Issues regulations and criteria to be incorporated in local programs.
- Reviews and approves local program every 2 years.
- Develops forest resource maps to assist in location of potential reforestation and afforestation sites.
- Reviews local government projects when State funds are involved.
- Receives notice of variance requests.
- Receives annual reports from local governments on progress of forest conservation program and submits to Maryland General Assembly.

Figure 5-B: Major Subdivision and Nonresidential Subdivision Plan Process

Subdivision and Site Development Stages	Forest Conservation Requirements/Actions	Responsible Party
1. Sketch Plan	<p>Forest Stand Delineation (FSD)</p> <ul style="list-style-type: none"> a. Prepare and submit FSD with the sketch plan (non-signature sheet). b. Review and verify delineation. c. Identify priority retention areas for on-site retention. 	<p>A</p> <p>A and SRC</p> <p>A and SRC</p>
2. Preliminary Plan	<p>Preliminary Forest Conservation Plan (FCP)</p> <ul style="list-style-type: none"> a. Prepare and submit with the preliminary plan, a preliminary FCP design (signature sheet) and worksheet with written justification for locating Forest Conservation Easements (FCE), for clearing, requests for off-site retention or planting, and fee-in-lieu. b. Coordinate FCP concept with lot layout, road design, open space, utility location and stormwater management design. c. Verify consistency between FCP sheets, grading and sediment and erosion control sheets, and landscape plan requirements. d. Provide a construction phasing schedule. e. Review FCP, worksheet, justification statements and consistency among various sheets. 	<p>A</p> <p>A and SRC</p> <p>A and SRC</p> <p>A</p> <p>A and SRC</p>
3. Preliminary Equivalent Sketch Plan	<p>FSD and Preliminary FCP</p> <ul style="list-style-type: none"> a. Address requirements of both the sketch plan stage and the preliminary plan stage. 	<p>A and SRC</p>

A = Applicant
 DPZ = Department of Planning and Zoning
 DPW = Department of Public Works
 SRC =Subdivision Review Committee

Subdivision and Site Development Stages	Forest Conservation Requirements/Actions	Responsible Party
4. Final Plan	<p>Final FCP and Plat</p> <ul style="list-style-type: none"> a. Prepare and submit final FCP (signature sheet) in final plans. b. Coordinate final FCP with construction plans, sediment & erosion control plans, landscape plan, and plat; provide notes re: acreage of FCE and surety. c. Execute Forest Conservation Agreement and post surety. d. Record FCE boundaries shown on final plan on the record plat. e. Record all permanent forest conservation restrictions and responsibilities, including legal right of access to off-site retention or planting areas (Deed of Forest Conservation Easement). f. Submit and enter into County records a completed Forest Conservation Data Sheet with final plat originals. 	<p>A</p> <p>A and SRC</p> <p>A and DPW A and DPZ</p> <p>A, DPZ and DPW</p> <p>A and DPZ</p>
5. Construction	<ul style="list-style-type: none"> g. Provide written notice to nearby residents and business occupants about the proper use and protection of the Forest Conservation Easement areas. h. Install all required protection measures. i. Inspect and enforce limits of disturbance and required protection measures. j. Plant for reforestation/afforestation. k. Coordinate forest retention or planting with landscaping. l. Inspect for compliance with FCP. 	<p>A</p> <p>A</p> <p>A, DPW and DRP</p> <p>A</p> <p>A, DPZ and DRP</p> <p>A and DRP</p>
6. Post-Construction	<ul style="list-style-type: none"> a. Provide written notice to nearby residents and business occupants about the proper use and protection of the Forest Conservation Easement areas. b. Begin minimum 3 growing season maintenance period. c. Inspect after each growing season and replace plantings as required. d. Inspect to determine that final survival rates have been met. e. Authorize and release surety. f. Transfer long term responsibility to future owners (if not original owner/developer). 	<p>A</p> <p>A, DRP and DPZ</p> <p>A</p> <p>A and DRP</p> <p>DPZ and DPW</p> <p>A</p>

A = Applicant
DPZ = Department of Planning and Zoning
DPW = Department of Public Works
DRP = Department of Recreation and Parks
SRC = Subdivision Review Committee

Figure 5-C: Minor Subdivision Plan Process

Subdivision and Site Development Stages	Forest Conservation Requirements/Actions	Responsible Party
1. Minor Subdivision Application with Forest Conservation Easements	<ul style="list-style-type: none"> a. Prepare and submit Forest Stand Delineation jointly with Forest Conservation Plan (FCP) (signature sheet). Designate retention and planting areas, show limit of disturbance, and specify protection measures. b. Review and approve proposal. 	<p>A</p> <p>SRC</p>
2. Recordation	<ul style="list-style-type: none"> a. Execute Forest Conservation Agreement (developer's agreement) and post surety. b. Record Forest Conservation Easement boundaries on plat and record Deed of Forest Conservation Easement. 	<p>A and DPW</p> <p>A, DPZ and DPW</p>
3. Construction	<ul style="list-style-type: none"> a. Provide written notice to nearby residents and business occupants about the proper use and protection of the Forest Conservation Easement areas. b. Install all required protection measures. c. Inspect and enforce limits of disturbance and required protection measures. d. Plant for reforestation/afforestation. e. Coordinate forest retention or planting with landscaping. f. Inspect for compliance with FCP. 	<p>A</p> <p>A</p> <p>A and DRP</p> <p>A</p> <p>A, DPZ and DRP</p> <p>A and DRP</p>
4. Post-Construction	<ul style="list-style-type: none"> a. Provide written notice to nearby residents and business occupants about the proper use and protection of the Forest Conservation Easement areas. b. Begin minimum 3 growing season maintenance period. c. Inspect after each growing season and replace plantings as required. d. Inspect to determine that final survival rates have been met. e. Authorize and release surety. f. Transfer long term responsibility to future owners (if not original owner/developer). 	<p>A</p> <p>A, DPZ and DRP</p> <p>A</p> <p>A and DRP</p> <p>DPZ and DPW</p> <p>A</p>

A = Applicant
 DPZ = Department of Planning and Zoning
 DRP = Department of Recreation and Parks
 DPW = Department of Public Works
 SRC = Subdivision Review Committee

Subdivision and Site Development Stages	Forest Conservation Requirements/Actions	Responsible Party
1. Minor Subdivision Application without Forest Conservation Easements	<ul style="list-style-type: none"> a. Prepare and submit Forest Stand Delineation jointly with Forest Conservation Worksheet to determine the forest conservation obligation. b. Secure credits in a mitigation bank to meet forest conservation obligation. c. If credits are not available, determine amount of fee-in-lieu payment, and submit written justification for fee-in-lieu payment. d. Review and approve proposal. e. Pay fee-in-lieu, if applicable. 	<p>A</p> <p>A</p> <p>A</p> <p>SRC</p> <p>A and DPZ</p>

A = Applicant

DPZ = Department of Planning and Zoning

SRC = Subdivision Review Committee

Figure 5-D: Site Development Plan Process

Subdivision and Site Development Stages	Forest Conservation Requirements/Actions	Responsible Party
1. Site Development Plan	<ul style="list-style-type: none"> a. If forest conservation obligations have not been addressed previously during subdivision, prepare and submit Forest Stand Delineation jointly with Forest Conservation Plan (FCP) (signature sheet). Designate retention and planting areas, show limit of disturbance, and specify protection measures. b. Review and approve proposal. 	<p>A</p> <p>SRC</p>
2. Recordation	<ul style="list-style-type: none"> a. Execute Forest Conservation Agreement (developer's agreement) and post surety. b. Record Forest Conservation Easement boundaries on plat and record Deed of Forest Conservation Easement. 	<p>A and DPW</p> <p>A, DPZ and DPW</p>
3. Construction	<ul style="list-style-type: none"> a. Provide written notice to nearby residents and business occupants about the proper use and protection of the Forest Conservation Easement areas. b. Install all required protection measures. c. Inspect and enforce limits of disturbance and required protection measures. d. Plant for reforestation/afforestation. e. Coordinate forest retention or planting with landscaping. f. Inspect for compliance with FCP. 	<p>A</p> <p>A</p> <p>A and DRP</p> <p>A</p> <p>A, DPZ and DRP</p> <p>A and DRP</p>
4. Post-Construction	<ul style="list-style-type: none"> a. Provide written notice to nearby residents and business occupants about the proper use and protection of the Forest Conservation Easement areas. b. Begin minimum 3 growing season maintenance period. c. Inspect after each growing season and replace plantings as required. d. Inspect to determine that final survival rates have been met. e. Authorize and release surety. f. Transfer long term responsibility to future owners (if not original owner/developer). 	<p>A</p> <p>A, DPZ and DRP</p> <p>A</p> <p>A and DRP</p> <p>DPZ and DPW</p> <p>A</p>

A = Applicant
 DPZ = Department of Planning and Zoning
 DRP = Department of Recreation and Parks
 DPW = Department of Public Works
 SRC = Subdivision Review Committee

Figure 5-E: Timber Harvesting Plan Process

Subdivision and Site Development Stages	Forest Conservation Requirements/Actions	Responsible Party
1. Timber Harvest Plan for a Stand Alone Harvest	<ul style="list-style-type: none"> a. Prepare and submit a Declaration of Intent (DOI) for Forestry Activities to the Department of Planning and Zoning (DPZ). b. Review and approve the DOI. c. Complete and submit a Compliance Agreement for Standard Erosion and Sediment Control Plan for Forest Harvest Operations to HSCD. d. Review and approve the Compliance Agreement for Standard Erosion and Sediment Control Plan for Forest Harvest Operations and assign a Grading Permit Number. e. Submit the grading permit to the Department of Inspections, Licenses and Permits and DPZ for review. f. Review and approve the grading permit. 	<p>A</p> <p>DPZ A</p> <p>HSCD</p> <p>A</p> <p>DILP and DPZ</p>

A = Applicant
DILP = Department of Inspections, Licenses and Permits
DPZ = Department of Planning and Zoning
HSCD = Howard Soil Conservation District

Subdivision and Site Development Stages	Forest Conservation Requirements/Actions	Responsible Party
1. Timber Harvest Plan for a Harvest Associated with a Development Proposal.	<ul style="list-style-type: none"> a. The applicant must follow the procedure for the applicable plan process to prepare and submit a Forest Stand Delineation jointly with a Forest Conservation Plan. b. Review and make determination that the Forest Stand Delineation and Forest Conservation Plan are technically complete. c. Complete and submit a Compliance Agreement for Standard Erosion and Sediment Control Plan for Forest Harvest Operations to HSCD. d. Review and approve the Compliance Agreement for Standard Erosion and Sediment Control Plan for Forest Harvest Operations and assign a Grading Permit Number. e. Submit the grading permit to the Department of Inspections, Licenses and Permits and DPZ for review. f. Review and approve the grading permit. 	<p>A</p> <p>DPZ</p> <p>A</p> <p>HSCD</p> <p>A</p> <p>DILP and DPZ</p>

A = Applicant
DILP = Department of Inspections, Licenses and Permits
DPZ = Department of Planning and Zoning
HSCD = Howard Soil Conservation District

Figure 5-F: County Capital Improvement Project Process

Subdivision and Site Development Stages	Forest Conservation Requirements/Actions	Responsible Party
1. Construction Drawing	<ul style="list-style-type: none"> a. Prepare and submit Forest Stand Delineation jointly with Forest Conservation Plan (FCP) (signature sheet) designating retention, reforestation and afforestation areas, and planting specifications. Coordinate with all construction plans, show limit of disturbance and specify protection measures needed. b. Review and approve proposal. 	<p>A</p> <p>SRC</p>
2. Recordation	<ul style="list-style-type: none"> a. Execute Forest Conservation Agreement and post surety. b. Record Forest Conservation Easement boundaries on plat and record Deed of Forest Conservation Easement. 	<p>A and DPW A, DPZ and DPW</p>
3. Construction	<ul style="list-style-type: none"> a. Provide written notice to nearby residents and business occupants about the proper use and protection of the Forest Conservation Easement areas. b. Install all required protection measures. c. Inspect and enforce Limits of Disturbance and required protection measures. d. Plant for reforestation/afforestation. e. Coordinate forest retention or planting measures with other required landscaping. f. Inspect for compliance with approved FCP. 	<p>A</p> <p>A</p> <p>A and DRP</p> <p>A</p> <p>A, DPZ and DRP</p> <p>A and DRP</p>
4. Post- Construction	<ul style="list-style-type: none"> a. Provide written notice to nearby residents and business occupants about the proper use and protection of the Forest Conservation Easement areas. b. Begin minimum 3 growing season maintenance period. c. Inspect after each growing season and replace plantings as required. d. Inspect and verify that final survival rates have been achieved. e. Authorize and release surety. f. Transfer long-term responsibility to future owners (if not original owner/developer). 	<p>A</p> <p>A, DPZ and DRP</p> <p>A</p> <p>A and DRP DPZ and DPW A</p>

A = Applicant
 DPZ = Department of Planning and Zoning
 DRP = Department of Recreation and Parks
 DPW = Department of Public Works
 SRC = Subdivision Review Committee

Figure 5-G: Linear Project Process

Subdivision and Site Development Stages	Forest Conservation Requirements/Actions	Responsible Party
1. Site Development Plan	<ul style="list-style-type: none"> a. Prepare and submit Forest Stand Delineation jointly with a Forest Conservation Plan (FCP) (signature sheet) designating retention, reforestation and afforestation areas, and planting specifications. Coordinate with all construction plans, show limit of disturbance area and specify protection measures needed. b. Review and approve proposal. 	<p>A</p> <p>SRC</p>
2. Recordation	<ul style="list-style-type: none"> a. Execute Forest Conservation Agreement and post surety. b. Record Forest Conservation Easement boundaries on plat and record Deed of Forest Conservation Easement. 	<p>A and DPW</p> <p>A, DPZ and DPW</p>
3. Construction	<ul style="list-style-type: none"> a. Provide written notice to nearby residents and business occupants about the proper use and protection of the Forest Conservation Easement areas. b. Install all required protection measures. c. Inspect and enforce Limits of Disturbance and required protection measures. d. Plant for reforestation/afforestation. e. Coordinate forest retention or planting measures with other required landscaping. f. Inspect for compliance with approved FCP. 	<p>A</p> <p>A</p> <p>A and DRP</p> <p>A</p> <p>A, DPZ and DRP</p> <p>A and DRP</p>
4. Post- Construction	<ul style="list-style-type: none"> a. Provide written notice to nearby residents and business occupants about the proper use and protection of the Forest Conservation Easement areas. b. Begin minimum 3 growing season maintenance period. c. Inspect after each growing season and replace plantings as required. d. Inspect and verify that final survival rates have been achieved. e. Authorize and release surety. f. Transfer long-term responsibility to future owners (if not original owner/developer). 	<p>A</p> <p>A, DPZ and DRP</p> <p>A</p> <p>A and DRP</p> <p>DPZ and DPW</p> <p>A</p>

A = Applicant
 DPZ = Department of Planning and Zoning
 DPW = Department of Public Works
 DRP = Department of Recreation and Parks
 SRC = Subdivision Review Committee

Figure 5-H: Mitigation Bank Process

Subdivision and Site Development Stages	Forest Conservation Requirements/Actions	Responsible Party
1. Site Development Plan or Final Road Construction Plan, and Forest Conservation Plan	a. Prepare and submit a site development plan (SDP) or final road construction plan, a Forest Stand Delineation and Forest Conservation Plan (FCP) (signature sheet), and a Plat of Forest Conservation Easement (for deeded sites) or Plat of Revision (for previously subdivided sites). b. Review and approve proposal.	A SRC
2. Recordation	a. Execute the Forest Conservation Agreement and post surety, if establishing a mitigation planting bank. An agreement and surety are not required to establish a retention bank; however, signage must be installed and education of nearby residents documented. b. Prepare the Deed of Forest Conservation Easement. c. Approve the plat and SDP or final road construction plan. d. Record Plat of Forest Conservation Easement or Plat of Revision, and Deed of Forest Conservation Easement.	A and DPW DPW SRC A, DPZ and DPW
3. Planting	a. Provide written notice to nearby residents and business occupants about the proper use and protection of the Forest Conservation Easement areas. b. Install approved plant materials. c. Inspect for completion of required FCP plantings and installation of required retention devices. d. Begin minimum 3 growing season maintenance period. e. Inspect after each growing season and replace plantings as required. f. Inspect to determine that final survival rates have been met. g. Authorize and release surety. h. Transfer long term responsibility to future owners (if not original owner/developer).	A A A and DRP A, DPZ and DRP A A and DRP DPZ and DPW A
4. Sale of Credits	a. Track the sale of credits with a red-line revision to the SDP or final road construction plan. Retention banks may sell 2 acres of credit for every 1 acre of forest conservation obligation. Planted banks may sell 1 acre of credit for every acre of obligation.	A and DPZ

A = Applicant
 DPZ = Department of Planning and Zoning
 DPW = Department of Public Works
 DRP = Department of Recreation and Parks
 SRC = Subdivision Review Committee

Figure 5-I: Variance Requests Process

Subdivision and Site Development Stages	Variance Request Requirements/Actions	Responsible Party
1. Alternative Compliance Application and Plan Exhibit	<ul style="list-style-type: none"> a. Prepare and submit an Alternative Compliance Application, which includes plan exhibit and required justification. b. Review and verify plan and application. c. Conduct site visit to verify the conditions of the site (i.e., forested area and specimen trees). d. Prepare staff report. e. Meet to discuss Application and comments from the SRC. f. Prepare Director's Written Decision. g. Sign Written Decision. h. If Variance Request is approved, but the Applicant disagrees with the conditions of approval, the Applicant may submit a reconsideration request. i. If Variance Request is approved, the project may proceed for scheduling of the Planning Board hearing, if applicable. j. If Variance Request is denied, the Applicant may file a Department Appeal. 	<p>A</p> <p>SRC DPZ and DRP DPZ DPZ, DRP and OCS DPZ DPZ, DRP and OCS A</p> <p>A</p> <p>A</p>

A = Applicant
 DPZ = Department of Planning and Zoning
 DRP = Department of Recreation and Parks
 OCS = Office of Community Sustainability
 SRC = Subdivision Review Committee

APPENDICES



APPENDIX A: GLOSSARY OF TERMS

Afforestation - the establishment of new forest on an area presently without forest cover, by planting in accordance with the practices specified in the Forest Conservation Manual.

Agricultural Activity - the use of land for agricultural purposes, including: dairying, pasturage, growing crops, bee keeping, horticulture, floriculture, orchards, plant nurseries, viticulture, aquaculture, silviculture, and animal and poultry husbandry; the breeding, raising, training and general care of livestock for uses other than food, such as sport or show purposes; construction and maintenance of barns, silos, and other similar structures, the use of farm machinery, the primary processing of agricultural products and the sale of agricultural products produced on the land where the sales are made; and other uses directly related to or as an accessory use of the premises for farming and agricultural purposes.

Break Even Point - the point at which the forest conservation requirements can be met solely through forest retention and no reforestation is required.

Caliper - tree diameter measured above the root collar in accordance with American Nursery and Landscape Association standards.

Champion Trees - the largest tree of its species within the United States, the State or Howard County, as determined by the Maryland Department of Natural Resources.

Commercial Logging and Timber Harvesting - the cutting and removing of tree stems from a site for commercial purposes, leaving the root mass intact.

Critical Habitat for Endangered Species - a habitat occupied by an endangered species as determined or listed under Section 4-2A-04 or Section 10-2A-04, Natural Resources Article, Annotated Code of Maryland.

Critical Habitat Area - a critical habitat for threatened or endangered species and its surrounding protection area. A critical habitat area shall:

1. Be likely to contribute to the long-term survival of the species;
2. Be likely to be occupied by the species for the foreseeable future; and
3. Constitute habitat of the species which is considered critical under Natural Resources Article, Section 4-2A-04 or Section 10-2A-06, Annotated Code of Maryland.

Critical Root Zone - the essential area of the roots that must be maintained or protected for the tree's survival.

Declaration of Intent - a notarized statement signed by a landowner or developer certifying that:

1. Proposed development is exempt from the requirement for an approved Forest Conservation Plan; and
2. No development requiring a Forest Conservation Plan will occur on the site within five years of the date of the completion of the exempt development.

Department - the Howard County Department of Planning and Zoning.

Development - the establishment of a principal use of a site; a change in a principal use of a site; or the improvement or alteration of a site by the construction, enlargement, or relocation of a structure; the provision of stormwater management or roads; the grading of existing topography; the clearing or grubbing of existing vegetation; or any other non agricultural activity that results in a change in existing site conditions.

Diameter at Breast Height or DBH - the outside bark diameter of a tree measured at 4.5 feet above the ground on the uphill side of the tree.

Erodible Soils - Soils with a Universal Soil Loss Equation erodibility index (K) value greater than 0.35.

Exotic Species - an organism that occurs artificially in locations beyond their known historical natural ranges. Species exotic to the United States are those transported from other continents and other parts of the world. Other terms used to describe exotic species include non-native, alien, foreign, introduced and non-indigenous.

Forest - a biological community dominated by trees and other woody plants covering an area of 10,000 square feet or greater, with a minimum width of 35 feet for an existing forest and 50 feet for a planted forest. Forest includes:

1. Areas with a minimum tree cover ratio of 100 trees per acre with at least 50% of these trees being at least 2 inches in diameter at a height of 4.5 feet above ground;
or
2. Areas meeting the criteria above that have been cut but not cleared.

Forest does not include orchards, tree nurseries, Christmas tree farms, silvopasture or other types of tree crops.

Forest Conservation - the retention of existing forest or the creation of new forest at the levels set by this subtitle.

Forest Conservation Agreement - a legally binding agreement, secured by a surety, to ensure the survivability of all sites retained, afforested and reforested.

Forest Conservation Easement - an easement area designated to protect forest conservation retention, afforestation and reforestation sites.

Forest Conservation Fund - a fund into which payments of in-lieu fees or penalties will be made when an applicant cannot comply with or violates the requirements of the Forest Conservation Program. Such funds shall only be used for purposes specified in the program.

Forest Conservation Plan - a plan which shows the impacts of a proposed development on existing forest resources. A Forest Conservation Plan includes existing forest areas to be removed or retained; the location, extent and specifications for any reforestation or afforestation required; and legal measures to protect forest resources after completion of development.

Forest Conservation Program – the administration of the Howard County Forest Conservation Act and Manual by appropriate County agencies, as part of a local Howard County program developed under the authority of the State Forest Conservation Act, consistent with the intent, requirements and standards of the Act, Natural Resources Article, 5-1601 et seq., Annotated Code of Maryland.

Forest Cover - the area of a site meeting the definition of forest.

Forest Product - any wood fiber product extracted from a forest which can be sold on the commercial market.

Forest Stand - a contiguous group of trees meeting the definition of forest sufficiently uniform in species composition, arrangement of age classes, and condition to be a distinguishable, homogeneous unit.

Forest Stand Delineation - the evaluation of existing forests and other vegetation on a site proposed for development.

Green Infrastructure Network – the system of hubs and corridors mapped in the Howard County Green Infrastructure Network Plan published by the Department of Planning and Zoning in December 2012, as amended.

Growing Season - the time, from spring to fall, during which consecutive, frost-free days occur. For Howard County, the growing season is March 1 thru November 30.

Historic Site – any site or structure listed on the Howard County Historic Sites Inventory.

Historic Structure – a structure or cluster of structures situated within Howard County which, together with its appurtenances and environmental setting, have significant historic or architectural value and have been designated as such by resolution of the County Council.

Historic Trees – trees that are part of an historic site or associated with an historic structure.

Hydric Soils - are generally defined as soils that are saturated, flooded or ponded long enough during the growing season to develop anaerobic conditions in the upper layer of soil.

Institutional Uses - land uses that provide community and cultural facilities, including: government structures, facilities and uses, including public schools and colleges; museums and libraries; nonprofit clubs, lodges and community halls; religious activities; and volunteer fire departments.

Invasive Species - an invasive plant species is one that displays rapid growth and spread, allowing it to establish over a large area within a relatively short period of time. Often invasive plants are also exotic plants free from the natural controls of their native lands and these plant species display rapid and unrestricted growth in new environments. Invasiveness is enhanced by features such as strong vegetative growth, abundant seed production, high seed germination rates, long-lived seeds, and rapid maturation to seed producing ages. Invasive species can also include other types of introduced organisms, such as the emerald ash borer and gypsy moth, which are invertebrate pests, and fungal diseases such as the chestnut blight and Dutch elm disease.

Impervious Surface – any permanent artificial surface, including but not limited to areas covered by asphalt, concrete, pavers, permeable paving, rooftops and decks.

Limit of Disturbance - the boundary of permitted changes to existing site conditions due to clearing and grading, as well as other activities associated with site development such as

parking of vehicles and equipment, storage of materials, and disposal of construction debris.

Linear Projects – a project having an elongated configuration with nearly parallel sides designed to transport a utility product or public service (for example, gas, electricity, water, sewer, communications, transportation) not otherwise addressed in an application for subdivision.

Manual - the Howard County Forest Conservation Manual.

Mixed Use Development – A development including residential, nonresidential and open space land uses which has been approved on a Preliminary Development Plan.

Native Plants and Communities - plant species or communities that naturally occur in a given location where requirements for light, warmth, moisture, shelter and nutrients are met.

Natural Regeneration - the natural establishment of native trees and other vegetation. Native trees must exist in sufficient numbers to meet the 350 seedlings per acre standard for forest by the end of the two growing season post-construction period or the 100 trees per acre standard with a minimum height of 3 to 4 feet by the end of the seven growing season post-construction period.

Net Tract Area - the total area measured at a minimum to the nearest 1/10 acre, whether forested or not, of a proposed development, exclusive of any allowed deductions. Net Tract Area is used in calculating any reforestation or afforestation obligations that may be created by the proposed development.

Non-native Species - see Exotic Species.

Noxious Weeds - this term is a legal designation used specifically for plant species that have been determined to be major pests of agriculture and are subject by law to certain restrictions. The US Department of Agriculture and the Maryland Department of Agriculture regulate noxious weeds.

Other Terms - "Other Terms" which are defined in the Natural Resources Article, Section 5-1601, "DEFINITIONS", Annotated Code of Maryland are incorporated by reference and shall apply to this subtitle for any terms which are not defined in this section or the Manual.

Planned Unit Development - a development comprised of a combination of land uses or varying intensities of the same land-use in accordance with an integrated plan that provides flexibility in design with at least 20% of the land permanently dedicated to open space.

Priority Funding Area – an area designated as such under Title 5, Subtitle 7B of the State Finance and Procurement Article. The Howard County Priority Funding Area is designated as all land within the Planned Service Area for public water and sewerage.

Proctor Density – is the density of a soil, measured under optimum soil moisture content as a percentage of maximum dry density. The Proctor Density test is a construction industry standard test for soil compaction.

Public Utility - a transmission line, an electric generating station, or a water, sewer, electric, gas, telephone or cable television service line.

Real Estate Transaction - provides a security, leasehold, or other legal or equitable interest, including a transfer of title, of a portion of a lot or parcel.

Reforestation - the establishment, in accordance with this Manual, of new forest cover to replace forest resources lost because of development activities.

Reforestation Threshold - the quantitative standard used to calculate when reforestation requirements increase from a low ratio of replacement for each acre cleared to a high ratio for each acre cleared. The ratios are increased if the replacement site is not within the same watershed as the development site. The reforestation threshold is also used as a baseline to calculate any forest retention credit that can be used to reduce a reforestation obligation.

Retention - the deliberate holding and protecting of existing trees, shrubs or plants on the site according to standards as set forth in this Manual.

Seedling - an unbranched woody plant, less than 24 inches in height and having a diameter of less than one-half inch measured at two inches above the root collar with roots 8 inches or longer.

Selective Clearing - the careful and planned removal of trees, shrubs, and plants using specific standards and protection measures under an approved Forest Conservation Plan.

Sensitive Species Project Review Area - a digital map layer prepared by the Maryland Department of Natural Resources, which represents the general locations of documented rare, threatened and endangered species.

Silviculture – the science of growing and cultivating forest crops.

Silvopasture – the intentional integrated growing of trees and forage for livestock grazing.

Soil Amendments - the modification of soil properties for improvement of soil structure; not to be confused with fertilizers whose purpose is to correct chemical imbalances in soils for silvicultural purposes.

Specimen Trees – trees having a diameter measured at 4.5 feet above the ground of 30 inches or more, or trees having 75% or more of the diameter of the current State Champion tree of that species. Also includes Champion Trees.

Stand Structure - the composition of the forest stand with reference to forest association, dominant and co-dominant species, understory and herbaceous species.

Stream Restoration Project – an activity that:

1. Is designed to stabilize stream banks or enhance stream function or habitat located within an existing stream, waterway or floodplain;
2. Avoids and minimizes impacts to forests and provides for replanting on-site an equivalent number of trees to the number removed by the project;
3. May be performed under a municipal separate storm sewer system permit, a watershed implementation plan growth offset or another plan administered by the State or Howard County to achieve or maintain water quality standards; and
4. Is not performed to satisfy stormwater management, wetlands mitigation or any other

regulatory requirement associated with proposed development activity.

Tree - a large, branched, woody plant having one or several self-supporting stems or trunks that reach a height of at least 20 feet at maturity.

Understory Trees - trees with crowns entirely below the general level of the canopy receiving little or no sunlight from above or the sides.

Urban Canopy – tree canopy inside the Planned Service Area for public water and sewerage that does not meet the minimum area and width requirements to qualify as forest, but does provide air quality, water quality, and habitat benefits, as determined by the Howard County Department of Planning and Zoning.

Watershed - all lands lying within an area described as a 12-digit sub-basin in the water quality regulations adopted by the Maryland Department of the Environment.

Whip - an unbranched woody plant greater than 24 inches in height and having a diameter of less than one inch measured at two inches above the root collar.

APPENDIX B: DECLARATION OF INTENT FORMS

A Declaration of Intent Form is available for:

- Single residential lot clearing less than 20,000 square feet of forest
- Forestry activities
- Agricultural activities clearing more than 40,000 square feet of forest within one year
- Subdivision for real estate transaction
- Linear project clearing less than 20,000 square feet of forest

Howard County Forest Conservation Program

DECLARATION OF INTENT

Single Residential Lot Clearing Less Than 20,000 Square Feet of Forest

File Number Election District Tax Map Lot or Parcel

Name(s) Location

I (We) the Owner(s) of the real property described above and such lot being a single residential lot, hereby declare and certify my (our) intention to make the site improvements listed herein but not clear more than 20,000 square feet of existing forest resources in accordance with the provisions of Howard County Code, Section 16.1202(b)(2)(i) for a period of five years following this date. [Please note: The limit of disturbance may extend off-site provided that the purpose of the disturbance is to facilitate the development of the single lot or parcel, and that the total area of forest cut, cleared or graded both on and off-site is less than 20,000 square feet.]

I (We) further certify that upon completion of the forest clearing activity, I (we) will provide the Department of Planning and Zoning written confirmation that the forest clearing is completed. In the absence of such confirmation, the date of completion shall be deemed to be one year following the date of the last of the following to occur:

- a) approval of the site development plan;
b) issuance of grading permit;
c) issuance of the building permit.

I (We) further certify that any forest resources to be cleared are not protected by any previously approved Forest Conservation Plan.

Site improvements proposed:

Description and extent of any forest resources to be cleared:

If the present or subsequent Owners make application for an activity regulated under Howard County Code Section 16.1202(a), or if total clearing of forest resources following the date of this declaration exceeds 20,000 square feet, the County may require the Owner to meet the reforestation or afforestation requirements established in Sections 16.1206 and 16.1207 of the Howard County Code and may also assess a penalty fee for forested areas cut in violation of the terms of the exemption.

I (We) further certify that this declaration and all conditions herein shall be expressly referenced in and attached to all deeds and other documents which create or transfer any legal or equitable interest in the aforesaid property, in order to provide notice to the new owner(s) that they assume all obligations to conform to the requirements of Section 16.1200, et seq. should they propose any activity regulated thereunder.

I (We) declare under the penalties of law, that this declaration, including any accompanying forms and statements, has been examined by me (us) and the information contained herein, to the best of my (our) knowledge, information, and belief, is true, correct and complete.

Signature(s) _____ Date _____

STATE OF MARYLAND, HOWARD COUNTY, TO WIT:

I HEREBY CERTIFY that on this _____ day of _____, 20 ____, before me, the subscriber, a Notary Public of the State of Maryland, in and for the County aforesaid, personally appeared

party/parties to the within Declaration of Intent, and he/she/they acknowledged the same to be his / her / their act.

AS WITNESS my Hand and Notarial Seal.

Notary Public

My Commission Expires: _____

Howard County Forest Conservation Program

DECLARATION OF INTENT

Forestry Activities

File Election Tax Lot or
Number District Map Parcel

Name(s)
Location

I (We) _____, the
Owner(s) of the real property described above hereby declare my (our) intention to continue
and/or place into commercial forestry use the above property in accordance with the provisions
of the Howard County Code, Sections 16.1202(b)(2)(ii) and 16.1202(c).

- 3. I (We) certify that the proposed commercial forestry activities are exempt from the
requirements of Section 16.1202(a) of the Howard County Code to file a Forest
Conservation Plan.
4. Upon completion or termination of the commercial forestry activities, I (we) will provide
the Department of Planning and Zoning a certification prepared by a qualified
professional that the activities are ended.
5. I (We) certify that no activity which requires the filing of a Forest Conservation Plan
pursuant to Section 16.1202(a) of the Howard County Code will occur within 5 years
of the date of the completion of the exempt commercial forestry activities.
6. This declaration and adherence to the exemption provisions of Section 16.1202 do not
exempt the proposed activity from any other requirements or conditions for commercial
forestry use.
7. I (We) further certify that this Declaration and all conditions herein shall be expressly
referenced in and attached to all deeds and other documents which create or transfer
any legal or equitable interest in the aforesaid property, in order to provide notice to
the new owner(s) that they assume all obligations to conform to the requirements of
Section 16.1200, et seq. should they propose any activity regulated thereunder.

If the Owner makes application for an activity regulated under Howard County Code, Section
16.1202(a), or constructs non-forestry structures or site improvements on all or part of the parcel
within five (5) full years following the date of certification that the activities have been completed,
the County can require the Owner to meet the reforestation or afforestation requirements

established in Sections 16.1206 and 16.1207 of the Howard County Code and may also assess a penalty fee for forested areas cut in violation of the forestry exemption.

I (We) declare that this declaration, including any accompanying forms and statements, has been examined by me (us) and the information contained herein, to the best of my (our) knowledge, information and belief, is true, correct and complete.

Signature(s)

Date

STATE OF MARYLAND, HOWARD COUNTY, TO WIT:

I HEREBY CERTIFY that on this _____ day of _____, 20 ____, before me, the subscriber, a Notary Public of the State of Maryland, in and for the County aforesaid, personally appeared

party/parties to the within Declaration of Intent, and he/she/they acknowledged the same to be his / her / their act.

AS WITNESS my Hand and Notarial Seal.

Notary Public

My Commission Expires: _____

Howard County Forest Conservation Program

DECLARATION OF INTENT

Agricultural Activities Clearing More Than 40,000 Square Feet of Forest within One Year

File Number _____ Election District _____ Tax Map _____ Lot or Parcel _____

Name(s) _____
Location _____

I (We) _____, the Owner(s) of the real property described above hereby declare my (our) intention to clear forest areas for the purpose of agricultural uses on the above property in accordance with the provisions of the Howard County Code, Sections 16.1202(b)(2)(iii) and 16.1202(c). I (We) certify that such clearing is exempt from the requirement of Section 16.1202(a) of the Howard County Code to file a Forest Conservation Plan.

The exempt agricultural uses and the areas affected are:

Structures built to carry out agricultural uses are: (description and square feet of ground affected)

Total amount of forest areas to be cleared are _____ and are shown on the attached plot plan.

I (We) certify that upon completion of all forest clearing activity, I (we) will provide the Department of Planning and Zoning written confirmation that the forest clearing is completed. Further, I (we) certify that no activity which requires the filing of a Forest Conservation Plan pursuant to Section 16.1202(a) of the Howard County Code will occur within 5 years of the completion of all forest clearing activity.

If the Owner makes application for an activity regulated under Howard County Code, Section 16.1202(a) on all or part of the parcel within five (5) full years following the date of certification that the forest clearing has been completed, the County can require the Owner to meet the reforestation or afforestation requirements established in Sections 16.1206 and 16.1207 of the Howard County Code and may also assess a penalty fee for forested areas cut in violation of the terms of this exemption.

I (We) understand that any subsequent clearing of additional forest resources for agricultural activities beyond the amounts cited above shall require an amendment to this Declaration to show the amount and location of such clearing.

I (We) further certify that this Declaration and all conditions herein shall be expressly referenced in and attached to all deeds and other documents which create or transfer any legal or equitable interest in the aforesaid property, in order to provide notice to the new owner(s) that they assume all obligations to conform to the requirements of Section 16.1200, et seq. should they propose any activity regulated thereunder.

I (We) declare under the penalties of law, that this Declaration, including any accompanying forms and statements, has been examined by me (us) and the information contained herein, to the best of my (our) knowledge, information, and belief, is true, correct and complete.

Signature(s)

Date

STATE OF MARYLAND, HOWARD COUNTY, TO WIT:

I HEREBY CERTIFY that on this _____ day of _____, 20 ____, before me, the subscriber, a Notary Public of the State of Maryland, in and for the County aforesaid, personally appeared

party/parties to the within Declaration of Intent, and he/she/they acknowledged the same to be his / her / their act.

AS WITNESS my Hand and Notarial Seal.

Notary Public

My Commission
Expires:

Howard County Forest Conservation Program

DECLARATION OF INTENT

Subdivision for Real Estate Transaction

File Election Tax Lot or
Number _____ District _____ Map _____ Parcel _____

Name(s) _____
Location _____

We _____ and _____, the Grantor and Grantee of a deed of trust, mortgage or other security interest, or Landlord and Tenant, of the real property described above hereby declare our intention to subdivide the above property for one or more of the purposes set forth in Section 16.1202(b)(2)(iv) of the Howard County Code. We further certify that this transaction does not involve a change in land use, or facilitate new development or redevelopment, with associated land disturbing activities, and is exempt from the requirement of Section 16.1202(a) of the Howard County Code to file a Forest Conservation Plan.

We further certify that no activity which requires the filing of a Forest Conservation Plan pursuant to Section 16.1202(a) of the Howard County Code will occur within 5 years of the execution of this Declaration of Intent.

If the subsequent or present owners of tenants conduct any activity regulated under Howard County Code, Section 16.1202(a) without complying with the requirements of Section 16.1200, et seq. of the Code, the County may require the signatories to this Declaration of Intent, and/or their successors-in-interest, to meet the reforestation or afforestation requirements established in Sections 16.1206 and 16.1207 of the Code and may also assess a penalty fee for forested areas cut in violation of the real estate transaction exemption.

We further certify that this Declaration and all conditions herein shall be expressly referenced in and attached to all deeds and other documents which create or transfer any legal or equitable interest in the aforesaid property, in order to provide notice to the new owner(s) that they assume all obligations to conform to the requirements of Section 16.1200, et seq. should they propose any activity regulated thereunder.

We declare under the penalties of law that this Declaration, including any accompanying forms and statements, has been examined by use and the information contained herein, to the best of our knowledge, information, and belief, is true, correct and complete.

Grantor/Landlord : (circle appropriate designation)

Signature(s)

Date

Grantee/Tenant : (circle appropriate designation)

Signature(s)

Date

STATE OF MARYLAND, HOWARD COUNTY, TO WIT:

I HEREBY CERTIFY that on this _____ day of _____, 20 __, before me, the subscriber, a Notary Public of the State of Maryland, in and for the County aforesaid, personally appeared

party/parties to the within Declaration of Intent, and he/she/they acknowledged the same to be his / her / their act.

AS WITNESS my Hand and Notarial Seal.

Notary Public

My Commission
Expires:

Howard County Forest Conservation Program

DECLARATION OF INTENT

Linear Project Clearing Less Than 20,000 Square Feet of Forest

File Number Election District Tax Map Lot or Parcel

Name(s) Location

I (We) the Owner(s) of the real property described above, hereby declare and certify my (our) intention to make the site improvements listed herein for a linear project, but not clear more than 20,000 square feet of existing forest resources in accordance with the provisions of Howard County Code, Section 16.1202(b)(2)(v) for a period of five years following this date.

I (We) further certify that upon completion of the forest clearing activity, I (we) will provide the Department of Planning and Zoning written confirmation that the forest clearing is completed. In the absence of such confirmation, the date of completion shall be deemed to be one year following the date of the last of the following to occur:

- a) approval of the site development plan;
b) issuance of grading permit;
c) issuance of the building permit.

I (We) further certify that any forest resources to be cleared are not protected by any previously approved Forest Conservation Plan.

Site improvements proposed:

Description and extent of any forest resources to be cleared:

If the present or subsequent Owners make application for an activity regulated under Howard County Code Section 16.1202(a), or if total clearing of forest resources following the date of this declaration exceeds 20,000 square feet, the County may require the Owner to meet the reforestation or afforestation requirements established in Sections 16.1206 and 16.1207 of the Howard County Code and may also assess a penalty fee for forested areas cut in violation of the terms of the exemption.

I (We) further certify that this declaration and all conditions herein shall be expressly referenced in and attached to all deeds and other documents which create or transfer any legal or equitable interest in the aforesaid property, in order to provide notice to the new owner(s) that they assume all obligations to conform to the requirements of Section 16.1200, et seq. should they propose any activity regulated thereunder.

I (We) declare under the penalties of law, that this declaration, including any accompanying forms and statements, has been examined by me (us) and the information contained herein, to the best of my (our) knowledge, information, and belief, is true, correct and complete.

Signature(s) _____ Date _____

STATE OF MARYLAND, HOWARD COUNTY, TO WIT:

I HEREBY CERTIFY that on this _____ day of _____, 20 __, before me, the subscriber, a Notary Public of the State of Maryland, in and for the County aforesaid, personally appeared

party/parties to the within Declaration of Intent, and he/she/they acknowledged the same to be his / her / their act.

AS WITNESS my Hand and Notarial Seal.

Notary Public

My Commission Expires: _____

APPENDIX C: FORMS AND WORKSHEETS

This appendix contains the following forms and worksheets:

- C-1: Forest Stand Analysis Table
- C-2: Forest Conservation Worksheet
- C-3: Forest Conservation Worksheet Explanation

C-1: Forest Stand Analysis Table

Applicant: _____ Project Name: _____ Submission No: _____

Key	Community Type	Community Area	Soil Type	Typical Tree Cover for Soil Type	Dominant Species	% Cover	DBH	Stand Successional Stage	Stand Condition	Community Area in Sensitive Environments

C-2: Forest Conservation Worksheet

FOREST CONSERVATION WORKSHEET FOR _____

Net Tract Area

A.	Total (Gross) Tract Area	A =	0.00
B.	Area within 100-year Floodplain	B =	0.00
C.	Other Deductions (Identify: _____)	C =	0.00
D.	Net Tract Area	D =	0.00

Land Use Category

Insert the number "1" under the appropriate land use (limit to only one entry)

Resid. Rural LD	Resid. Rural MD	Resid. Suburban	Inst./ Linear	Retail/Ind./ Office	Mixed Use/ PUD
0	0	0	0	0	0

E.	Afforestation Threshold	(Net Tract Area x	0%)	E =	0.00
F.	Reforestation Threshold	(Net Tract Area x	0%)	F =	0.00

Existing Forest Cover

G.	Existing Forest Cover within the Net Tract Area	G =	0.00
H.	Area of Forest above Afforestation Threshold	H =	0.00
I.	Area of Forest above Reforestation Threshold	I =	0.00

Break Even Point

J.	Break Even Point	J =	0.00
K.	Forest Clearing Permitted without Mitigation	K =	0.00

Proposed Forest Clearing

L.	Total Area of Forest to be Cleared	L =	0.00
M.	Total Area of Forest to be Retained	M =	0.00

Planting Requirements Inside Watershed

N.	Reforestation for Clearing above the Reforestation Threshold	N =	0.00
P.	Reforestation for Clearing below the Reforestation Threshold	P =	0.00
Q.	Credit for Retention above the Reforestation Threshold	Q =	0.00
R.	Total Reforestation Required	R =	0.00
S.	Total Afforestation Required	S =	0.00
T.	Total Reforestation and Afforestation Requirement	T =	0.00
U.	75% of Total Obligation (Retention + Planting)	U =	0.00
V.	Planting Required Onsite to meet 75% Obligation	V =	0.00

Planting Requirements Outside Watershed

W.	Total Planting within Development Site Watershed	W =	0.00
X.	Total Afforestation Required	X =	0.00
Y.	Remaining Planting within Watershed for Reforestation Credit	Y =	0.00
Z.	Reforestation for Clearing above the Reforestation Threshold	Z =	0.00
AA.	Reforestation for Clearing below the Reforestation Threshold	AA =	0.00
BB.	Credit for Retention above the Reforestation Threshold	BB =	0.00
CC.	Total Reforestation Required	CC =	0.00
DD.	Total Afforestation and Reforestation Requirement	DD =	0.00

Date: _____

C-3: Forest Conservation Worksheet Explanation

This appendix explains the methodology behind the Forest Conservation Worksheet and provides directions for filling out the worksheet. An Excel spreadsheet file that calculates forest conservation obligations is available on the Department of Planning and Zoning web page. The DPZ worksheet must be used for all submissions.

Net Tract Area

- | | | |
|---------------------------------------|-----|--|
| A. Total (Gross) Tract Area | A = | <input style="width: 90%;" type="text"/> |
| B. Area within 100-year Floodplain | B = | <input style="width: 90%;" type="text"/> |
| C. Other Deductions (Identify: _____) | C = | <input style="width: 90%;" type="text"/> |
| D. Net Tract Area | D = | <input style="width: 90%;" type="text"/> |

Fill in the acreage of A, B and C to the nearest 0.1 acre (at a minimum) based on project site data. Item C may include deductions such as previously developed areas covered by an impervious surface or the area of a preservation parcel being created by a rural cluster subdivision. The spreadsheet will calculate the net tract area (D), by deducting the floodplain and other allowed deductions (B and C) from the gross site area (A).

Land Use Category

- | | | | | | |
|--|--|--|--|--|--|
| Resid.
Rural LD | Resid.
Rural MD | Resid.
Suburban | Inst./
Linear | Retail/Ind./
Office | Mixed Use/
PUD |
| <input style="width: 90%;" type="text"/> | <input style="width: 90%;" type="text"/> | <input style="width: 90%;" type="text"/> | <input style="width: 90%;" type="text"/> | <input style="width: 90%;" type="text"/> | <input style="width: 90%;" type="text"/> |
- | | | | |
|----------------------------|----------------------------|-----|--|
| E. Afforestation Threshold | (Net Tract Area x _____ %) | E = | <input style="width: 90%;" type="text"/> |
| F. Reforestation Threshold | (Net Tract Area x _____ %) | F = | <input style="width: 90%;" type="text"/> |

Select the land use category for the project and enter the number 1 under the appropriate land use. The land use categories are described in Figure 3-B of the Howard County Forest Conservation Manual, 2021. The spreadsheet will calculate the afforestation and reforestation thresholds percentage and acreage (E and F) based on the land use category selected.

Existing Forest Cover

- | | | |
|--|-----|--|
| G. Existing Forest Cover within the Net Tract Area | G = | <input style="width: 90%;" type="text"/> |
| H. Area of Forest above Afforestation Threshold | H = | <input style="width: 90%;" type="text"/> |
| I. Area of Forest above Reforestation Threshold | I = | <input style="width: 90%;" type="text"/> |

Fill in item G based on project site data. The spreadsheet will calculate the area of existing forest above the afforestation and reforestation thresholds (H and I).

If existing forest cover is less than the afforestation threshold (if G is less than E), afforestation will be required (see S, below). If clearing of existing forests below the afforestation threshold is proposed, reforestation requirements will apply in addition to afforestation requirements (see T, below).

If existing forest cover equals or exceeds the afforestation minimum (if G is equal to or greater

than E) and clearing of existing forests is proposed, reforestation requirements may apply (see R, below).

Break Even Point

- J. Break Even Point J = _____
- K. Forest Clearing Permitted without Mitigation K = _____

The spreadsheet will calculate the break even point (J), which is the amount of forest that must be retained (one-third of the forest above the reforestation threshold) to balance the reforestation obligation for any clearing. The spreadsheet will calculate the amount of forest that can be cleared without incurring a mitigation obligation (K) as the existing forest minus the break even point (G minus J).

Proposed Forest Clearing

- L. Total Area of Forest to be Cleared L =
- M. Total Area of Forest to be Retained M = _____

Fill in item L based on project site data. Forest that will be retained but not placed in a Forest Conservation Easement must be recorded as cleared. The spreadsheet will calculate the forest to be retained (M) by deducting the forest to be cleared from the existing forest area (G minus L).

Planting Requirements

- N. Reforestation for Clearing above the Reforestation Threshold N = _____
- P. Reforestation for Clearing below the Reforestation Threshold P = _____
- Q. Credit for Retention above the Reforestation Threshold Q = _____
- R. Total Reforestation Required R = _____
- S. Total Afforestation Required S = _____
- T. Total Reforestation and Afforestation Requirement T = _____
- U. 75% of Total Obligation (Retention + Planting) U = _____
- V. Planting Required Onsite to meet 75% Obligation V = _____

The spreadsheet will calculate any obligations incurred for clearing above the reforestation threshold (N is calculated at 1/2 acre for every acre cleared) or below the reforestation threshold (P is calculated at 2 acres for every acre cleared) and will calculate any credits granted for retaining forests above the reforestation threshold (Q is calculated at 1 acre credit for every acre retained above the reforestation threshold).

Reforestation required (R): If the clearing is less than or equal to the amount of forest clearing permitted without mitigation (if L is less than or equal to K), no reforestation will be required (R will equal 0). The formula for this calculation can also be expressed as: IF N is less than or equal to Q, then R = 0. If the credit for retention above the reforestation threshold (Q) is equal to or greater than the reforestation obligation for clearing above the reforestation threshold (N), then no reforestation is required.

Afforestation required (S): If existing forest cover is less than the afforestation threshold (if G is less than E), afforestation will be required at a rate of 1 acre of planting for every unforested acre below the afforestation threshold. Afforestation must make the total forest equal to the

minimum required (S plus G must equal E).

Reforestation and afforestation required (T): If existing forest cover is below the afforestation threshold and additional clearing of forests is proposed, the reforestation obligation for that clearing is 2 acres for every acre cleared (R). This obligation is in addition to the afforestation obligation of 1 acre for every unforested acre below the afforestation threshold (S). The minimum requirement must be met and compensation for any clearing is required. The total planting required is the sum of reforestation and afforestation required (T equals R plus S).

75% of Total Obligation (Retention + Planting) (U): The spreadsheet calculates 75% of the total obligation (retention plus reforestation and afforestation) that must be met onsite for those residential projects subject to Section 16.1209(b)(2) as U equals 75% of (M plus T).

Planting Required Onsite to meet 75% Obligation (V): The minimum planting that must be done onsite to meet the requirements of Section 16.1209(b)(2) is 75% of the total obligation minus the onsite retention (V equals U minus M). Note that changing onsite retention may also change this minimum planting requirement.

The remaining portion of the worksheet must be completed only if a portion of the forest conservation obligation will be met outside the watershed or through the use of fee-in-lieu.

Planting Requirements Outside Watershed

W. Total Planting within Development Site Watershed	W =	<input type="text"/>
X. Total Afforestation Required	X =	<input type="text"/>
Y. Remaining Planting within Watershed for Reforestation Credit	Y =	<input type="text"/>
Z. Reforestation for Clearing above the Reforestation Threshold	Z =	<input type="text"/>
AA. Reforestation for Clearing below the Reforestation Threshold	AA =	<input type="text"/>
BB. Credit for Retention above the Reforestation Threshold	BB =	<input type="text"/>
CC. Total Reforestation Required	CC =	<input type="text"/>
DD. Total Reforestation and Afforestation Requirement	DD =	<input type="text"/>

Fill in item W based on project site data. Planting within the watershed will first be credited toward any required afforestation and then toward any required reforestation.

Total Afforestation Required (X): If total planting within the development site watershed is sufficient to meet the afforestation obligation (W is greater than or equal to S), then no additional afforestation planting is required outside the watershed (X equals zero). The remaining planting within the watershed for reforestation credit will equal the total planting within the development site watershed minus the required afforestation (Y equals W minus S).

If additional afforestation is required outside the watershed (W is less than S), the additional planting needed will equal the required afforestation minus the total planting within the development site watershed (X equals S minus W). In this case there is no remaining planting acreage within the development site watershed that may be credited toward reforestation (Y equals zero).

Reforestation for Clearing above the Reforestation Threshold (Z): If the remaining planting within the watershed for reforestation credit is sufficient to meet the reforestation for clearing

above the reforestation threshold (Y is greater than or equal to N), no additional planting is needed (Z equals zero). If additional planting must be done outside the watershed to meet the obligation for clearing above the reforestation threshold (Y is less than N), the spreadsheet will calculate the remaining obligation (subtract Y from N), undo the inside the watershed mitigation ratio of ½ acre for every acre cleared, and apply the outside the watershed mitigation ratio of one acre for every acre cleared to this remaining obligation (Z equals ((N minus Y) divided by ½ and multiplied by 1)).

Reforestation for Clearing below the Reforestation Threshold (AA): If the remaining planting within the watershed is sufficient to meet the reforestation for clearing above and below the reforestation threshold (Y minus N minus P is greater than or equal to zero), no additional planting is needed (AA equals zero). If additional planting is needed, the remaining obligation is calculated in one of two ways. If the remaining planting within the watershed for reforestation credit is less than or equal to the reforestation for clearing above the threshold (Y is less than or equal to N), then the remaining obligation is the full reforestation for clearing below the threshold (P). If the remaining planting within the watershed for reforestation credit is greater than the reforestation for clearing above the threshold (Y is greater than N), then the remaining obligation is P minus (Y minus N). The spreadsheet will undo the inside the watershed mitigation ratio of 2 acres for every acre cleared and apply the outside the watershed mitigation ratio of 3 acres for every acre cleared to this remaining obligation (AA equals remaining obligation divided by 2 and multiplied by 3).

Credit for Retention above the Reforestation Threshold (BB): The credit for retention above the reforestation threshold is the same as the credit for retention above the reforestation threshold within the watershed (BB equals Q).

Total Reforestation Required (CC): The total reforestation is the sum of reforestation for clearing above and below the reforestation threshold, minus the credit for retention above the reforestation threshold (CC equals Z plus AA minus BB).

Total Afforestation and Reforestation Requirement (DD): The total planting required outside the watershed is the sum of afforestation and reforestation required (DD equals X plus CC).

APPENDIX D: PLANT LISTS

The following plant listings are included in this appendix:

- D-1: Forest Associations List
- D-2: Forest Associations Map
- D-3: Native Plant List
- D-4 Invasive Exotic Plant List

D-1: Forest Associations List

Forest associations of Howard County are based on: The natural forests of Maryland: an explanation of the vegetation map of Maryland (with 1:250,000 map) by G. S. Brush, C. Lenk and J. Smith, 1980, Ecological Monographs 50:77-92. The map identifies five forest associations in the County:

- **Tulip Poplar Association**, located in upland areas throughout the eastern three-quarters of the County.
- **Chestnut - Oak Association**, located in upland areas of the western one-quarter of the County and along a small band in the vicinity of the County's Planned Service Area.
- **Chestnut Oak - Post Oak - Blackjack Oak Association**, located in the northeastern corner of the County.
- **Sycamore - Green Ash - Box Elder - Silver Maple Association**, located along major stream valleys in the Piedmont province, primarily west of I-95.
- **River Birch - Sycamore Association**, located along major stream valleys in the Coastal Plain province, primarily east of I-95.

The forest associations are distinguished by the presence of common or characteristic species. Additional species found in these associations are arranged below in order of descending frequency. Note that some associations include Japanese honeysuckle, a species that has naturalized, but is invasive and should not be planted. Care should also be taken if planting brambles, to ensure no invasive species are planted.

Tulip Poplar Association

Red Maple	Pignut Hickory
Flowering Dogwood	Black Oak
Virginia Creeper	Poison Ivy
Black Gum	Greenbriers
White Oak	Beech
Sassafras	Spicebush
Black Cherry	Northern Red Oak
Grape	Mapleleaf Viburnum
Mockernut Hickory	Early Low Blueberry
Southern Arrowwood	Choke Cherry
Japanese Honeysuckle	Brambles

Chestnut - Oak Association

Red Maple	American Chestnut (no longer viable)
White Oak	Mockernut Hickory
Sassafras	Virginia Creeper
Northern Red Oak	Grape
Black Cherry	Tall Deerberry
Black Gum	Brambles
Black Oak	Mapleleaf Viburnum
Early Low Blueberry	Greenbriers
Pignut Hickory	Scarlet Oak
Flowering Dogwood	White Ash

Witch Hazel

Chestnut Oak - Post Oak - Blackjack Oak Association

Red Maple	Sweet Gum
Black Gum	Scarlet Oak
White Oak	Spanish Oak
Sassafras	Mockernut Hickory
Greenbriers	Virginia Creeper
American Holly	Black Cherry
Virginia Pine	Sweet Pignut Hickory
Black Oak	Dwarf Huckleberry
Japanese Honeysuckle	Mountain Laurel
Beech	Southern Arrowwood
Early Low Blueberry	Tall Deerberry
Flowering Dogwood	

Sycamore - Green Ash - Box Elder - Silver Maple Association

Red Maple	Sassafras
Virginia Creeper	White Ash
White Oak	Mockernut Hickory
Flowering Dogwood	Poison Ivy
Grape	Southern Arrowwood
Black Cherry	Black Oak
Northern Red Oak	Pignut Hickory
Spicebush	Brambles
Tulip Poplar	Greenbriers
Black Gum	Ironwood
Japanese Honeysuckle	

River Birch - Sycamore Association

Red Maple	Ironwood
Poison Ivy	American Holly
Virginia Creeper	Flowering Dogwood
Greenbriers	Black Cherry
Sweet Gum	Green Ash
Japanese Honeysuckle	White Oak
Southern Arrowwood	Brambles
Tulip Poplar	Elderberry
Spicebush	Slippery Elm
Black Gum	Sassafras
Grape	

D-2: Forest Associations Map

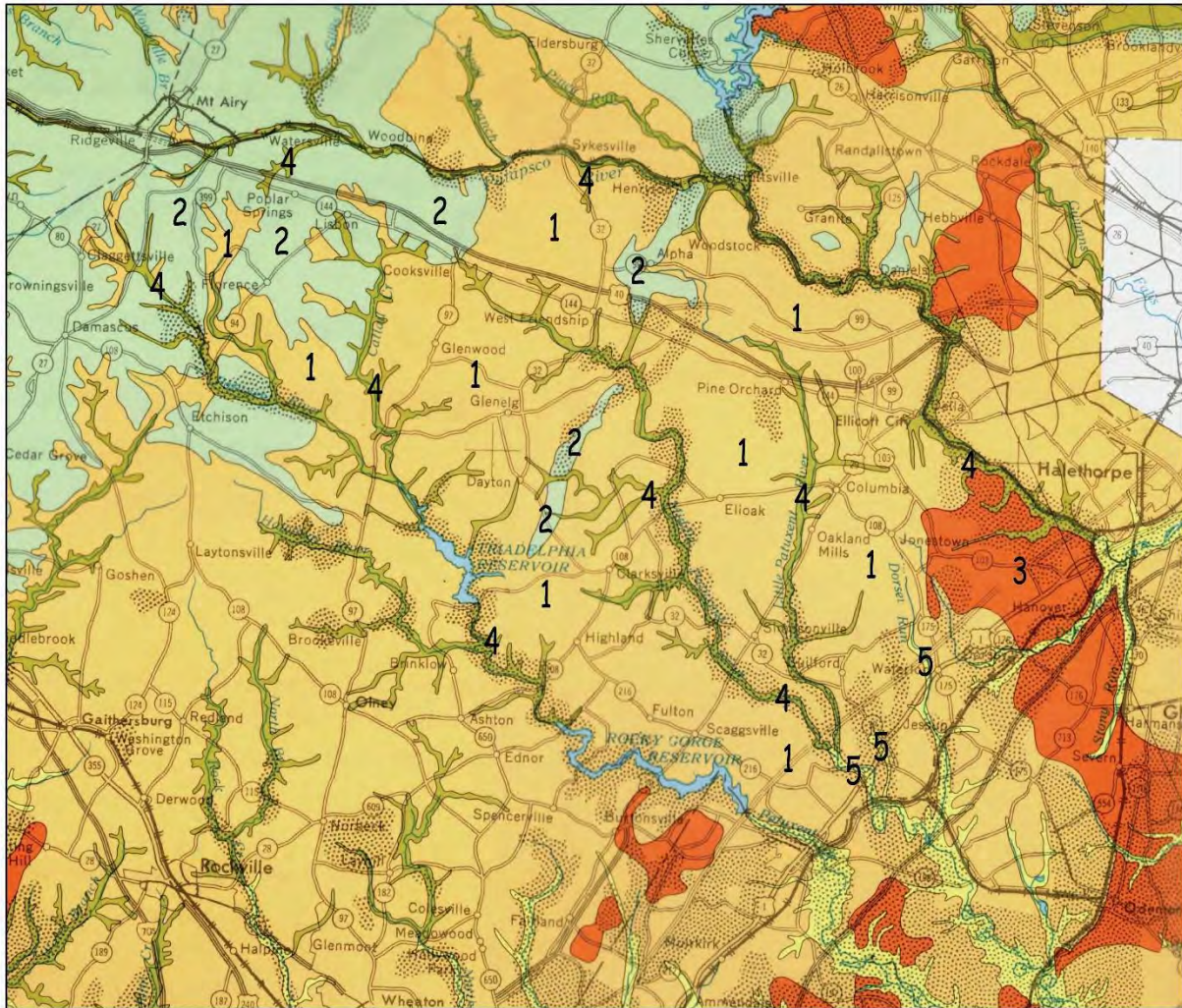

LEGEND

- | | |
|---|---|
| 1 | Tulip Poplar Association |
| 2 | Chestnut Oak Association |
| 3 | Chestnut Oak - Post Oak - Blackjack Oak Association |
| 4 | Sycamore - Green Ash - Box Elder - Silver Maple Association |
| 5 | River Birch - Sycamore Association |

D-3: Native Plant List

SPECIES	COMMON NAME	TYPE	MOISTURE	SUNLIGHT
<i>Acer negundo</i>	Boxelder	small tree	M	S
<i>Acer rubrum</i>	Red Maple	large tree	W/M	S/PS
<i>Acer saccharinum</i>	Silver Maple	large tree	W/M	S/PS
<i>Amelanchier arborea</i> <i>var. arborea</i>	Common Serviceberry	small tree	W/M	S/PS/SH
<i>Amelanchier canadensis</i>	Canadian Serviceberry, Shadbush	small tree	W/M	PS/SH
<i>Betula nigra</i>	River Birch	large tree	W/M	S/PS
<i>Carpinus caroliniana</i>	American Hornbeam	small tree	M	PS/SH
<i>Celtis occidentalis</i>	Hackberry	large tree	W/M	S/PS
<i>Cercis canadensis</i>	Redbud	small tree	M/D	PS/SH
<i>Chionanthus virginicus</i> ¹	White Fringetree	small tree	M/D	S/PS/SH
<i>Cornus alternifolia</i>	Pagoda Dogwood	small tree	M/D	PS/SH
<i>Cornus florida</i>	Flowering Dogwood	small tree	M/D	PS/SH
<i>Diospyros virginiana</i>	Common Persimmon	small tree	M/D	S/PS
<i>Fagus grandifolia</i>	American Beech	large tree	M	S/PS
<i>Fraxinus americana</i> ¹	White Ash	large tree	M	S/PS
<i>Fraxinus pennsylvanica</i> ¹	Green Ash	large tree	M/W	S/PS
<i>Ilex opaca</i>	American Holly	large tree	M	S/PS
<i>Juglans nigra</i>	Black Walnut	large tree	M	PS
<i>Juniperus virginiana</i>	Eastern Red Cedar	large tree	M/D	S/PS
<i>Liquidambar styraciflua</i>	Sweet Gum	large tree	W/M	S/PS
<i>Liriodendron tulipifera</i>	Yellow Poplar	large tree	M	S/PS
<i>Magnolia virginiana</i>	Sweet Bay Magnolia	large tree	W/M	S/PS/SH
<i>Nyssa sylvatica</i>	Black Gum	large tree	W/M/D	S/PS
<i>Oxydendron arboreum</i>	Sourwood	small tree	M	PS
<i>Pinus strobus</i>	White Pine	large tree	M/D	S
<i>Pinus virginiana</i>	Virginia Pine	large tree	M/D	S
<i>Platanus occidentalis</i>	Sycamore	large tree	W/M	S/PS
<i>Prunus serotina</i>	Black Cherry	large tree	M	S
<i>Quercus alba</i>	White Oak	large tree	M	S
<i>Quercus bicolor</i>	Swamp White Oak	large tree	W	S/PS
<i>Quercus coccinea</i>	Scarlet Oak	large tree	M	S
<i>Quercus falcata</i> v. <i>pagodafolia</i>	Cherrybark Oak	large tree	M	S
<i>Quercus palustris</i>	Pin Oak	large tree	M	S
<i>Quercus phellos</i>	Willow Oak	large tree	W/M	S
<i>Quercus prinus</i>	Chestnut Oak	large tree	D	S/PS
<i>Quercus rubra</i>	Northern Red Oak	large tree	M/D	S/PS

SPECIES	COMMON NAME	TYPE	MOISTURE	SUNLIGHT
<i>Quercus veluntina</i>	Black Oak	large tree	M/D	S
<i>Robinia pseudoacacia</i>	Black Locust	large tree	M/D	S
<i>Salix nigra</i>	Black Willow	large tree	W/M	S/PS
<i>Sassafras albidium</i>	Sassafras	small tree	M	S/PS
<i>Taxodium distichum</i>	Bald Cypress	large tree	W	S/PS
<i>Tilia americana</i>	American Basswood or American Linden	large tree	M	S/PS
<i>Tsuga canadensis</i>	Eastern Hemlock	large tree	M	S/PS
<i>Ulmus Americana</i> ²	American Elm	large tree	M	S
<i>Viburnum prunifolium</i>	Blackhaw Viburnum	small tree	W/M	S/PS

¹Avoid planting trees within the Ash family that are susceptible to the Emerald Ash Borer, including Fringetree, White Ash and Green Ash.

²Choose only varieties resistant to Dutch Elm Disease, such as New Harmony or Valley Forge.

Type

Large tree - woody plant usually with one main stem capable of attaining 60 feet in height.

Small tree - woody plant usually with one main stem usually attaining less than 60 feet in height.

Moisture

D = Dry: areas in full sun or in a windy location; water does not remain after a rain.

M = Moist: areas where the soil is damp and occasionally saturated.

W = Wet: areas where the soil is saturated for much of the growing season; many of the plants designated for wet areas tolerate specific ranges of water depth; consult a wetland plant nursery or reference book.

Sunlight

S = Full Sun: the site is in direct sunlight for at least six hours a day during the growing season.

PS = Partial Shade: the site receives approximately three to six hours of direct sunlight a day during the growing season.

SH = Shade: the site receives less than three hours of direct sunlight a day during the growing season.

D-4: Invasive Exotic Plant List

The following is a list of noxious weeds in Maryland. Control of noxious weeds is required by State regulation. Additional information may be obtained through the Maryland Department of Agriculture at <https://mda.maryland.gov/Pages/default.aspx> .

Common Name	Botanical Name
Plumeless Thistle	<i>Carduus acanthoides</i>
Musk Thistle	<i>Carduus nutans</i>
Canada Thistle	<i>Cirsium arvense</i>
Bull Thistle	<i>Cirsium vulgare</i>
Shattercane	<i>Sorghum bicolor</i>
Johnsongrass	<i>Sorghum halepense</i>

The following is a list of exotic or invasive plants that threaten or degrade forests in Maryland.

Common Name	Botanical Name
-------------	----------------

Herbaceous

Garlic Mustard	<i>Alliaria petiolata (A. officinalis)</i>
Small carpetgrass	<i>Arthraxon hispidus</i>
Spotted Knapweed	<i>Centaurea biebersteinii</i>
Crown-vetch	<i>Coronaria varia</i>
Tall Fescue, K31 Fescue	<i>Festuca elatior (F. arundinacea)</i>
Common Daylily	<i>Hemerocallis fulva</i>
Chinese Lespedeza, Sericea Lespedeza	<i>Lespedeza cuneata</i>
Japanese Stiltgrass	<i>Microstegium vimineum (Eulalia viminea)</i>
Chinese Silver Grass	<i>Miscanthus sinensis</i>
Wavyleaf Basketgrass	<i>Oplismenus hirtellus ssp undulatifolius</i>
Common Reed	<i>Phragmites australis (P. communis)</i>
Japanese Knotweed	<i>Polygonum cuspidatum, Fallopia japonica</i>
Lesser Celandine	<i>Ranunculus ficaria</i>

Vines

Fiveleaf Akebia	<i>Akebia quinata</i>
Porcelain Berry	<i>Ampelopsis brevipedunculata</i>
Oriental Bittersweet	<i>Celastrus orbiculatus</i>
Cinnamon Vine	<i>Dioscorea batatas</i>
Climbing Euonymus, Wintercreeper	<i>Euonymus fortunei</i>
English Ivy	<i>Hedera helix</i>
Japanese Honeysuckle	<i>Lonicera japonica</i>
Mile-a-minute Vine, Devil's Tearthumb	<i>Polygonum perfoliatum</i>
Kudzu	<i>Pueraria lobata</i>
Periwinkle	<i>Vinca minor</i>
Wisteria	<i>Wisteria floribunda, W. sinensis</i>

Common Name	Botanical Name
-------------	----------------

Shrubs

Japanese Barberry	<i>Berberis thunbergii</i>
Butterfly Bush	<i>Buddleja spp.</i>
Russian Olive	<i>Elaeagnus angustifolium</i>
Autumn Olive	<i>Elaeagnus umbellate</i>
Winged Burning Bush, Winged Wahoo	<i>Euonymus alatus</i>
Privet	<i>Ligustrum spp.</i>
Bush Honeysuckles, including	<i>Lonicera spp.</i>
Bell's Honeysuckle	<i>Lonicera x bella</i>
Amur Honeysuckle	<i>Lonicera maackii</i>
Morrow's Honeysuckle	<i>Lonicera morrowii</i>
Tartarian Honeysuckle	<i>Lonicera tatarica</i>
Bamboo – running varieties	<i>Phyllostachys spp., Psuedosasa japonica</i>
Common Buckthorn	<i>Rhamnus cathartica</i>
European Buckthorn	<i>Rhamnus frangula</i>
Mutliflora Rose	<i>Rosa multiflora</i>
Strawberry-raspberry, Balloonberry	<i>Rubus illecebrosus</i>
Wineberry	<i>Rubus phoenicolasius</i>
Japanese Spiraea	<i>Spiraea japonica</i>
Coralberry	<i>Symphoricarpos orbiculatus</i>

Trees

Norway Maple	<i>Acer platanoides</i>
Tree of Heaven	<i>Ailanthus altissima</i>
Silk Tree, Mimosa Tree	<i>Albizia julibrissin</i>
Paper Mulberry	<i>Broussonetia papyrifera</i>
White Mulberry	<i>Morus alba</i>
Empress Tree, Princess Tree	<i>Paulownia tomentosa</i>
Sweet Cherry, Bird Cherry	<i>Prunus avium</i>
Bradford Pear	<i>Pyrus calleryana 'Bradford'</i>
Sawtooth Oak	<i>Quercus acutissima</i>

Appendix E: Sample Details and Specifications

This appendix contains sample construction details and guidelines for installation of forest protection devices, best management practices to ensure healthy trees and forests, and planting techniques. This information is based on forestry and horticultural standards current at the time of Manual adoption. Qualified professionals preparing Forest Conservation Plans are advised to incorporate advancements in the forestry and horticultural industries that occur over time to improve practices in the field.

**Figure E-1:
Construction Signs**

**Forest
Retention
Area**

Machinery, Dumping
or Storage of
any materials

Prohibited

Violators are subject to
fines imposed by the
Howard County
Forest Conservation Act



**Reforestation
Project**

Machinery, dumping or storage
of any materials or cutting or
disturbance of vegetation

Prohibited

Violators are subject to fines
imposed by the Howard County
Forest Conservation Act

**Forest
Conservation
Area**

Machinery, Dumping
or Storage of
any materials

Prohibited

Violators are subject to
fines imposed by the
Howard County
Forest Conservation Act

**Specimen
Tree**

Do Not Remove

Machinery, Dumping
or Storage of
any materials

Prohibited

Violators are subject to
fines imposed by the
Howard County
Forest Conservation Act

Notes:

1. Signs to be a minimum of 11" wide by 15" high.
2. Place signs on metal or wood posts 5' above finished grade.
3. Place forest retention, reforestation and or/forest conservation signs 50 to 100' on center and at change of direction around the perimeter of the forest conservation area.
4. Place two specimen tree protection signs at the limit of disturbance (LOD) for each specimen tree to be retained.
5. Do not attach signs to trees.

Source: Howard County Department of Planning and Zoning

**Figure E-2:
 Forest Conservation Easement Signs**

**FOREST
 CONSERVATION
 AREA**

**TREES FOR YOUR
 FUTURE**

DUMPING,
 MACHINERY,
 OR STORAGE OF
 MATERIALS,
 CUTTING OR
 DISTURBANCE
 OF VEGETATION OR
 SOIL IN THIS AREA
**IS STRICTLY
 PROHIBITED**

Howard County Code,
 Title 16 Subtitle 12

VIOLATORS ARE
 SUBJECT TO FINES AS
 IMPOSED BY THE
 HOWARD COUNTY
 FOREST
 CONSERVATION ACT

For more information or to
 report violations, please call
 Howard County
 Department of Recreation
 and Parks, Natural
 Resources Division

410-313-4725
 TTY 410-313-4665



Forest Conservation Decal

Notes:

1. Decal is available from the Department of Recreation and Parks 410-313-1678.
2. Decal material is number 3690 Scotchcal non-reflexive substrate.
3. Dimensions are 2.5" wide by 12" high.
4. Colors are dark green text and border on beige background.

Forest Conservation Post

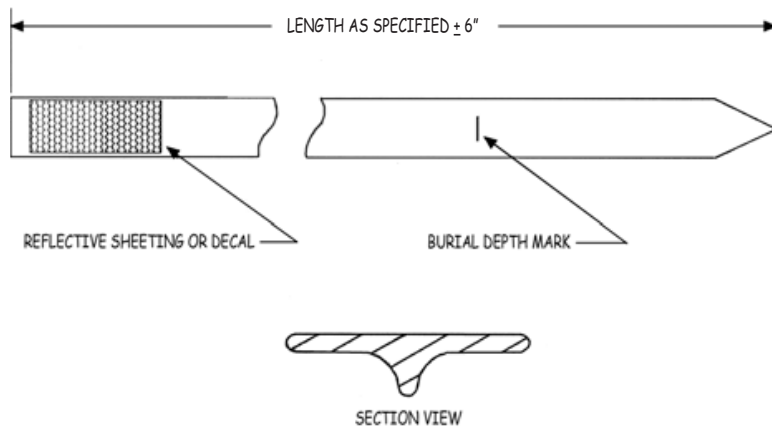

Notes:

1. Post is available from the Department of Recreation and Parks 410-313-1678.
2. Post material is Curflex CRM 250R, UV resistant continuous glass reinforced composite marker.
3. Dimensions are 2.62" wide by 6' high.
4. Post will be embedded in ground to a depth of 18".
5. Color to be dark brown.

Source: Howard County Department of Recreation and Parks

**Figure E-2:
Forest Conservation Easement Signs (continued)**

**FOREST
CONSERVATION
AREA**

Dumping, Machinery, or Storage of Materials,
Cutting or Disturbance of Vegetation or Soil
in this Area
IS STRICTLY PROHIBITED

Violators are subject to fines as imposed by the
Howard County Forest Conservation Act

For more information or to report violations, please call
Howard County Department of Recreation and Parks
410-313-4725
TTY 410-313-4665

Notes:

1. Signs to be a minimum of 11" wide by 15" high.
2. Place signs on metal or wood posts 5' above finished grade.
3. Place forest conservation area signs at 50' to 100' on center and at change of direction around the perimeter of the forest conservation easement.
4. Do not attach signs to trees.

**Figure E-3:
Plastic Mesh Tree Protection Fence**

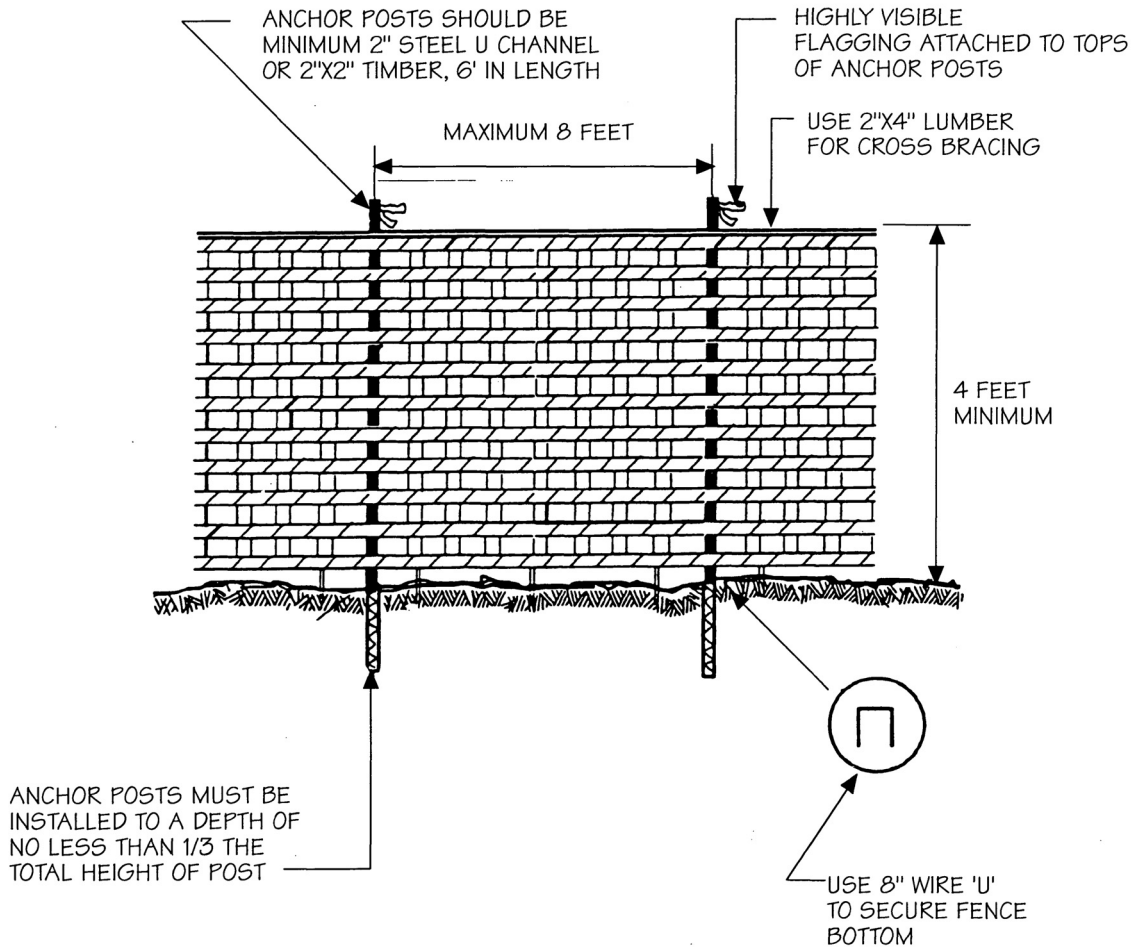

Notes:

1. Blaze orange or blue plastic mesh fence for forest protection device, only.
2. Boundaries of Retention Area will be established as part of the Forest Conservation Plan review process.
3. Stake and flag boundaries of Retention Area prior to installing device.
4. Avoid damage to critical root zone. Do not damage or sever large roots when installing posts.
5. Protection signs are required, see [Figures E-1](#) and [E-2](#).
6. Maintain device throughout construction.

Source: Adapted from Prince George's County, Maryland: Woodland Conservation Manual and State Forest Conservation Technical Manual, 1991

**Figure E-4:
Wire Tree Protection Fence**

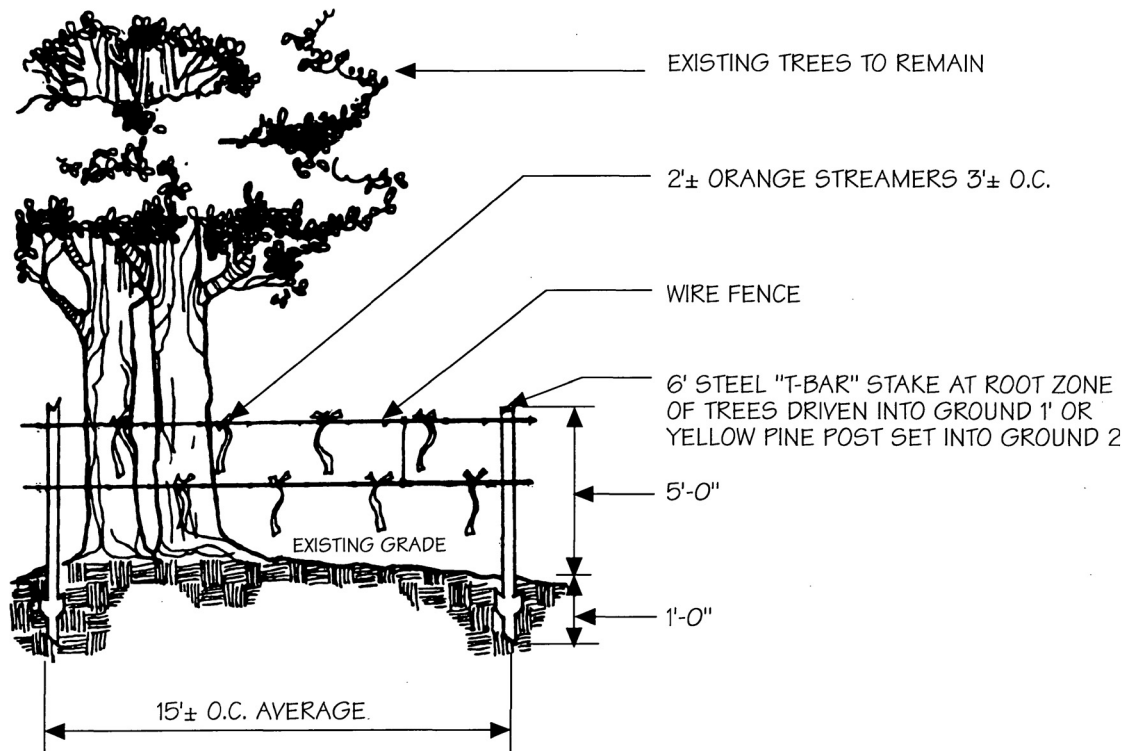

Notes:

1. Wire fence for forest protection device only.
2. Boundaries of Retention Area will be established as part of the Forest Conservation Plan review process.
3. Stake and flag boundaries of Retention Area prior to installing device.
4. Avoid root damage when placing anchor posts.
5. Securely attach wire to posts.
6. Maintain device throughout construction.
7. Protection signs are also required, see [Figures E-1](#) and [E-2](#).
8. Locate fence at the limit of disturbance (LOD).

Source: Adapted from Steve Clark & Associates/ACRT, Inc. and Prince George's County, Maryland Woodland Conservation Manual

**Figure E-5:
Snow Fence**

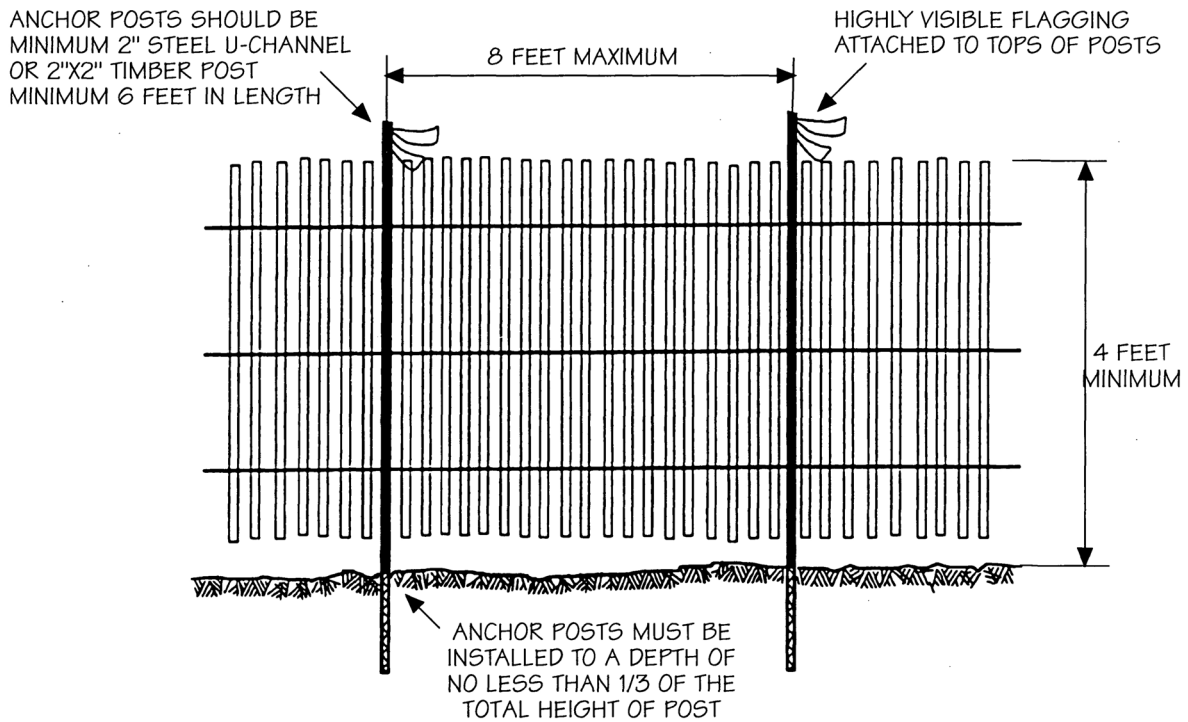

Notes:

1. Snow fence for forest protection device only.
2. Boundaries of Retention Area will be established as part of the Forest Conservation Plan review process.
3. Stake and flag boundaries of Retention Area prior to installing device.
4. Avoid root damage when placing anchor posts.
5. Securely attach snow fence to posts.
6. Maintain device throughout construction.
7. Protection signs are also required, see [Figures E-1](#) and [E-2](#).
8. Locate fence outside the Critical Root Zone.

Source: Adapted from Prince George's County, Maryland: Woodland Conservation Manual

**Figure E-6:
Silt Fence and Tree Protection**

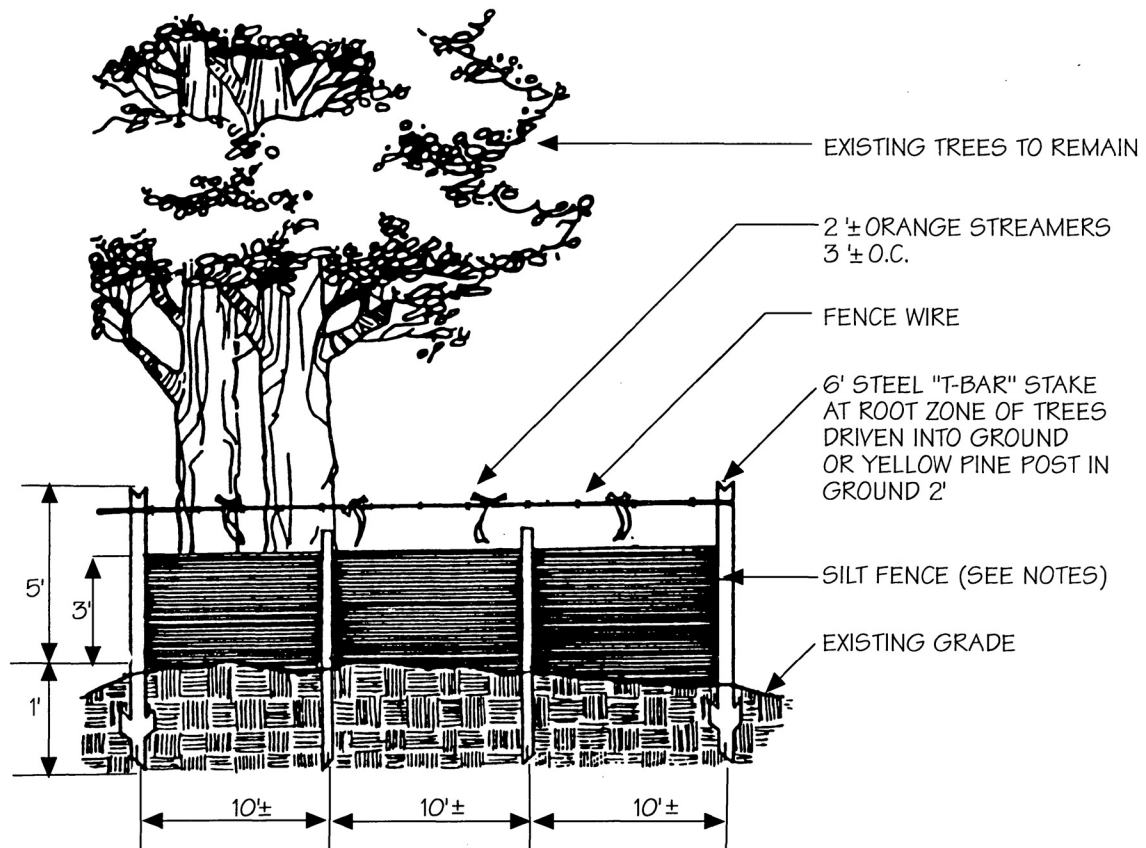

Notes:

1. Silt fence to be heeled into the soil.
2. Boundaries of Retention Area will be established as part of the Forest Conservation Plan review process.
3. Stake and flag boundaries of Retention Area prior to installing device.
4. Avoid root damage when placing anchor posts.
5. Maintain device throughout construction.
6. Protection signs are also required, see [Figures E-1](#) and [E-2](#).
7. Locate fence outside the Critical Root Zone.
8. Install tree protection fence at the limit of disturbance (LOD).

Source: Adapted from Steve Clark & Associates/ACRT, Inc.

**Figure E-7:
Earth Dike and Swale Combination Device**

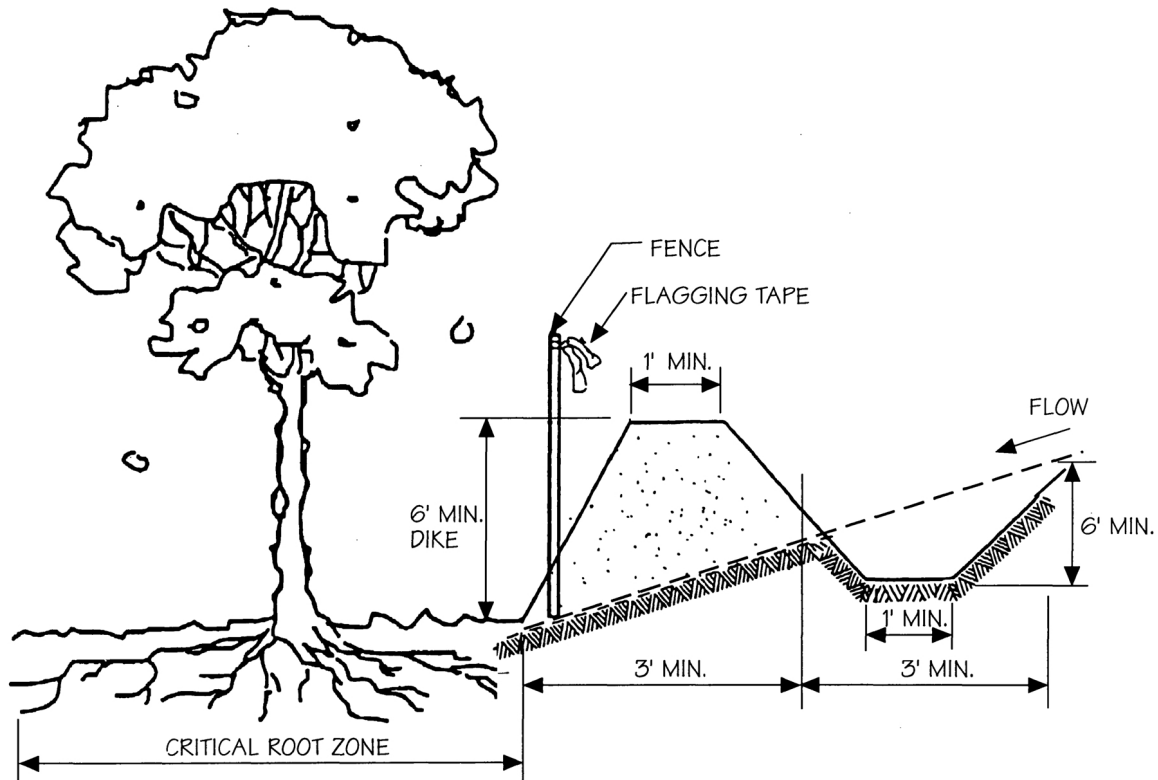

Notes:

1. Combine sediment control and forest protection device.
2. Boundaries of Retention Area will be established as part of the Forest Conservation Plan review process.
3. Stake boundaries of Retention Area prior to installing protection device.
4. Avoid root damage.
5. Locate toe of slope outside Critical Root Zone.
6. Equipment is prohibited within Critical Root Zone of Retention Area; place dike accordingly.
7. All standard maintenance for earth dikes and swales apply to these details.
8. All standard reclamation practices for earth dikes and swales shall apply to these details.

Source: Adapted from Prince George's County, Maryland: Woodland Conservation Manual

**Figure E-8:
 Field Edge Determination**

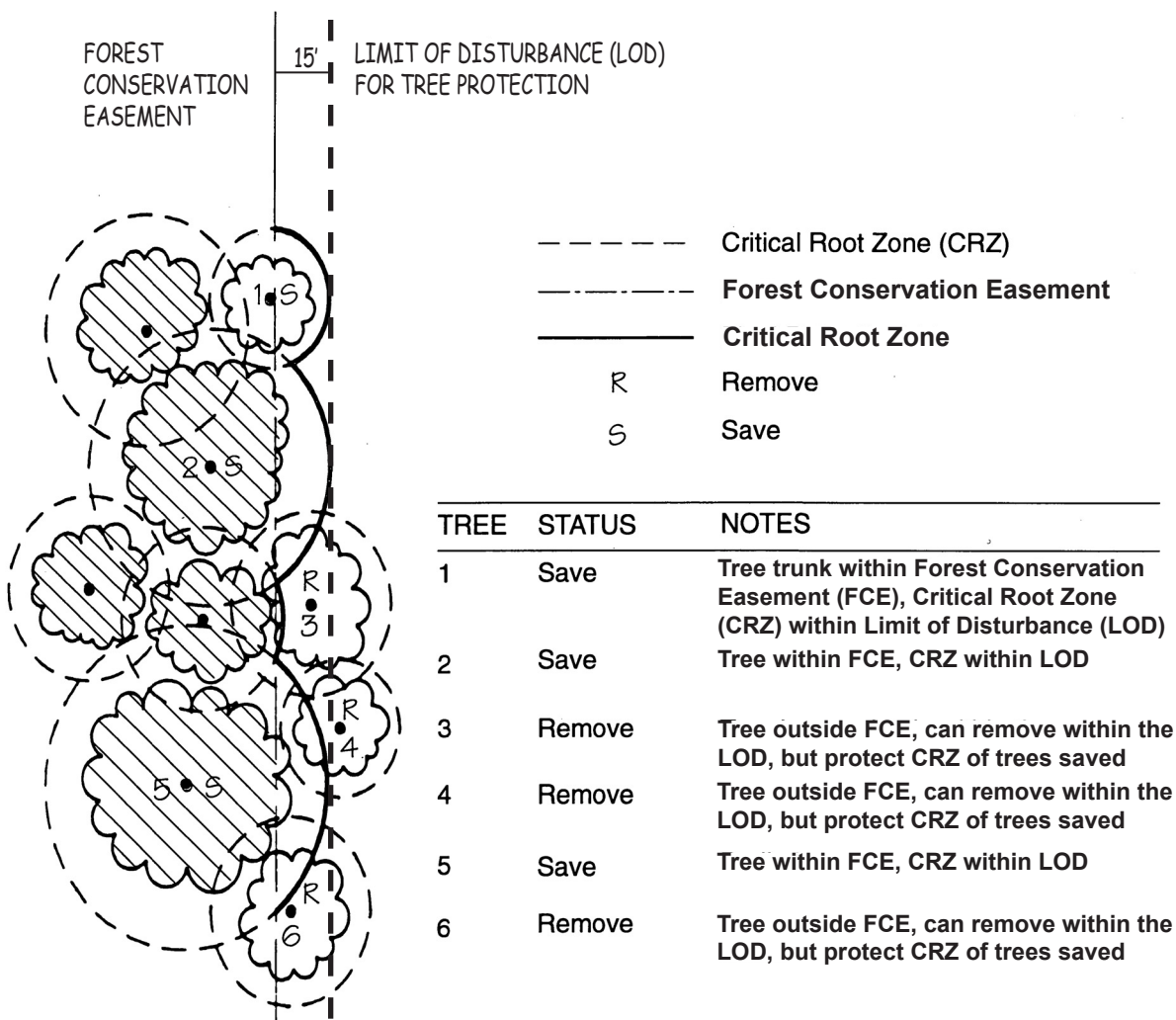

Notes:

1. The limit of disturbance (LOD), which is set back 15' from the Forest Conservation Easement (FCE), should ensure protection of the canopy and Critical Root Zone of trees at the edge of the FCE.
2. Staking the LOD in the field may require tree-by-tree decisions. The above example demonstrates the use of Critical Root Zone, but tree health and tree species must also be considered when laying out a final LOD.
3. For specimen trees, the LOD is defined as a circle around the tree with a radius of 1.5 feet for each 1.0 inch of DBH, or 15 feet from the FCE, whichever is greater.

Source: Prince George's County, Maryland: Woodland Conservation Manual

**Figure E-9:
Root Pruning**

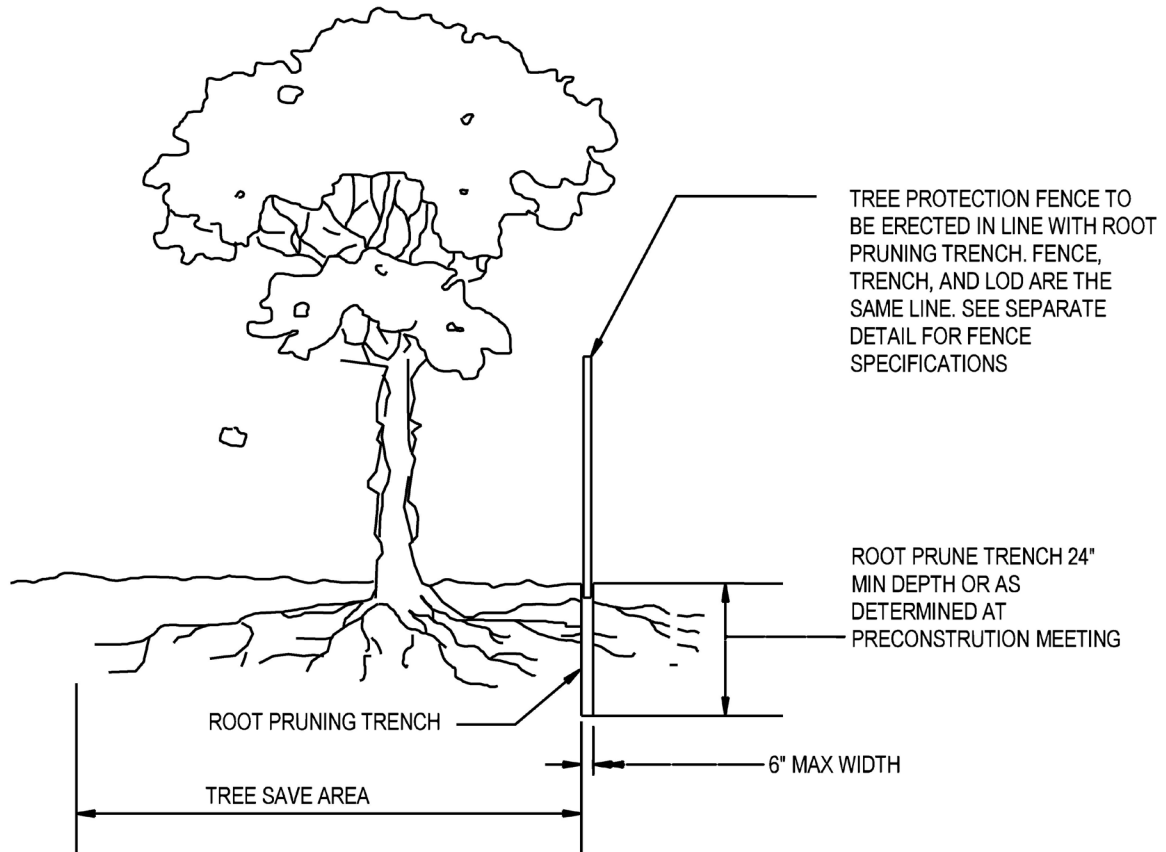

Notes:

1. Retention areas to be established as part of the Forest Conservation Plan review process.
2. Stake, flag and/or fence boundaries of Retention Areas prior to trenching.
3. Exact location of trench to be identified on site.
4. Immediately backfill trench with excavated soil or replace with organic soil.
5. Cut roots cleanly using vibratory knife or other acceptable equipment.

Source: Adapted from Steve Clark & Associates/ACRT, Inc. and State Forest Conservation Technical Manual 1991

**Figure E-10:
 Crown Reduction and Tree Pruning**

Pruning a Branch

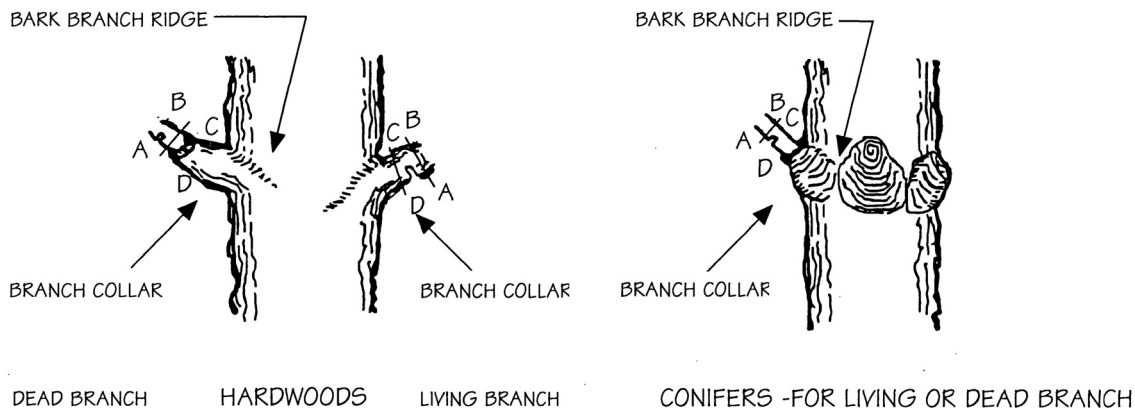

Notes:

1. Remove branch weight by undercutting at A and remove limb by cutting through at AB.
2. Remove stub at CD (line between branch bark ridge and outer edge of branch collar).
3. If D is difficult to find on hardwoods, angle of CD to trunk should be reflective angle of the bark branch ridge to the trunk.
4. Only prune at specified times.
5. Remove no more than 30% of crown at one time.

Pruning a Leader to Reduce Size

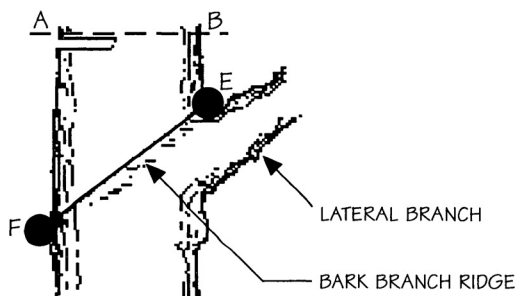

Notes:

1. Remove top weight by undercutting at A and remove limb by cutting through AB.
2. Remove stub at E / F parallel to the bark branch ridge.
3. Only prune at specified times.
4. Remove no more than 30% of crown at one time.
5. Diameter of lateral branch should be no less than 30% of the diameter of the leader.

Source: Fairfax County, Virginia: Vegetation Preservation & Planting, January 1986

**Figure E-11:
 Tree Well and Aeration System**

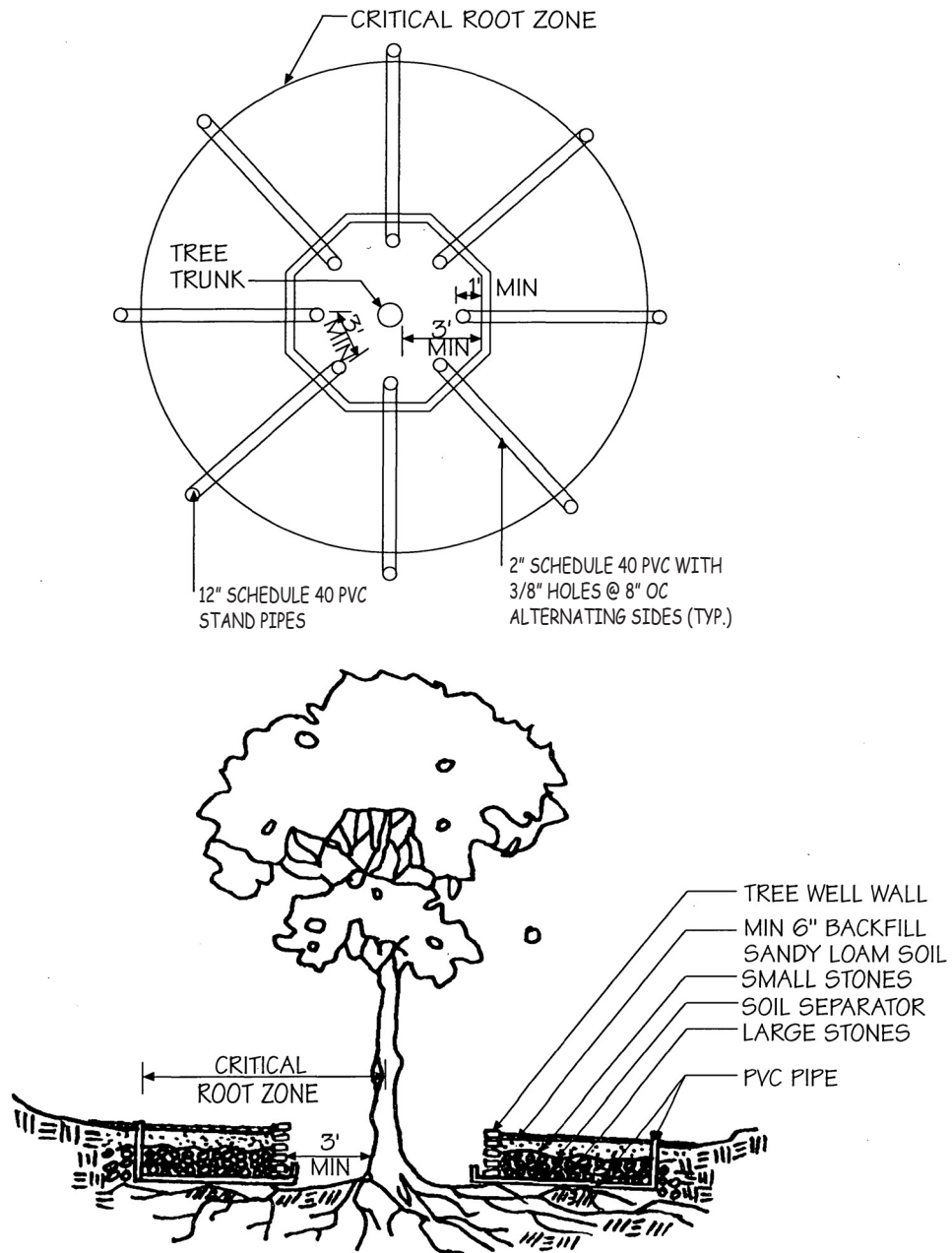

Notes:

1. Locate well wall no closer than 3 feet from tree trunk.
2. Extend drainage pipe layout beyond the Critical Root Zone.
3. Cap vertical pipes with a perforated flat cap with 4-3/8 inch holes per cap.
4. Locate radiating spokes on 3 foot centers at the well wall.

Source: University of Maryland, College Park

**Figure E-12:
Retaining Walls**

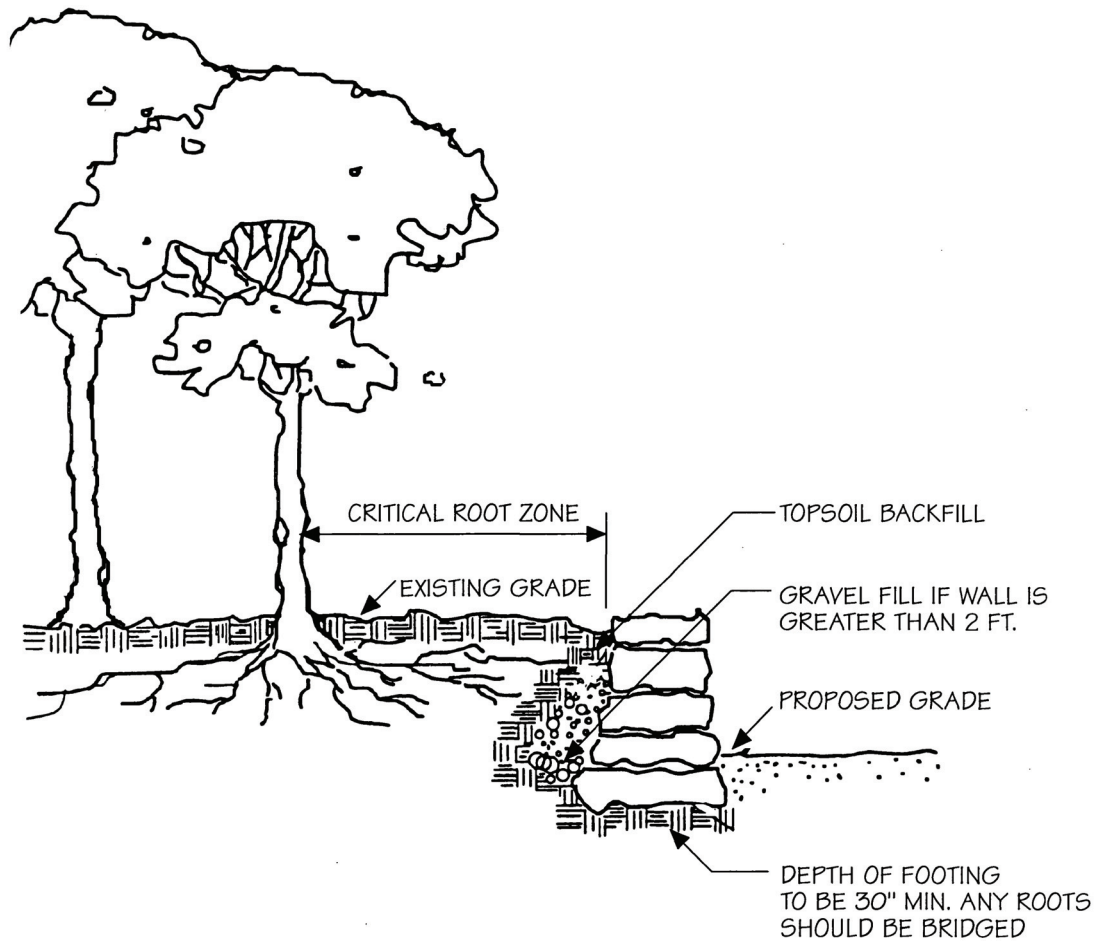

Notes:

1. Construct wall outside the Critical Root Zone.
2. Use extreme care to protect existing roots while constructing retaining wall, including anchoring system, if required.
3. If tree roots must be disturbed, prune roots per [Figure E-8](#).

Source: Fairfax County, Virginia: Vegetation Preservation & Planting, January 1986

**Figure E-13:
Sidewalk above Critical Root Zone**

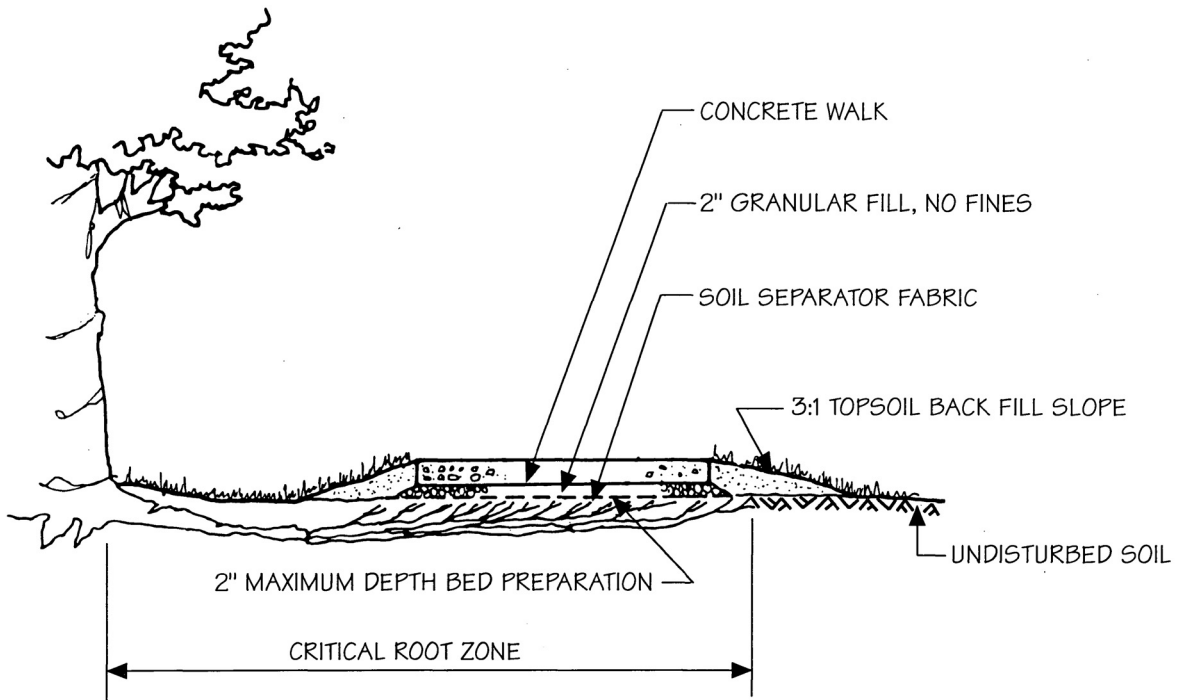

Notes:

1. Do not exceed a depth of 2 inches for bed preparation.
2. Granular fill should contain no fines.
3. Minimize width of sidewalk as allowed by code.
4. Take extreme care of existing trees' Critical Root Zone during construction.

Source: Adapted from Steve Clark & Associates/ACRT, Inc.

**Figure E-14:
 Aeration for Paving above Critical Root Zone**

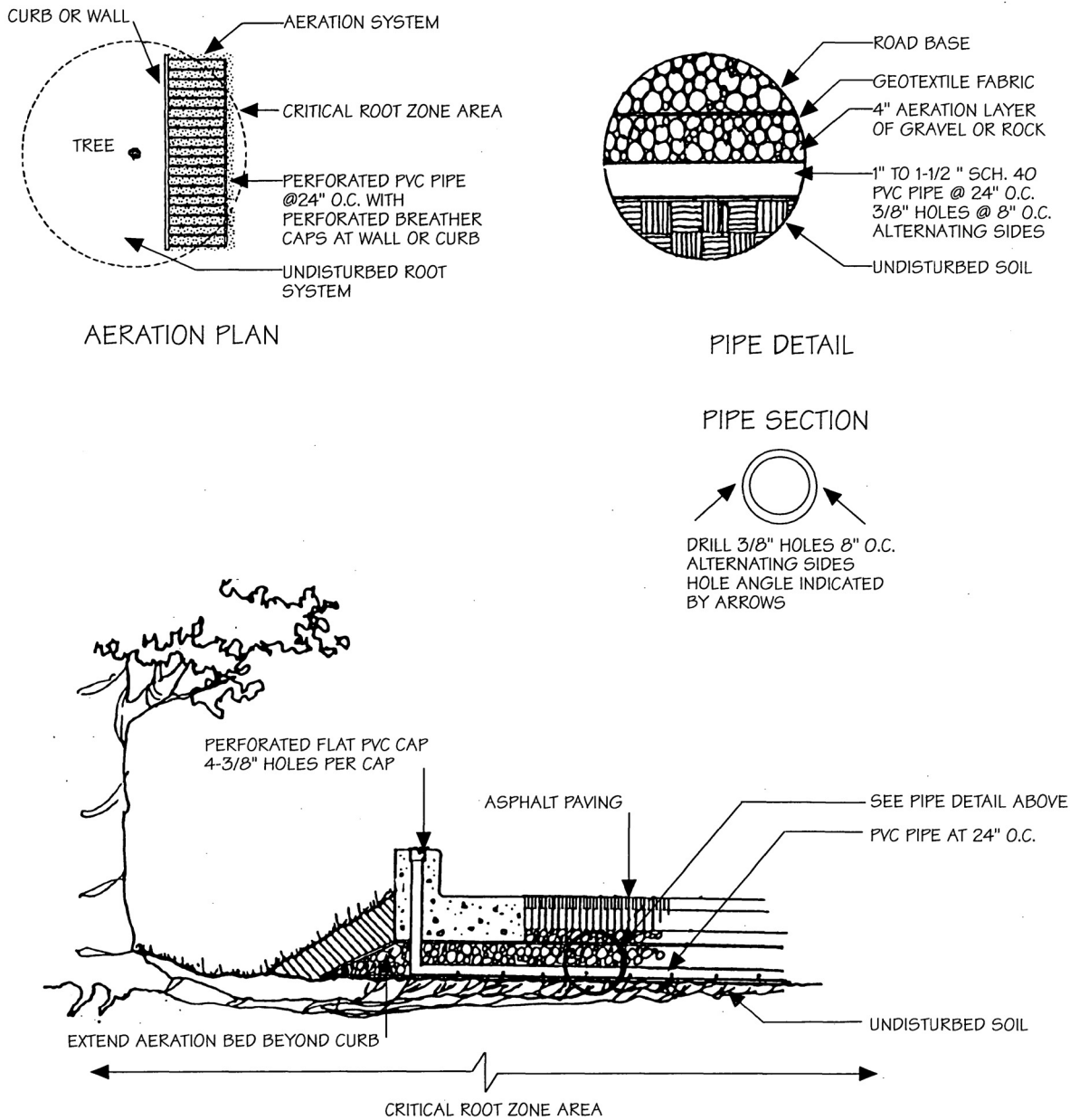

Notes:

1. Do not exceed a depth of 2 inches for bed preparation.
2. Cap vertical pipe with a perforated cap with 4-3/8 inch holes per cap.
3. Gravel or rock should contain no fines.
4. Can also be used when Critical Root Zone is covered by fill instead of asphalt.

Source: Adapted from Steve Clark & Associates/ACRT, Inc.

**Figure E-15:
Pier Wall Supports over Critical Root Zone**

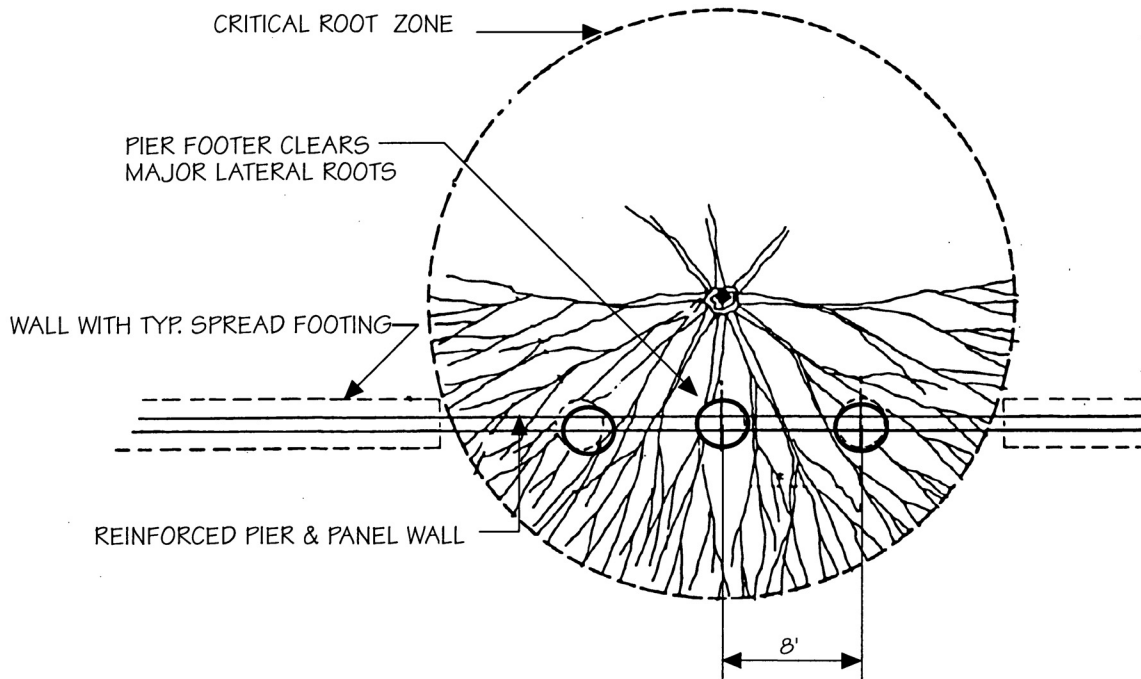

Notes:

1. Minimize area of disturbance.
2. Take care to avoid major lateral roots.
3. Cut roots cleanly using a vibratory knife or other similar equipment.

Source: Adapted from Steve Clark & Associates/ACRT, Inc.

**Figure E-16:
Tunneling through Critical Root Zone**

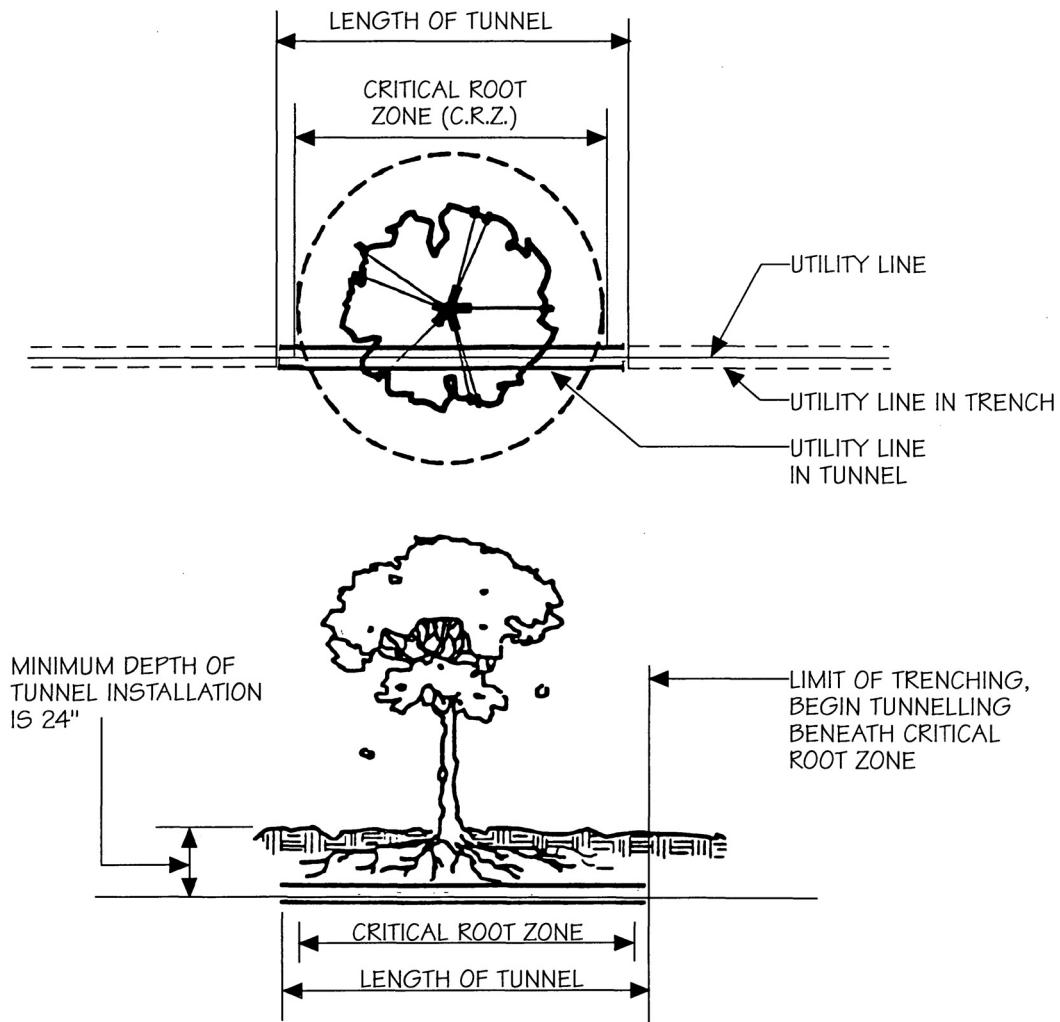

Notes:

1. Locate tunnel a minimum depth of 24 inches under Critical Root Zone.
2. When tunneling, aim for the trunk of the tree.
3. Tunnel through the Critical Root Zone, resume trenching of utilities beyond the Critical Root Zone.

Source: Adapted from Fairfax County, Virginia: Vegetation Preservation and Planting, January 1986

**Figure E-17:
Tree Banks for Transplanted and Bare Root Trees**

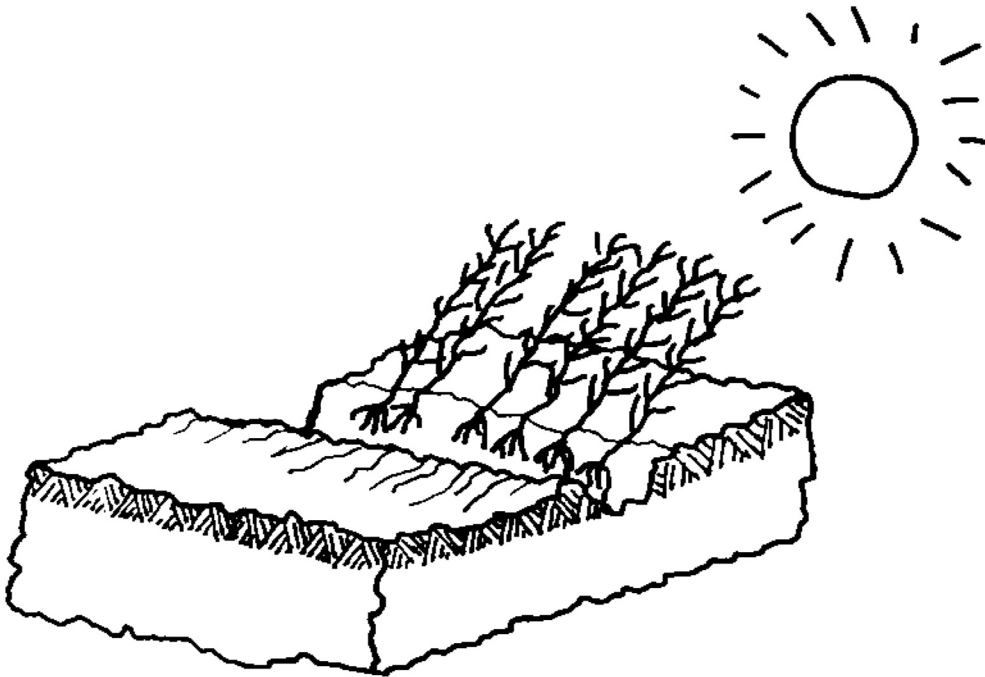

Notes:

1. Bank-in bare root trees when they must be left unplanted for longer than 24 hours.
2. Place trees in an east-west trench with the tops of the trees pointing toward the afternoon sun. Work moist soil around the roots to cover them and minimize air pockets. Pointing the tree tops toward the afternoon sun exposes the least surface to the sun so the buds will be less likely to begin growth.

Source: Adapted from State Forest Conservation Technical Manual, 1991

**Figure E-18:
Plant Installation**

Undisturbed Soil

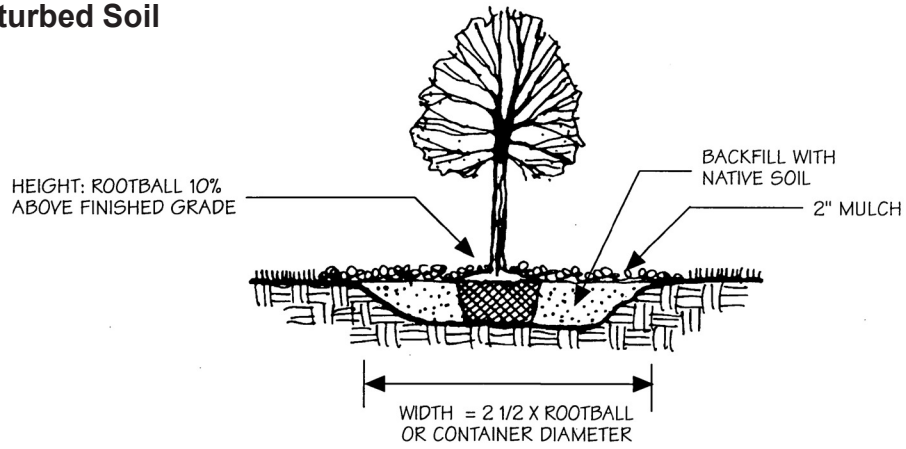

Disturbed Soil

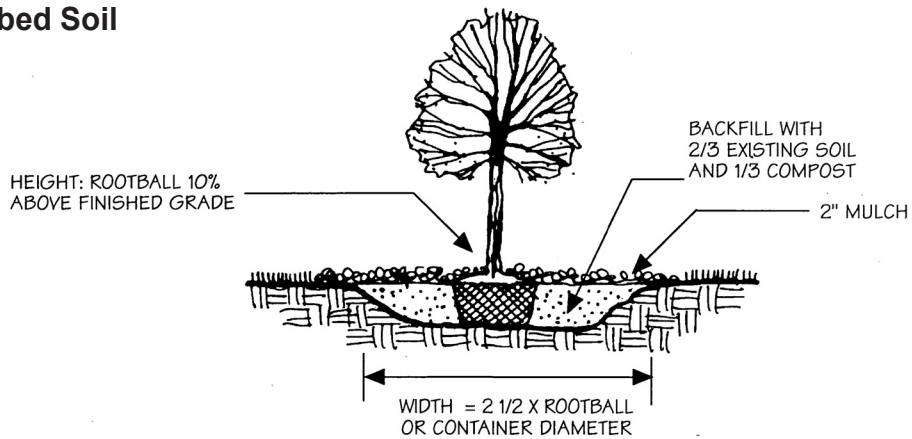

Planting on Slope

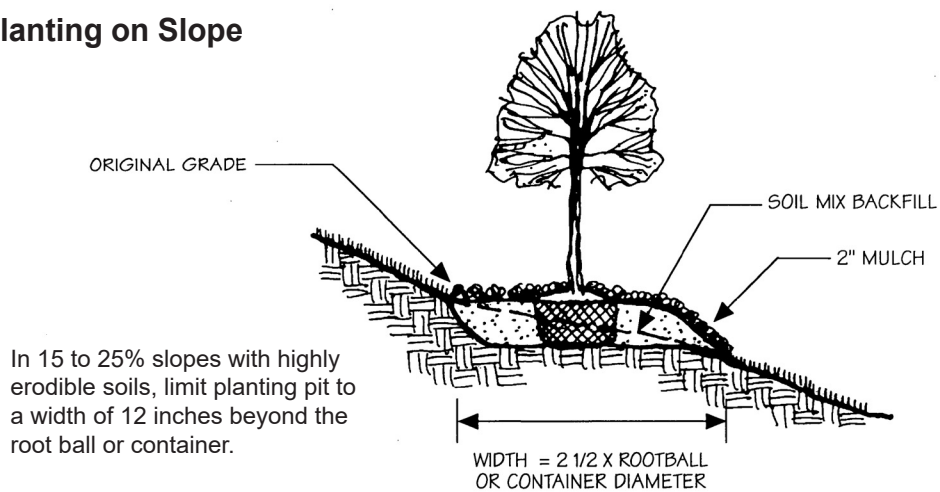

Source: Adapted from State Forest Conservation Technical Manual, 1991

Figure E-19: Seedling and Whip Planting Techniques — Planting

Heeling-in



1. DIG V-SHAPED TRENCH
IN MOIST SHADY PLACE



2. BREAK BUNDLES AND
SPREAD OUT EVENLY



3. FILL IN LOOSE SOIL AND
WATER WELL



4. COMPLETE FILLING IN SOIL
AND FIRM WITH FEET

Notes:

1. Heel-in bare root seedlings and whip stock when left unplanted for more than 24 hours.

Planting with a Mattock

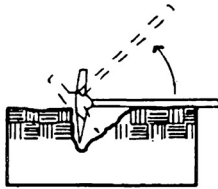

1. Insert mattock; lift handle
and pull



2. Place seedling along straight side
at correct depth.



3. Fill in and pack soil to
bottom of roots.



5. Firm around seedling with feet.



4. Finish filling in soil and firm with heel.

Source: Adapted from State Forest Conservation Technical Manual, 1991

Figure E-19: Seedling and Whip Planting Techniques — Planting (continued)

Planting with a Dibble Bar

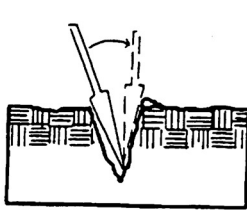

1. INSERT DIBBLE AT ANGLE SHOWN ABOVE AND PUSH FORWARD TO UPRIGHT POSITION



2. REMOVE DIBBLE AND PLACE SEEDLING AT CORRECT DEPTH

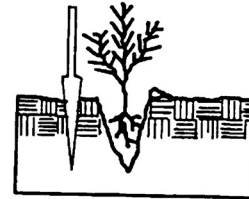

3. INSERT DIBBLE 2 INCHES TOWARD PLANTER FROM SEEDLING

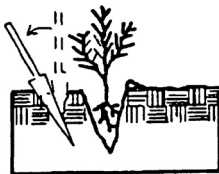

4. PULL HANDLE OF DIBBLE TOWARD PLANTER FIRING SOIL AT BOTTOM OF ROOTS



5. PUSH HANDLE OF DIBBLE FORWARD FROM PLANTER FIRING SOIL AT TOP OF ROOTS

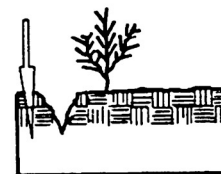

6. INSERT DIBBLE 2 INCHES FROM SEEDLING

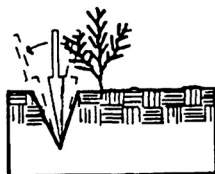

7. PULL FORWARD THEN PULL BACKWARD FILLING HOLE



8. FILL LAST HOLE BY STAMPING WITH HEEL

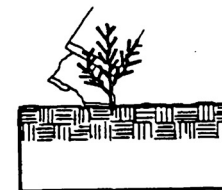

9. FIRM SOIL AROUND SEEDLING WITH FEET

Source: Adapted from Duryea & Dougherty, Forest Regeneration Manual, Kluwer Academic Publishers, Boston, 1991 and State Forest Conservation Technical Manual, 1991

Figure E-20: Seedling and Whip Planting Techniques — Other Considerations

Correct and Incorrect Planting Depth

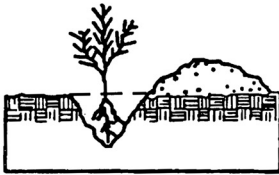

Correct
AT SAME DEPTH OR
1/2 DEEPER THAN
SEEDLING WAS GROWN
IN NURSERY

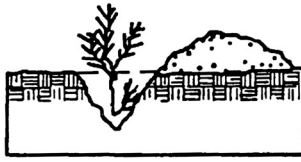

Incorrect
TOO DEEP AND ROOT
BENT

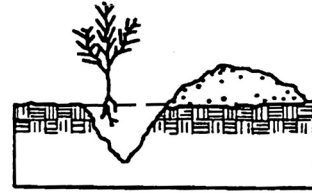

Incorrect
TOO SHALLOW AND ROOTS
EXPOSED

Keep Plants Wet while Handling in the Field

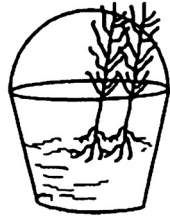

Correct
IN BUCKET WITH SUFFICIENT
WATER TO COVER ROOTS



Incorrect
IN HAND:
ROOTS DRY OUT

Notes:

1. Keep the roots of bare root seedlings and whip stock in water buckets until planted to avoid roots drying out.

Mulching New Plantings



Notes:

1. Mulching newly planted seedlings helps the soil retain moisture and protects the seedlings from compaction and stem injuries.

Source: Adapted from State Forest Conservation Technical Manual, 1991

Figure E-21: Tree Staking and Guying

Typical Tree Staking Detail

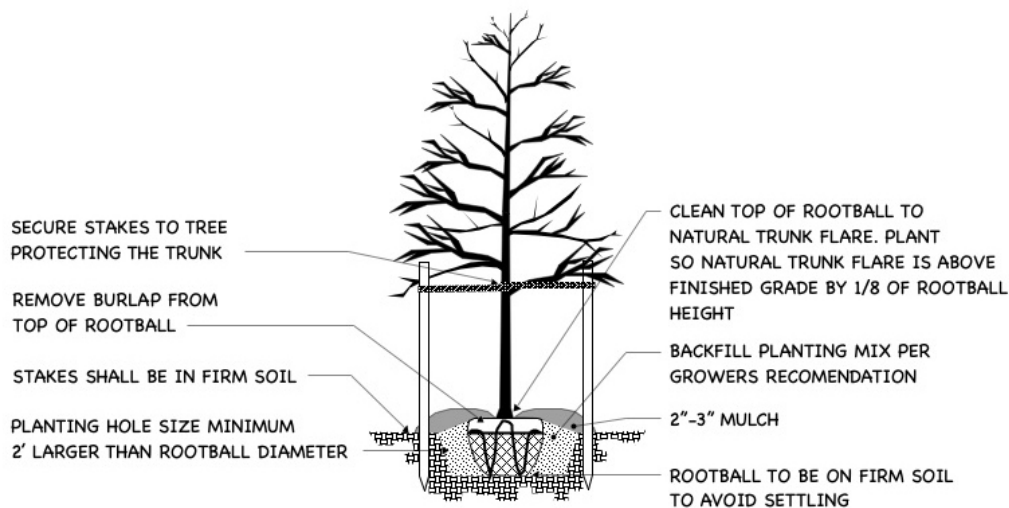

Typical Tree Guying Detail

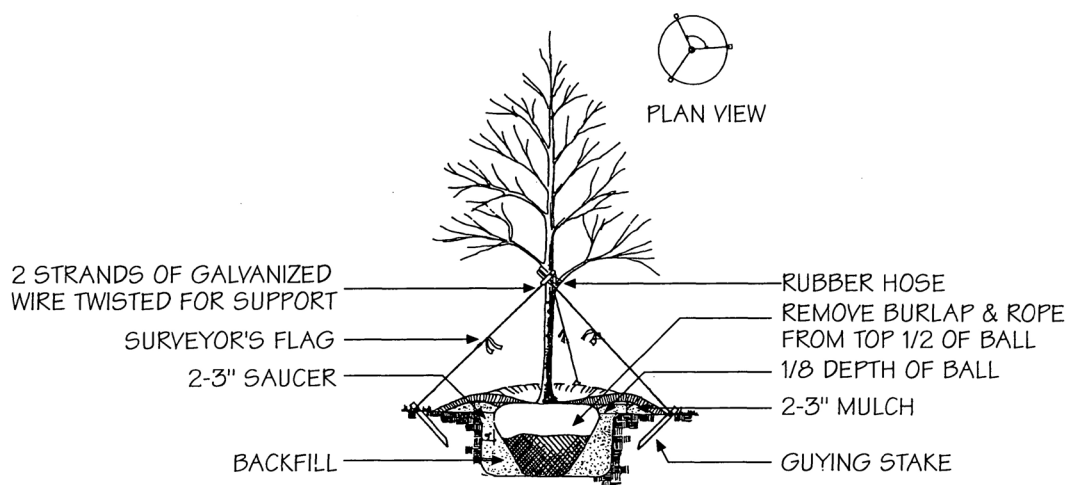

Notes:

1. Remove all tree staking and guying materials from the tree after the first growing season.
2. Tree staking ties can include galvanised, twisted wire with hose sections against the trunk, tie webbing, poly chain-lock or other suitable material.
3. Guying, rather than staking, is appropriate for large calliper trees (3" or larger), large rootballs (42" diameter or larger), or when necessary according to site conditions, such as, exposed and windy sites or sites with an excess fill condition.

Source: Adapted from State Forest Conservation Technical Manual, 1991

**Figure E-22:
Tree Shelters**

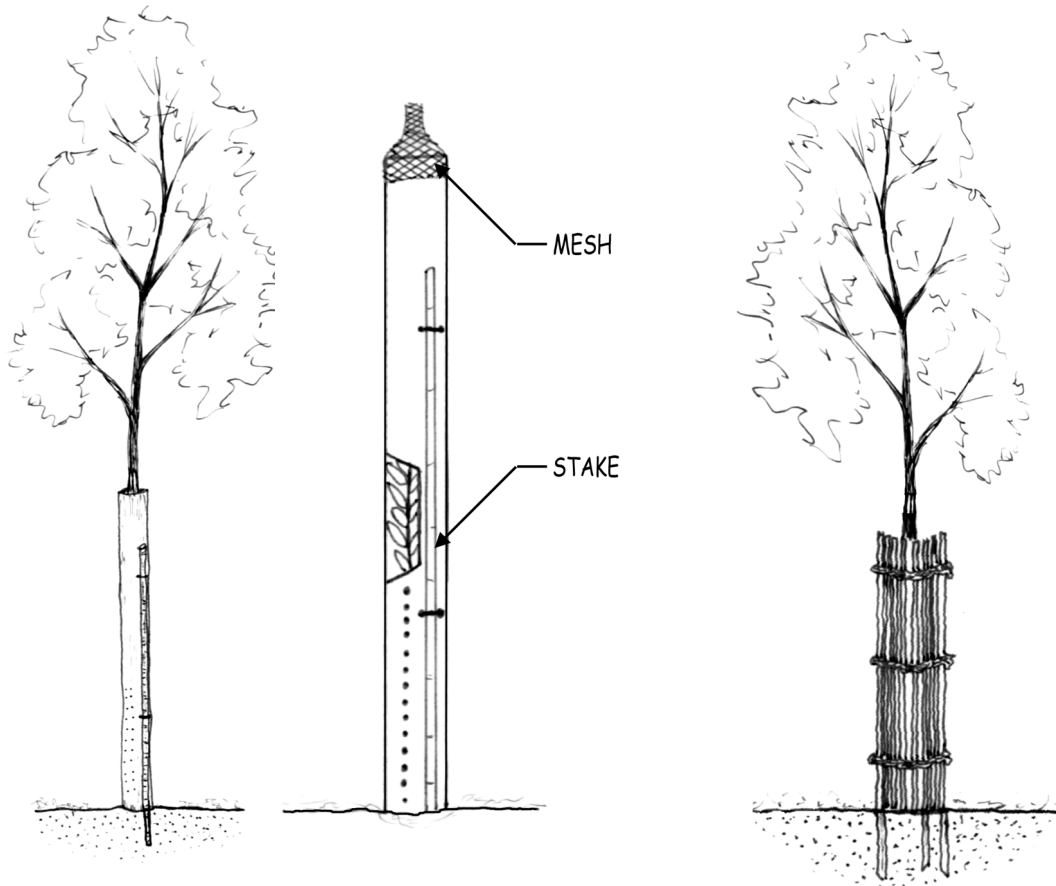

Plastic Tree Shelter and Detail

Biodegradable Tree Shelter

Notes:

1. Shelters are available from various manufacturers such as Tubex, Blue-X, Tree-Pro, Protex, Mirical Tube, Mesh Guard, EcoDepot and others.
2. Shelters shall be installed per manufacturer's specifications.
3. Remove tree shelters per the recommendation by the Department of Recreation and Parks.
4. Biodegradable tree shelters, such as EcoDepot, Bio Bark and others, do not need to be removed.

Source: Howard County Department of Planning and Zoning

**Figure E-23:
Plastic Mesh Tree Shelters**

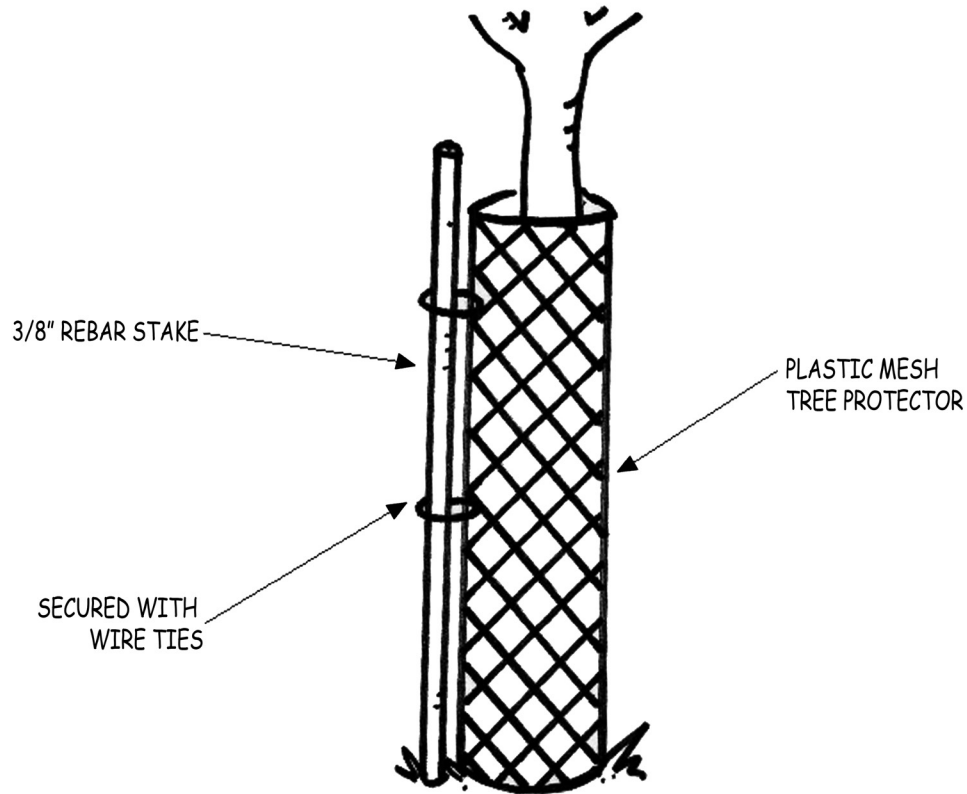

Notes:

1. Plastic mesh tree shelter is flexible, easy to install, reusable and UV treated.
2. Shelter is 4" diameter by 48" high.
3. Mesh is 3/4" by 3/4" with each strand about 1/8" by 1/8" by 1/8."
4. Secure shelter to ground with rebar 3/8" diameter by 5' long. Drive rebar into the ground 12" to 18."
5. Secure shelter to rebar with 2 to 3 wire ties.
6. Mesh tree shelters may also be constructed of wire mesh or fencing with dimensions and installation methods as described above.
7. Remove tree shelters per the recommendation by the Department of Recreation and Parks.

Source: Howard County Department of Recreation and Parks

APPENDIX F: FEE-IN-LIEU REQUEST FORM

Howard County Forest Conservation Program

FEE-IN-LIEU REQUEST

File Election Tax Lot or
Number District Map Parcel

Name(s)
Location

I (We) _____, proposing an activity on the above property requiring conformance to Section 16.1200 of the Howard County Code (Forest Conservation Program) and such activity resulting in reforestation or afforestation obligations in accordance with Sections 16.1206 or 16.1207 of the Code hereby request such obligations be fulfilled by payment in lieu of such planting in accordance with the fees set by the County Council.

The total obligations for reforestation or afforestation, based on the attached plan and worksheets, equal _____ sq. ft.

Payment of a fee-in-lieu is requested because reforestation or afforestation requirements cannot reasonably be accomplished on-site under the options available in the Forest Conservation Manual due to the following conditions:

In addition, the reforestation or afforestation requirements cannot be fulfilled at an off-site location(s) including a mitigation bank(s), because: (be sure to include a listing of off-site locations and banks that were considered and why they are not viable)

It is my (our) understanding that, if granted, this request for fee-in-lieu payment will require payment of \$ _____ to the Howard County Forest Conservation Fund and that such payment shall be required prior to approval of the proposed activity(ies) creating this Forest Conservation Program obligation. It is also my (our) understanding that this payment only

applies to the activities and obligations described in the attached plan and worksheets and that any additional or future activities not described as part of this request may be subject to additional Forest Conservation Program requirements.

I (We) declare that this declaration, including any accompanying forms and statements, has been examined by me (us) and the information contained herein, to the best of my (our) knowledge, information and belief, is true, correct and complete.

Signature(s)

Date

APPENDIX G: REFERENCES AND RESOURCES

Publications

American Nursery and Landscape Association. 2004. American Standard for Nursery Stock, Washington, D.C. (American National Standards Institute, Inc. ANSI Z60.1-2004)

Brown, Russel G. and Brown, Melvin L. Herbaceous Plants of Maryland. Port City Press. Baltimore, MD. 1984.

Brown, Russel G. and Brown, Melvin L. Woody Plants of Maryland. Port City Press. Baltimore, MD. 1972.

Brush, G.S., C. Lenk, and J. Smith. 1980. The natural forests of Maryland: an explanation of the vegetation map of Maryland (with 1:250,000 map). Ecological Monographs 50:77-92.

Maryland Department of Natural Resources. 2005. Riparian Forest Buffer Design and Maintenance. Maryland Department of Natural Resources, Annapolis, MD.

Maryland Department of Natural Resources. 1997. State Forest Conservation Technical Manual.

Maryland Department of Natural Resources, Annapolis, MD.

Swearingen, J., B. Slattery, K. Reshetiloff, and S. Zwicker. 2010. Plant Invaders of Mid-Atlantic Natural Areas, 4th ed. National Park Service and U.S. Fish & Wildlife Service, Washington, D.C.

U. S. Department of Agriculture, Natural Resources Conservation Service in Cooperation with Maryland Agricultural Experiment Station, Maryland Department of Agriculture, Howard County Board of Commissioners, and Howard County Soil Conservation District. Soil Survey of Howard County, Maryland. Issued May 2008.

Slattery, Britt E., Kathryn Reshetiloff, and Susan M. Zwicker. 2003. Native Plants for Wildlife Habitat and Conservation Landscaping: Chesapeake Bay Watershed. U.S. Fish and Wildlife Service, Chesapeake Bay Field Office, Annapolis, MD.

<https://www.fws.gov/Chesapeakebay/pdf/NativePlantsforWildlifeHabitatandConservationLandscaping.pdf> .

Organizations and Web Sites

American Nursery and Landscape Association <http://www.anla.org/>

Botanical Society of Washington <http://www.botsoc.org/>

Chesapeake Bay Native Plant Center <http://www.nativeplantcenter.net/>

ITIS: Integrated Taxonomic Information System, <http://www.itis.gov>

Center for Invasive Species and Ecosystem Health <https://www.invasive.org/index.htm>

Maryland Department of Agriculture, <https://mda.maryland.gov/Pages/default.aspx>

Maryland Department of Natural Resources, <https://dnr.maryland.gov/Pages/default.aspx>

Maryland Invasive Species Council, <http://www.mdinvasivesp.org>

Maryland Native Plant Society, <http://www.mdflora.org/>

Mid-Atlantic Exotic Pest Plant Council, <https://www.invasive.org/maweeds.cfm>

National Agricultural Pest Information System, <https://napis.ceris.purdue.edu/home>

National Invasive Species Council, <https://www.doi.gov/invasivespecies/>

The Nature Conservancy Wildland Invasive Species Program, <https://www.invasive.org/gist/>

U.S. Department of Agriculture, Animal and Plant Health Inspection Service, Plant Protection and Quarantine, <http://www.aphis.usda.gov/ppq/weeds/>

U.S. Department of Agriculture, Natural Resources Conservation Service, Soils, <http://soils.usda.gov/>

U.S. Fish and Wildlife Service, Invasive Species, <https://www.fws.gov/invasives/>

U.S. National Park Service, Invasive & Non-Native Species <https://www.nps.gov/subjects/invasive/index.htm>

APPENDIX H: FOREST INSPECTION GUIDANCE

The following checklists, forms and explanations are provided for guidance during the construction inspection, and construction completion process:

- H-1: Forest Inspection Checklist
- H-2: Reforestation Inspection / Completion Report
- H-3: Forest Inspection Survival Count Procedure

H-1: Forest Inspection Checklist

Project Name: _____
File Number: _____
Inspected By: _____
Inspection Date: _____
Site Location: _____

- _____ Pest or disease infestations
- _____ Inhibited/stunted growth Deer _____ Drought _____ Other _____
- _____ Binding or restriction due to stakes and ties
- _____ Broken, dead or diseased branches
- _____ Wilted, curled or distorted leaves or dried out buds
- _____ Leaf color abnormalities (spots, yellowing, or brown margins); early leaf drop
- _____ Cracks in bark from sunburn
- _____ Sucker growth at the base or on the sides of the tree's trunk
- _____ Holes or substances oozing from the trunk
- _____ Severe erosion, sunken holes in the root-ball area, or an inadequate watering basin that threatens the young trees water supply
- _____ Flooding or poor drainage
- _____ A layer of soot or particulate matter from air pollution
- _____ Invasive plant growth threatening viability of reforestation or afforestation plantings
- _____ Improper use or intrusions into forest conservation areas
- _____ Missing or damaged protective measures (fences, signs, etc.)
- _____ Unauthorized clearing or other removal of forest vegetation

Deer Management:

Repellant: Yes _____ No _____

Tampering: Yes _____ No _____

Effectiveness: _____

Replacement:

Quantity _____ Date _____

Comments: _____

Area #: _____

_____	Planted	_____	Total number of plots
_____	Counted	_____	Stocked plots
_____	Live	_____	Area stocked

Area #: _____

_____	Planted	_____	Total number of plots
_____	Counted	_____	Stocked plots
_____	Live	_____	Area stocked

Area #: _____

_____	Planted	_____	Total number of plots
_____	Counted	_____	Stocked plots
_____	Live	_____	Area stocked

Area #: _____

_____	Planted	_____	Total number of plots
_____	Counted	_____	Stocked plots
_____	Live	_____	Area stocked

H-2: Reforestation Inspection / Completion Report

Project Name: _____

File Number: _____

Acreage: _____

Site Location: _____

Date planted: _____

Plan prepared by: _____

Inspection conducted by: _____

Inspection date: _____

Comments: _____

First Growing Season Inspection (90% or over):

Date: _____ Percent living: _____ %

Replant date: _____ Replanted to: _____ %

Second Growing Season Inspection (75% or over):

Date: _____ Percent living: _____ %

Replant date: _____ Replanted to: _____ %

Third Growing Season Inspection, (75% or over):

Date: _____ Percent living: _____ %

Replant date: _____ Replanted to: _____ %

Final Inspection: (75% or over):

Date: _____ Percent living: _____ %

H-3: Forest Inspection Survival Count Procedure

Department of Recreation and Parks Procedures

Survival counts are a method for estimating survival rates. Counts use a sampling method based on percentage of area supporting acceptable trees. For properties where trees are planted at a ratio of 100 trees per acres or for small sites, the Department of Recreation and Parks (DRP) counts all trees on site. Where trees are planted at higher ratios or for large sites, DRP generally uses a sampling procedure in their inspection of Forest Conservation plantings. The procedures described below follow widely accepted methods to tally regeneration and may be used by the County when it conducts final inspections.

In general, for this sampling method, a 6-foot radius plot is installed every 33 feet or $\frac{1}{2}$ chain. At this rate, between 8 and 10 percent of the area is sampled. The distance between plots, as well as the distance between lines, should be 33 feet. A 6-foot radius plot is equivalent to $\frac{1}{385}$ acre. At a planting rate of 300 trees per acre, each 6-foot radius plot should contain at least one acceptable tree. Acceptable trees are woody species, native to the Mid Atlantic region, of any size, with at least two normal-sized leaves, and that have shed the cotyledons. Survival tallies should be implemented after late May and before mid September.

To conduct a survival count, use the following procedures:

- To locate the first plot, start at any corner of the planting site, proceed in a cardinal direction for $\frac{1}{2}$ the distance between plots, or 16 feet. Then, turn 90 degrees and proceed for $\frac{1}{2}$ the distance between lines, or 16 feet. This is plot center. To locate additional plots, continue along the same line for 33 feet.
- Follow each line, installing plots, to the opposite edge of the planting site. Note the distance from the last plot, turn 90 degrees and proceed for 33 feet to the next line. Turn an additional 90 degrees and continue for the remaining distance to the next plot. Any distance remaining after the last plot on the first line is included in the distance to the first plot on the second line. For example, if the last plot is 10 feet from the edge of the planting site, turn 90 degrees proceed for 33 feet, turn 90 degrees and proceed for the remaining 23 feet. Then continue along the same bearing to locate the next plot.
- At each plot, use a tally sheet to record the species of the dominant, or most vigorous, tree by height class. Height is classified into two categories, those plants with at least one main lead that is above the height capable of being browsed by deer, and those plants within reach of being browsed by deer.
- Determine the percent of plots containing at least one acceptable tree by dividing the number of plots containing at least one acceptable tree or shrub by the total number of plots tallied. This is equivalent to the percentage of area supporting acceptable trees.

To determine replant requirements to meet the required survival count, use the following procedure:

When the survival rate has been determined, the number of plants needed to replant the site can be calculated. Multiply the percentage of area lacking acceptable trees by 300 plants per acre (or the required ratio based on the size material planted, see Figure 3-L). Multiply this by the number of acres of the site. For example, if a site is 3 acres in size and the first growing season inspection requires 90 percent survival, the following calculations should be used to

determine the number of replants: if 80 percent of the area, or 80 percent of the plots, contain acceptable plants, then the number of plants needed to replant is:

$$90\% - 80\% = 10\% \text{ or } 0.10$$
$$0.10 \times 300 \text{ plants/acre} \times 3 \text{ acres} = 90 \text{ plants}$$

As another example, if the second growing season inspection requires 75% survival, the following calculations should be used to determine the number of replants: if 68 percent of the area, or 68 percent of the plots, contain acceptable plants, then the number of plants needed to replant is:

$$75\% - 68\% = 7\% \text{ or } 0.07$$
$$0.07 \times 300 \text{ plants/acre} \times 3 \text{ acres} = 54 \text{ plants}$$

Given that the final inspection requires a 75 percent survival count, replanting at the end of the second growing season should exceed the minimum needed to account for potential plant mortality during the subsequent growing season.

Department of Natural Resources Procedure

The following method is based upon procedures recommended by the Department of Natural Resources in its forest conservation training programs for Qualified Professionals:

- Choose a center for a 1/20 acre circular plot.
- Measure out from the center 26' 3" in 4 to 8 compass directions. Flag the circle boundary.
- Count all trees within the 1/20 acre plot that are present.
- Calculate the number of trees per acre by multiplying the tree count by 20.
- Number of trees per acre= _____ trees.
- For two plots multiply # of trees times 10.
- For three plots multiply # of trees by 6.6.